

**Notes:**  
 1. All cables are to be minimally 8AWG THHN  
 2. TBB = Terminal Bus Bar

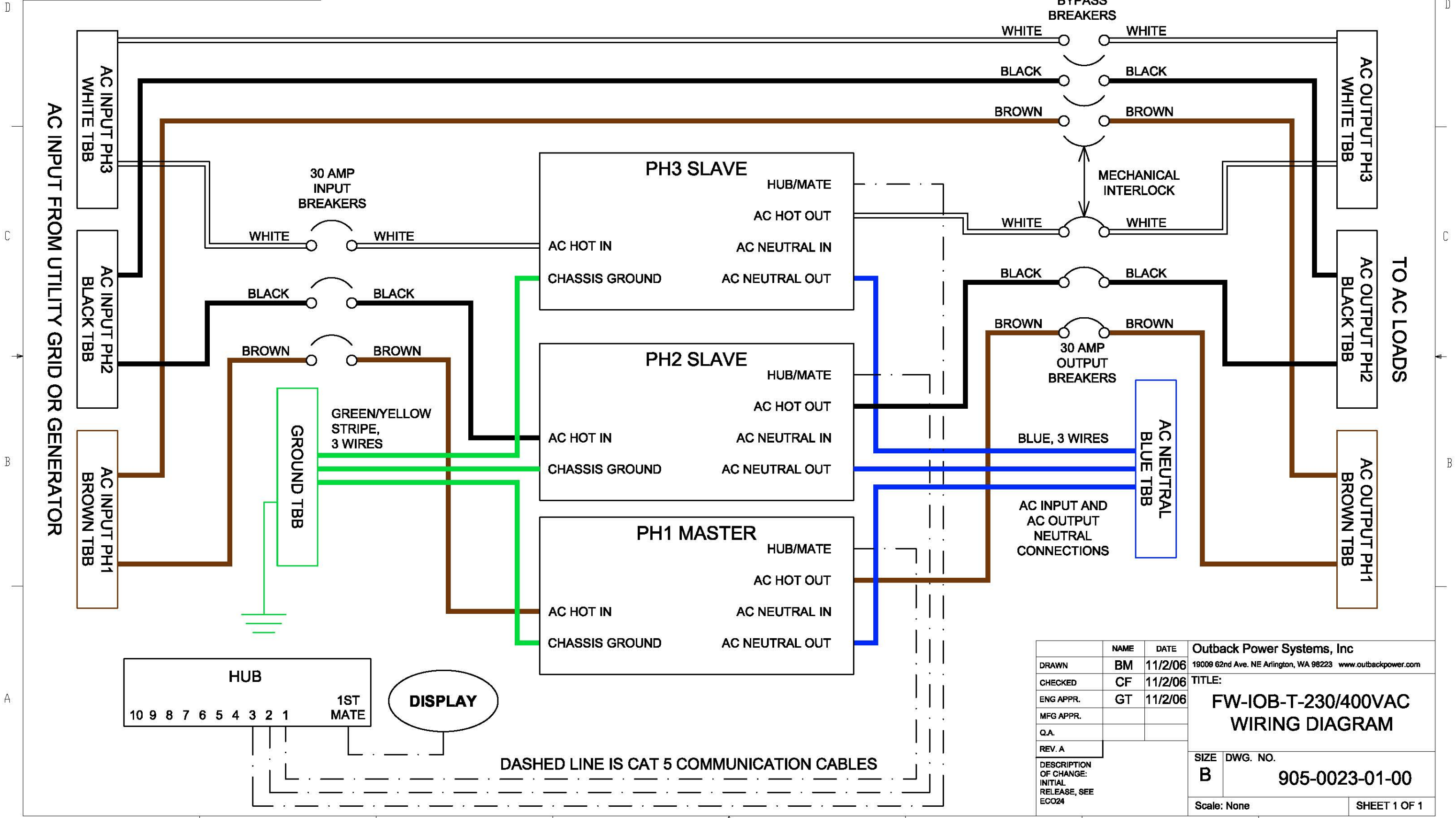

DASHED LINE IS CAT 5 COMMUNICATION CABLES

			Outback Power Systems, Inc 19009 62nd Ave. NE Arlington, WA 98223 www.outbackpower.com	
DRAWN	BM	11/2/06	TITLE:	
CHECKED	CF	11/2/06	FW-IOB-T-230/400VAC WIRING DIAGRAM	
ENG APPR.	GT	11/2/06	SIZE	DWG. NO.
MFG APPR.			B	905-0023-01-00
Q.A.			Scale: None	SHEET 1 OF 1
REV. A				
DESCRIPTION OF CHANGE: INITIAL RELEASE, SEE ECO24				