

ROTATING  
3DVIEW

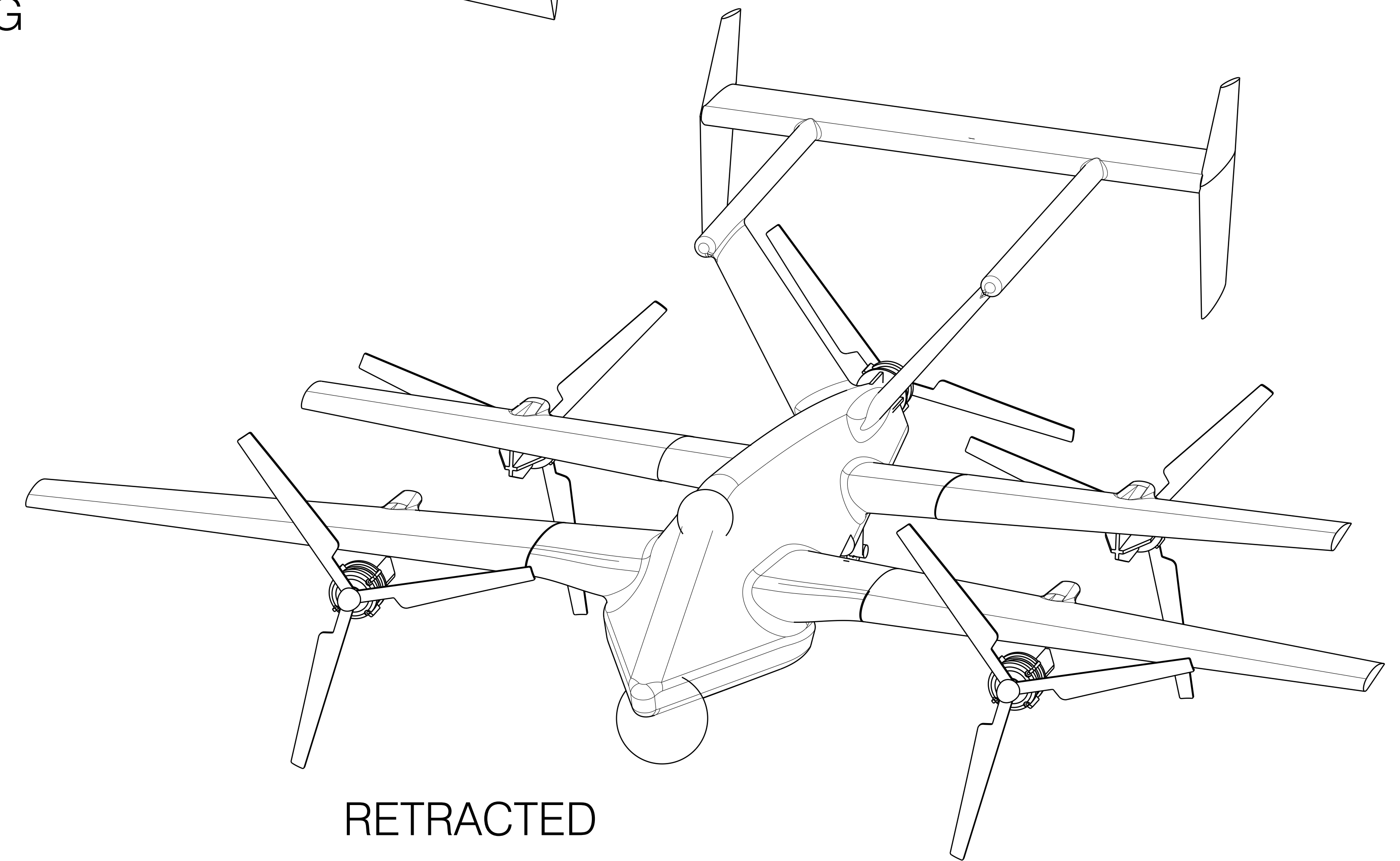

RETRACTED  
3DVIEW