



# Product Manual

High Voltage Hybrid Single Phase  
Residential Energy Storage Inverter



Available Models:

S6-EH1P3.8K-H-US

S6-EH1P5K-H-US

S6-EH1P7.6K-H-US

S6-EH1P10K-H-US

S6-EH1P11.4K-H-US

# Important Notes

---

- Product specifications are subject to change without notice. Every attempt has been made to make this document complete, accurate and up-to-date. Individuals reviewing this document and installers or service personnel are cautioned, however, that Solis reserves the right to make changes without notice and shall not be responsible for any damages, including indirect, incidental or consequential damages caused by reliance on the material presented including, but not limited to, omissions, typographical errors, arithmetical errors or listing errors in the material provided in this document.
- Solis accepts no liability for customers' failure to comply with the instructions for correct installation and will not be held responsible for upstream or downstream systems Solis equipment has supplied.
- The customer is fully liable for any modifications made to the system; therefore, any hardware or software modification, manipulation, or alteration not expressly approved by the manufacturer shall result in the immediate cancellation of the warranty.
- Given the countless possible system configurations and installation environments, it is essential to verify adherence to the following:
  - There is sufficient space suitable for housing the equipment.
  - Airborne noise produced depending on the environment.
  - Potential flammability hazards.
- Solis will not be held liable for defects or malfunctions arising from:
  - Improper use of the equipment.
  - Deterioration resulting from transportation or particular environmental conditions.
  - Performing maintenance incorrectly or not at all.
  - Tampering or unsafe repairs.
  - Use or installation by unqualified persons.
- This product contains lethal voltages and should be installed by qualified electrical or service personnel having experience with lethal voltages.

# Table of Contents

**1 Introduction**

**2 Safety**

**3 Overview**

**4 Installation**

**5 Commissioning**

**6 Troubleshooting**

**7 Specifications**

**8 Appendix**

# Table of Contents

---

- 1. Introduction.....1
  - 1.1 Inverter Description.....1
  - 1.2 Included Components .....4
  - 1.3 Tools Required for Installation .....4
  - 1.4 Inverter Storage .....5
- 2. Safety & Warning.....6
  - 2.1 Safety .....6
  - 2.2 General Safety Instructions .....6
  - 2.3 Notice for Use.....8
  - 2.4 Notice for Disposal .....8
  - 2.5 Protection Circuitry and Controls.....8
- 3. Overview.....9
  - 3.1 LED Indicator Lights.....9
  - 3.2 Inverter Wire Box and Connection Points.....10
- 4. Installation.....11
  - 4.1 Selecting a Location to Install the Inverter.....11
  - 4.2 Product Handling.....13
  - 4.3 Mounting the Inverter.....14
  - 4.4 Inverter Wiring Overview.....17
  - 4.5 External Grounding.....18
  - 4.6 PV Cable Installation.....19
  - 4.7 Rapid Shutdown.....20
  - 4.8 Battery Cable Installation.....22
  - 4.9 AC Wiring.....23
  - 4.10 Inverter Communication.....27
- 5. Commissioning.....31
  - 5.1 Pre-Commissioning Steps.....31
  - 5.2 Commissioning Procedure.....31
- 6. Troubleshooting.....37
- 7. Specifications.....41
- 8. Appendix.....50
  - 8.1 Single Line Diagrams.....50
  - 8.2 Frequently Asked Questions.....52
  - 8.3 Temperature Derating Curve.....54
  - 8.4 Inverter Internal Topology.....54
  - 8.5 UL Certification.....55



# 1. Introduction

## 1.1 Inverter Description

The Solis S6 Hybrid series is designed for residential applications. The inverter can work with high-voltage lithium ion batteries to maximize self-consumption and provide backup power if the grid fails and there is not enough PV power to cover load demand.

This inverter can operate in both on-grid and off-grid applications.

The S6 hybrid series consists of the following inverter models: 3.8kW, 5kW, 7.6kW, 10kW, and 11.4kW. The 3.8-5K models are of a similar but different hardware platform than the 7.6-11.4K models. The inverter comes with an integrated rapid shutdown transmitter.

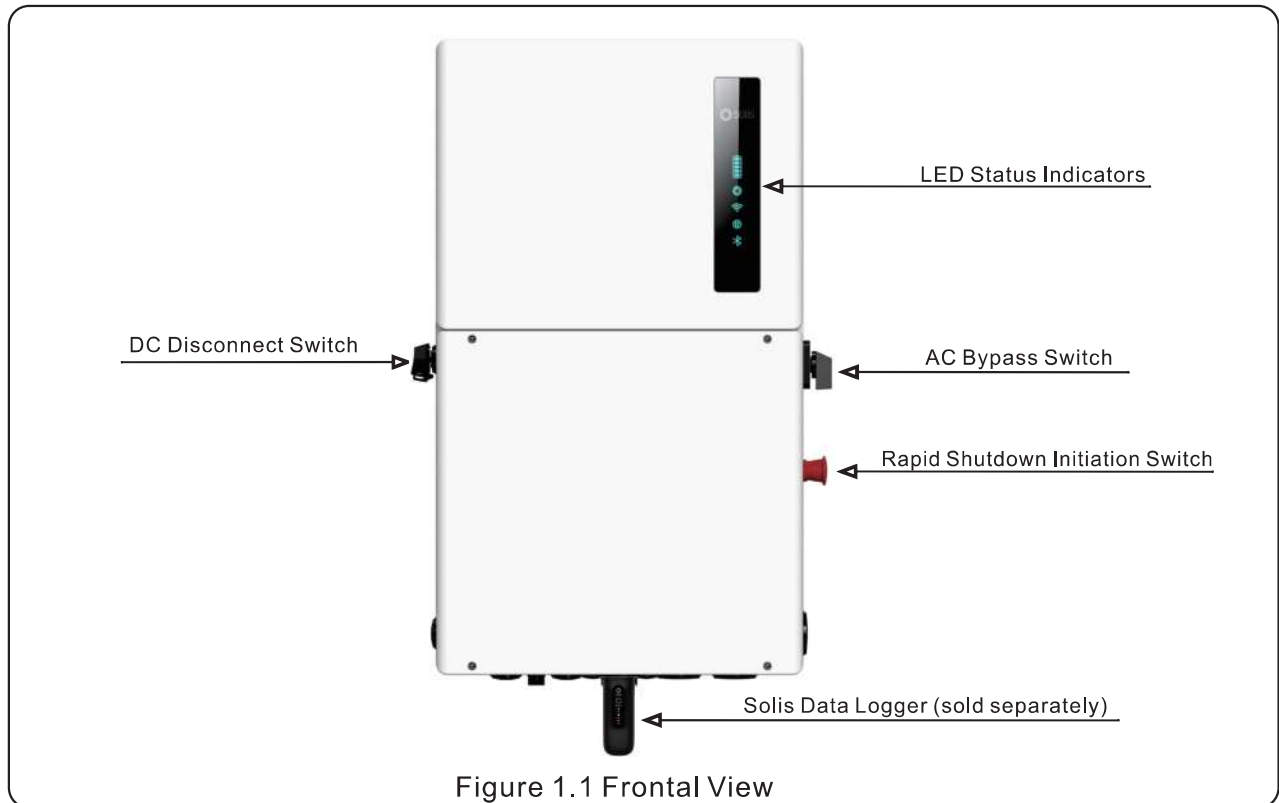

Figure 1.1 Frontal View

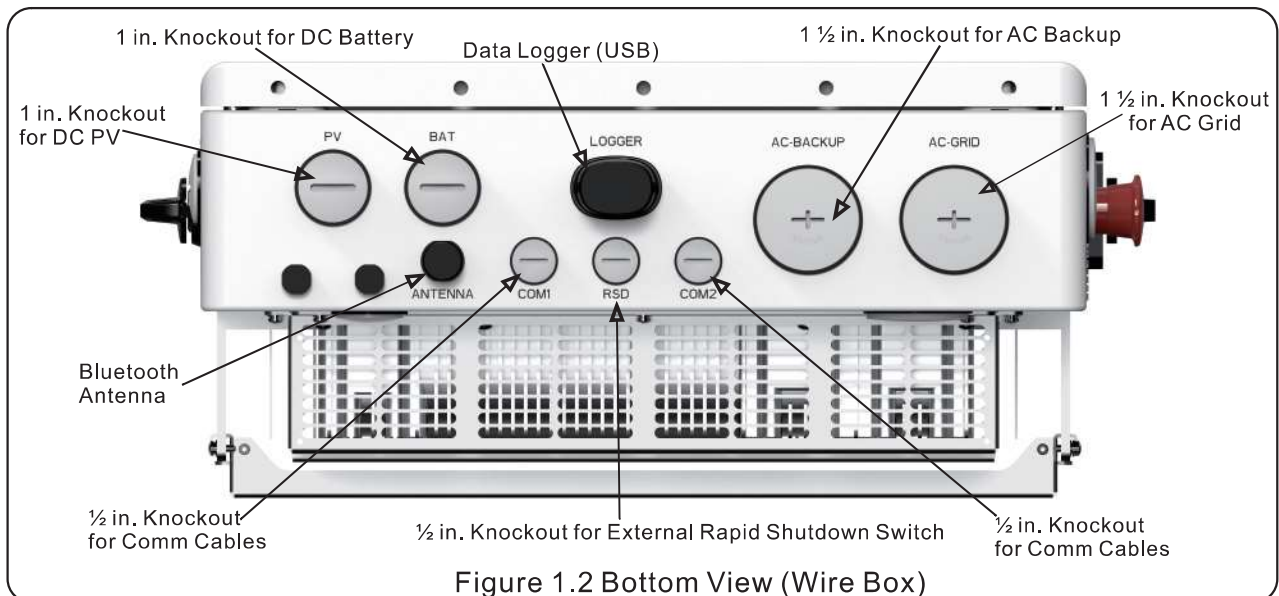

Figure 1.2 Bottom View (Wire Box)

# 1. Introduction

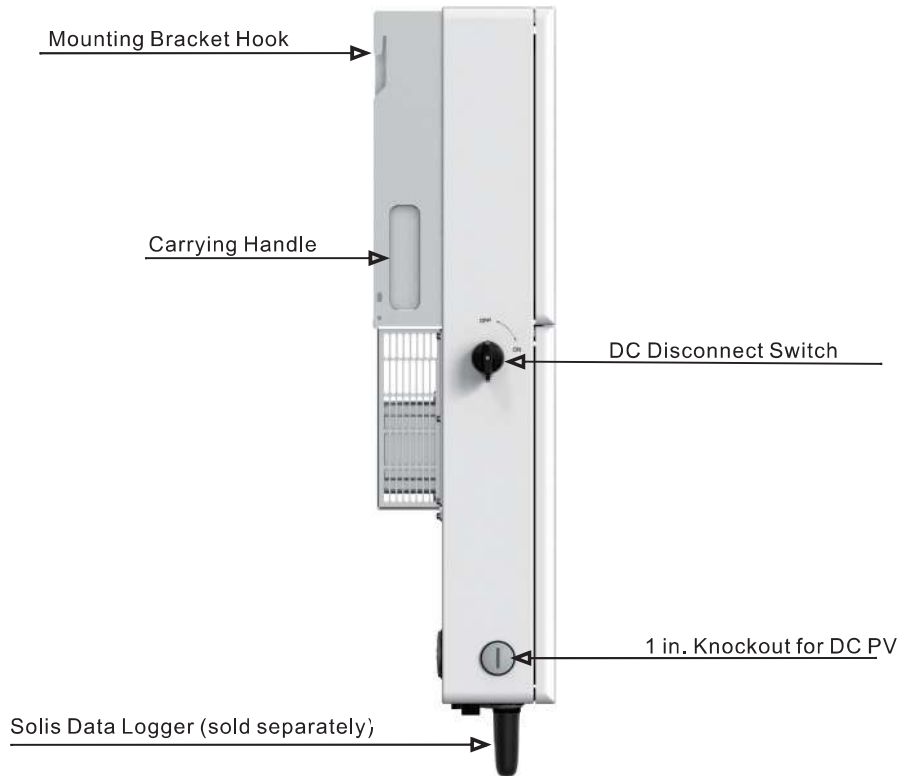

Figure 1.3 Right Side View

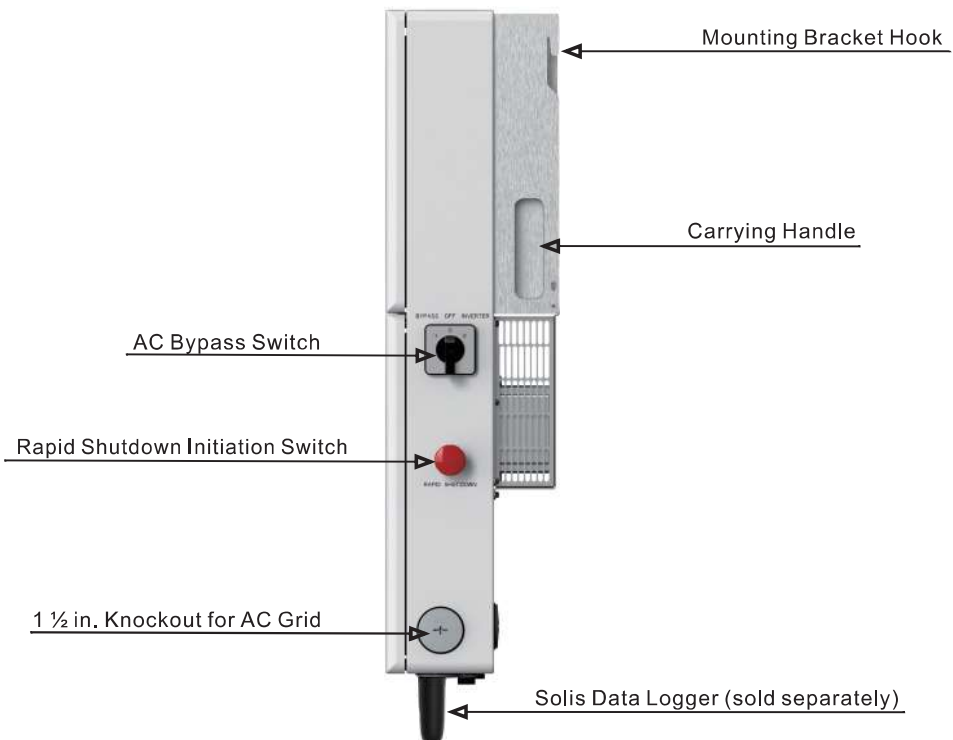
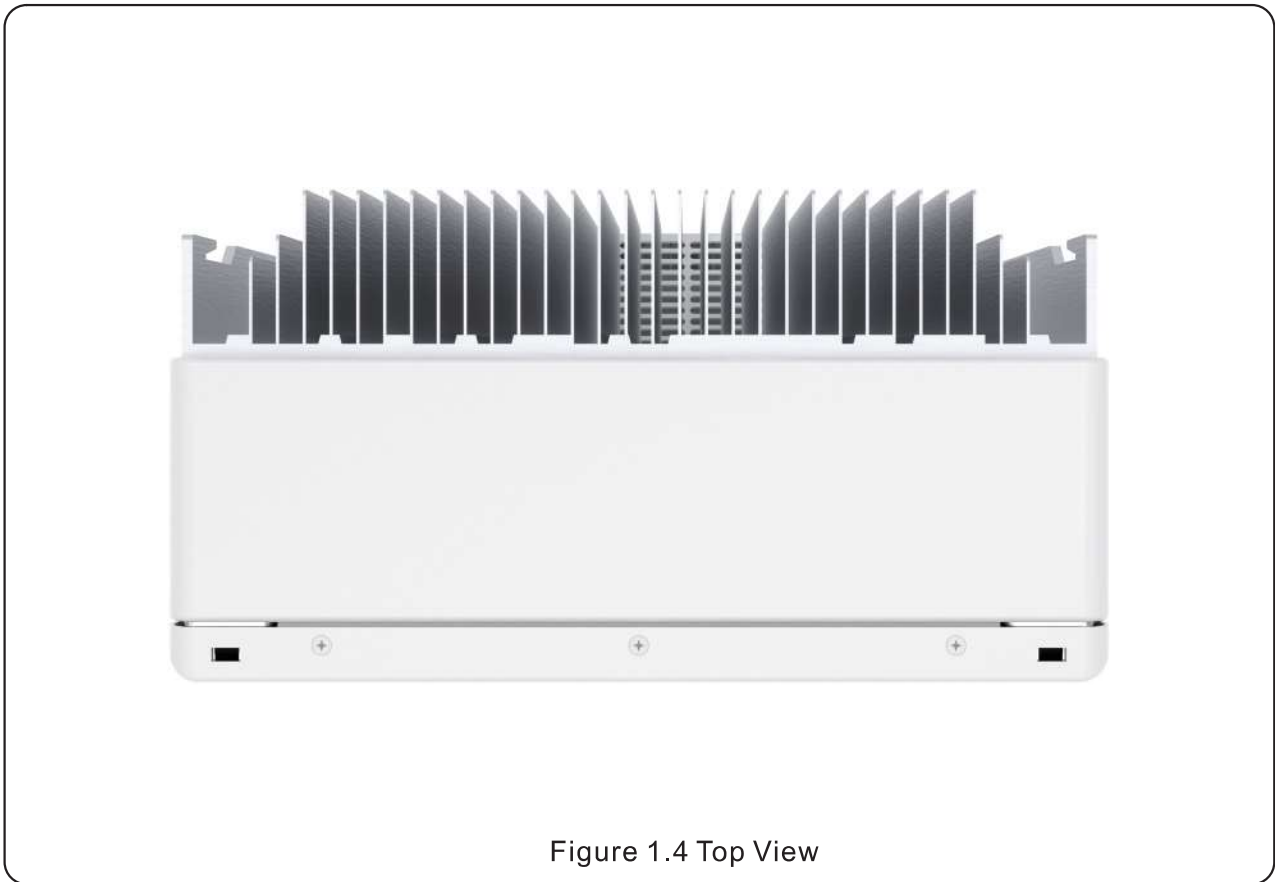
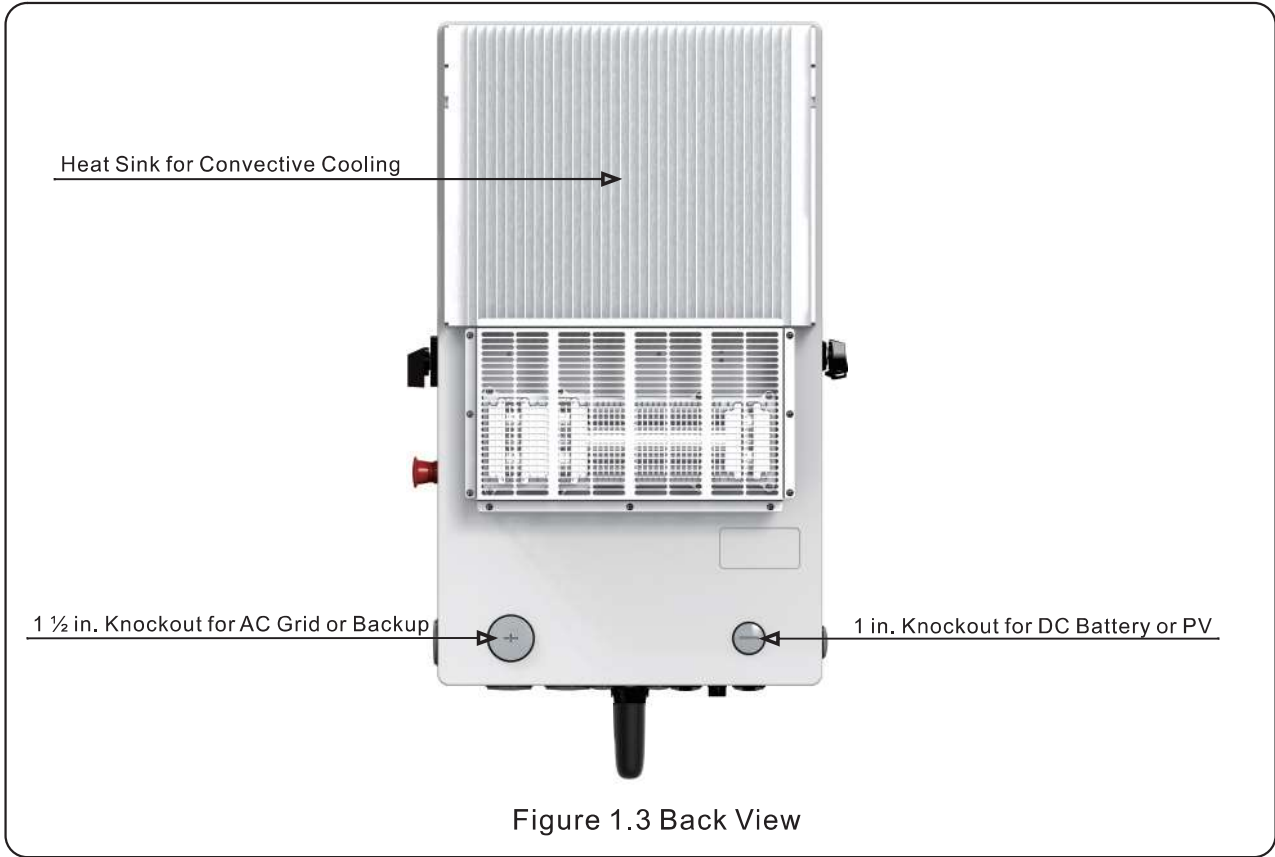

Figure 1.4 Left Side View

# 1. Introduction



# 1. Introduction

## 1.2 Components Included with the Inverter

If any of these items are missing, please contact your local Solis distributor or the Solis service team.

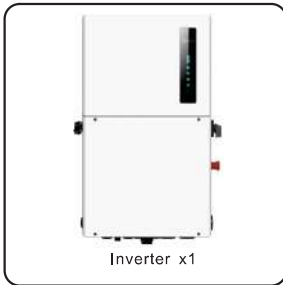

## 1.3 Tools Required for Inverter Installation



# 1. Introduction

---

## 1.4 Inverter Storage

- If the inverter is not installed immediately, please abide by the storage instructions and environmental conditions listed below.
- Use the original box to repackage the inverter, seal with adhesive tape with the desiccant inside the box.
- Store the inverter in a clean and dry place, free of dust and dirt. The storage temperature must be between -40~158°F and humidity should be between 0 to 100%, non-condensing.
- Do not stack more than two (2) inverters high on a single pallet. Do not stack more than 2 pallets high.
- Keep the box(es) away from corrosive materials to avoid damage to the inverter enclosure.
- Inspect the packaging regularly. If packaging is damaged (wet, pest damages, etc.), repackage the inverter immediately.
- Store inverters on a flat, hard surface -- not inclined or upside down.
- After 100 days of storage, the inverter and carton must be inspected for physical damage before installing. If stored for more than 1 year, the inverter needs to be fully examined and tested by qualified service or electrical personnel before using.
- Restarting after a long period of non-use requires the equipment be inspected and, in some cases, the removal of oxidation and dust that has settled inside the equipment will be required.
- Perform an annual visual inspection of the inverter box for signs of damage
- If the inverter has been removed from the box and then replaced, put desiccant packets in the inverter wire box to ensure the internal components stay dry
- Power up the inverter with a DC power supply annually for 5-10 minutes



**DO NOT STACK  
MORE THAN 2 HIGH**

## 2. Safety & Warning

---

### 2.1 Safety

The following types of safety instructions and general information appear in this document as described below:



#### **DANGER**

“Danger” indicates a hazardous situation which if not avoided, will result in death or serious injury.



#### **WARNING**

“Warning” indicates a hazardous situation which if not avoided, could result in death or serious injury.



#### **CAUTION**

“Caution” indicates a hazardous situation which if not avoided, could result in minor or moderate injury.



#### **NOTE**

“Note” provides tips that are valuable for the optimal operation of your product.



#### **WARNING: Risk of fire**

Despite careful construction, electrical devices can cause fires.

- Do not install the inverter in an area containing flammable materials or gases.
- Do not install the inverter in a potentially explosive atmosphere.

### 2.2 General Safety Instructions



#### **WARNING**

Only devices in compliance with SELV (EN 69050) may be connected to the RS485 and USB interfaces.



#### **WARNING**

Do not connect PV array positive (+) or negative (-) to ground, doing so could cause serious damage to the inverter.



#### **WARNING**

Electrical installations must be done in accordance with local and national electrical safety standards.



#### **WARNING**

Do not touch any internal parts until 5 minutes after disconnection from the utility grid, PV array, and battery.

## 2. Safety & Warning



### **WARNING**

To reduce the risk of fire, over-current protective devices (OCPD) are required for all circuits connected to the inverter. The DC OCPD shall be installed per local requirements. All photovoltaic source and output circuit conductors shall have isolators that comply with the NEC Article 690, Part II. All Solis single phase inverters feature an integrated DC disconnect switch.



### **CAUTION**

Risk of electric shock, do not remove the cover. There are no serviceable parts inside, refer servicing to qualified and accredited service technicians.



### **CAUTION**

The PV conductors are energized with high voltage DC when the PV modules are exposed to sunlight.



### **CAUTION**

The surface temperature of the inverter can reach up to 75°C (167°F). To avoid risk of burns, do not touch the surface of the inverter while it is operating. The inverter must be installed out of direct sunlight exposure.



### **NOTE**

PV modules used with inverter must have an IEC 61730 Class A rating.



### **WARNING**

Operations must be accomplished by a licensed electrician or a person authorized by Solis.



### **WARNING**

Installer must wear personal protective equipment during the entire installation process in case of electrical hazards.



### **WARNING**

The AC Backup Port of the inverter cannot be connected to the grid.



### **WARNING**

Please refer to the product manual of the battery before installation and configuration to the inverter.



**Systems using this product shall be designed and built in accordance with the NEC & local electrical codes & standards.**

## 2. Safety & Warning

---

### 2.3 Notice for Use

The inverter has been constructed according to the applicable safety and technical guidelines. Use the inverter in installations that meet the following specifications only:

1. Permanent installation is required.
2. The electrical installation must be compliant with all local and national regulations & standards.
3. The inverter must be installed according to the instructions stated in this manual.
4. The inverter must be installed according to the inverter technical specifications.

### 2.4 Notice for Disposal

This product shall not be disposed of with household waste. It must be segregated and brought to an appropriate disposal facility to ensure proper recycling.

This it to be done in order to avoid negative impacts on the environment and human health.

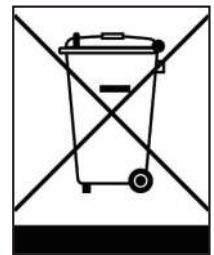

Local waste management rules shall be observed and respected.

### 2.5 Protection Circuitry and Controls

To meet relevant codes and standards, the Solis U.S. single phase inverter line is equipped with protective circuitry and controls. These include Arc Fault Circuit Interrupter (AFCI) and Anti-Islanding Protection.

#### **Arc Fault Circuit Interrupter AFCI:**

Edition 2011 of the National Electrical Code®, Section 690.11, requires that all PV plants attached to a building are fitted with a means of detecting and interrupting serial electric arcs in the PV wiring and array. An electric arc with a power of 300W or greater must be interrupted by the AFCI in the time specified by UL 1699B. After five arc fault detections in 24 hours, an AFCI-induced shutdown will be triggered. If this event occurs, the inverter must be manually reset. After clearing the source of the fault, the inverter can be powered back on and allowed to resume normal operation.

#### **Anti-Islanding Protection:**





Anti-Islanding is a condition where the inverter cease to produce power when the grid is not present. Circuitry, along with firmware, has been designed to determine if the grid is present by adjusting the output frequency of the inverter. In the case of a 60Hz resonant system where the inverter is partially isolated from the grid, the inverter programming can detect if there is a resonant condition or if the grid is actually present. It can also differentiate between inverters operating in parallel and the grid.



# 3. Overview

## 3.1 LED Indicator Lights

There are five indicator lights on the the Solis S6-EH1P(3.8-11.4)K-H-US Series Inverter: Battery, Inverter, Wi-Fi, RS485 and Bluetooth. These lights indicate the working status of the inverter. The inverter creates a Bluetooth signal which is what the smart phone connects to so that the inverter interface page can be accessed. This is how commissioning and settings changes are performed.

Light	Status	Description
 Battery	Blue Flashing every 3s	Battery is discharging
	Blue Flashing every 1.5s	Battery is charging
	Blue Solid ON	Battery is idle
	Yellow Solid ON	Battery has an alarm
 Inverter	Blue Solid ON	Inverter is operating normally
	Yellow Solid ON	Inverter has a warning alarm
	Red Solid ON	Inverter has a critical alarm
 Wi-Fi	Blue Solid ON	The data logger port is being used
	OFF	The data logger port is not being used
 RS485	Blue Solid ON	The RS485 port is being used
	OFF	The Rs485 port is not being used
 Bluetooth	Blue Solid ON	The Bluetooth network is enabled
	OFF	The Bluetooth network is disabled

### Turning On the LED Indicator Lights

After a few minutes, the LED indicator lights will turn off to conserve power. To turn the lights back on, short-press the Inverter LED light.



### Alarm State

When the inverter has an alarm, the Inverter LED light turns red and starts flashing. It is recommended to connect to the inverter with the Bluetooth tool. Then you can determine what the alarm code is.



### NOTE:

Battery/Wi-Fi/RS485/Bluetooth indicators will automatically turn off after 1 minute. The Inverter indicator will remain on with lower brightness. Short press the Inverter indicator to wake up the other indicators.

# 3. Overview

## 3.2 Inverter Wire Box and Connection Points

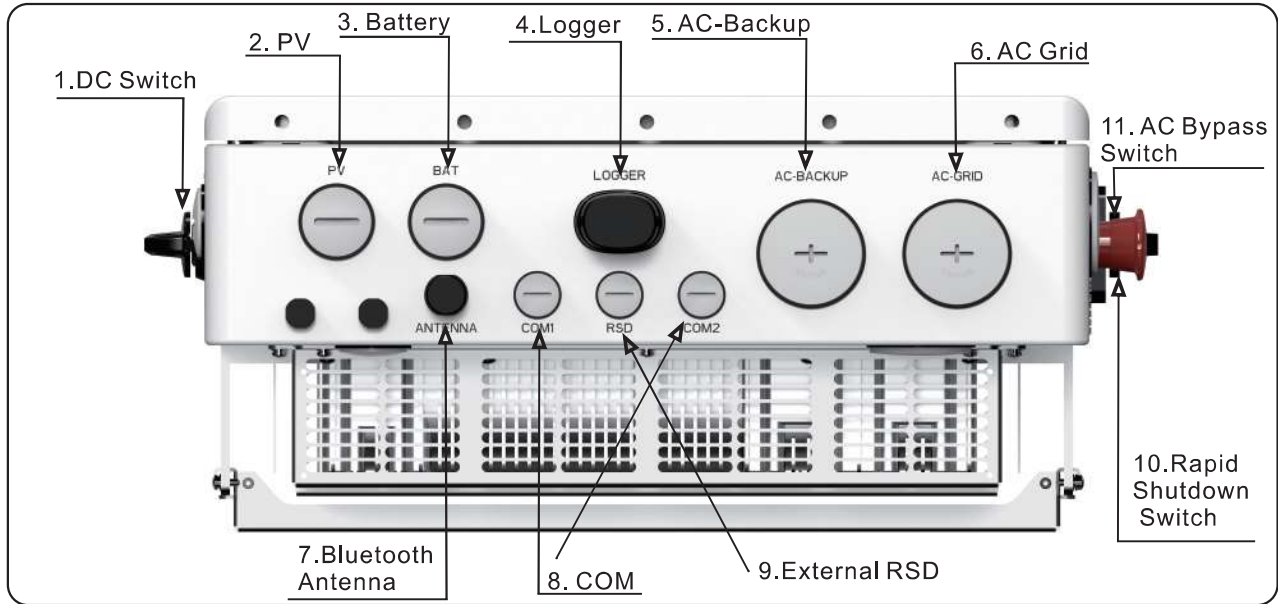

Name	Description
1. DC Switch	This is the DC disconnect switch for the PV
2. PV	Conduit for PV conductors should be connected here
3. Battery	Conduit for battery conductors should be connected here
4. Solis Logger	Solis data logger gets connected here - only USB versions of the loggers will work
5. AC-Backup	Conduit for AC conductors to backup loads panel should be connected here
6. AC-Grid	Conduit for AC conductors to the main service panel should be connected here
7. Bluetooth Antenna	Extends the range of the inverter Bluetooth signal (for system commissioning)
8. COM1/COM2	RS 485 and CAN communication cables should go through these - use cable glands
9. External RSD	An external RSD switch can be added and connected to the inverter through here
10. Rapid Shutdown Switch	Turns off the internal transmitter which initiates module level rapid shutdown
11. AC Bypass Switch	Allows the inverter to pass power through from the grid (main service panel) to the backup loads directly in the event of an inverter failure.

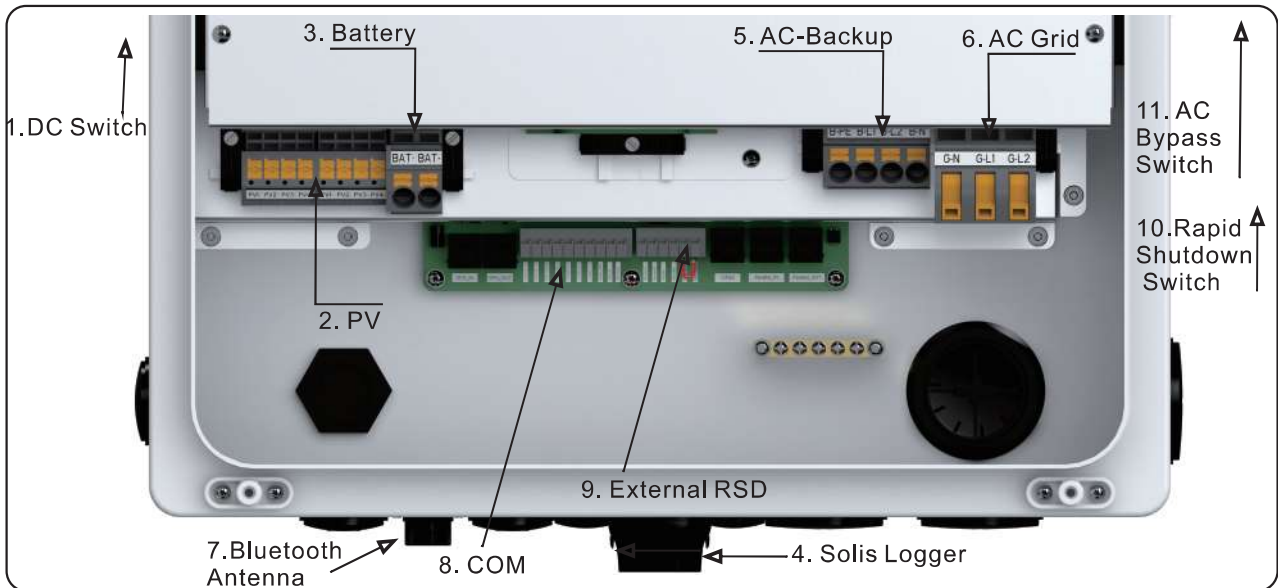

## 4. Installation

### 4.1 Select a Location to Install the Inverter

When selecting a location for the inverter, the following criteria should be considered:

- Exposure to direct sunlight may cause output power derating due to overheating  
It is recommended to avoid installing the inverter in direct sunlight. The ideal location is one where the ambient temperature does not exceed 40°C (140°F)
- It is also recommended to install the inverter somewhere the rain and snow will not land directly on it. The ideal installation location is on a north-facing wall under an eave.

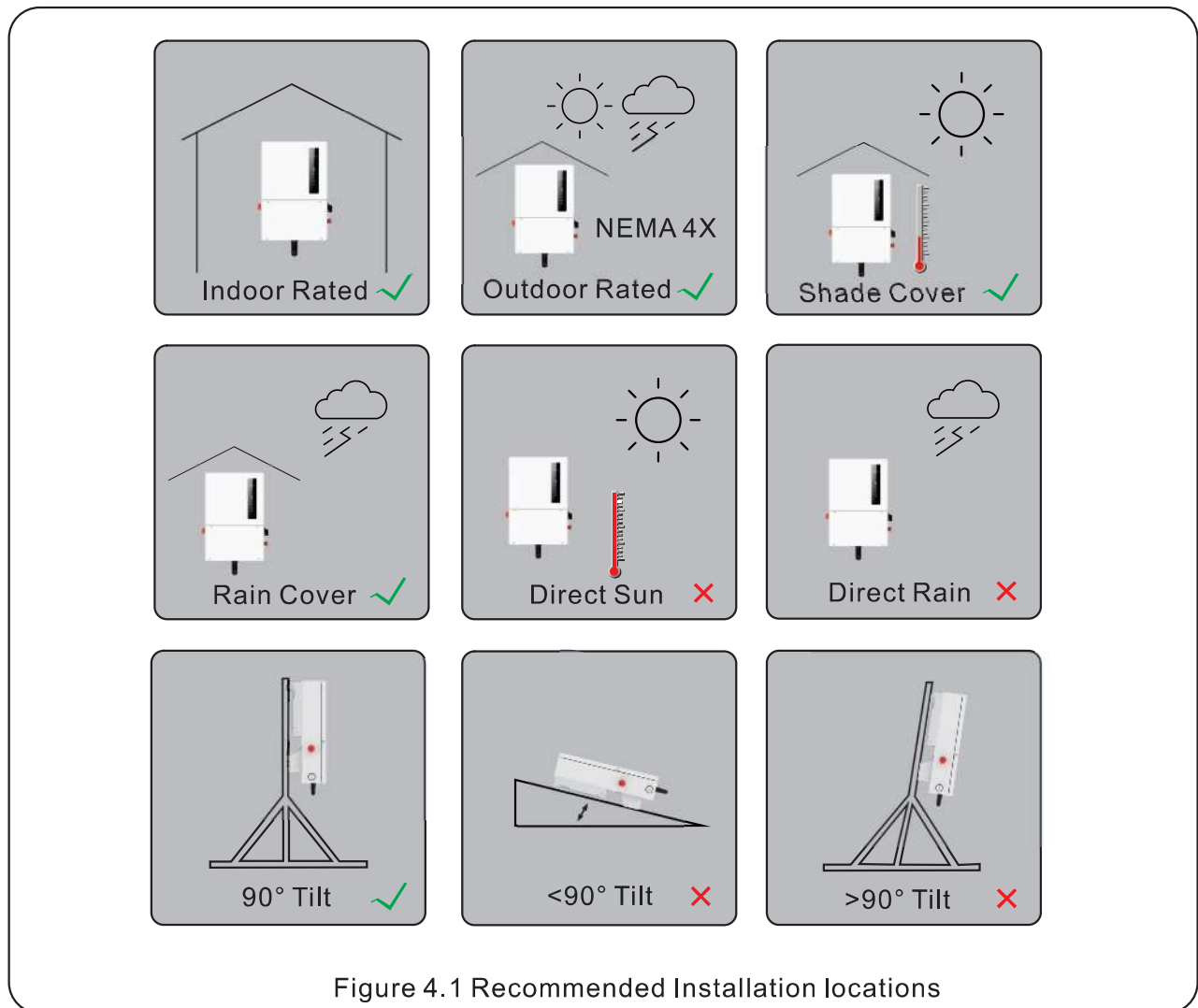

#### **WARNING: Risk of fire**

Despite careful installation, electrical equipment can cause fires.

- Do not install the inverter in an area containing flammable materials or gases.
- Do not install the inverter in a potentially explosive environment.
- The structure where the inverter is being mounted must be fireproof.

# 4. Installation

## 4.1 Selecting a Location to Install the Inverter

When selecting a location for the inverter, consider the following:

**WARNING: Risk of fire**



Despite careful construction, electrical devices can cause fires.

- Do not install the inverter in areas containing highly flammable materials or gases. Keep the inverter out of reach of children if children may be present.
- Do not install the inverter in potentially explosive environments.

**CAUTION: Hot Surface**



- The temperature of the inverter heat sink can reach 167°F. Do not touch the heat sink while the inverter is operating.

The ambient temperature and relative humidity of the installation environment should meet the following requirements:







<b>Maximum Temperature</b>  140°F 60°C	<b>Minimum Temperature</b>  -24°F -31°C	<b>Max. Relative Humidity</b>  100% Non-Condensing	<b>Maximum Altitude</b>  13,123 feet 4,000 meters
---	--	---	--

Figure 4.2 Installation environment conditions

**Load bearing structure requirements:**



Made of nonflammable materials



Max. load bearing capacity  $\geq 4$  times of inverter weight



Figure 4.3 Load bearing structure

### 4.1.1 Clearances

- If multiple inverters are installed on site, a minimum clearance of 12 inches should be kept between each inverter and all other mounted equipment. The bottom of the inverter should be at least 20 inches above of the ground or floor (see Figure 4.5 on page 12).
- The LED status indicator lights located on the inverter's front panel should not be blocked
- Adequate ventilation must be present if the inverter is to be installed in a confined space.

### 4.1.2 Consult technical data

- Consult the technical specifications sections at the end of this manual for additional environmental condition requirements (temperature range, altitude, etc.)

### 4.1.3 Angle of installation

- This model of Solis inverter must be mounted vertically (90° degrees not greater or less than 90° degrees straight up).

# 3. Installation

## 4.1.4 Avoiding direct sunlight

Installation of the inverter in a location exposed to direct sunlight should be avoided.

Direct exposure to sunlight could cause:

- Power output limitation (with a resulting decreased energy production by the system).
- Premature wear of the electrical/electromechanical components.
- Premature wear of the mechanical components (gaskets) and user interface.

## 4.1.5 Air circulation

Do not install in small, closed rooms where air cannot freely circulate. To prevent overheating, always ensure that the air flow around the inverter is not blocked.

## 4.1.6 Flammable substances

Do not install near flammable substances. Maintain a minimum distance of ten feet (three meters) from such substances.

## 4.1.7 Living area

Do not install in a living area where the prolonged presence of people or animals is expected. Depending on where the inverter is installed (for example: the type of surface around the inverter, the general properties of the room, etc.) and the quality of the electricity supply, the sound level from the inverter can be quite high.

## 4.2 Product Handling

Please review the instruction below for handling the inverter:

1. The red circle below denotes the carrying handle cutout on the inverter box. Push in the cutouts on both ends of the box to form handles for moving the inverter (see Figure 4.4).

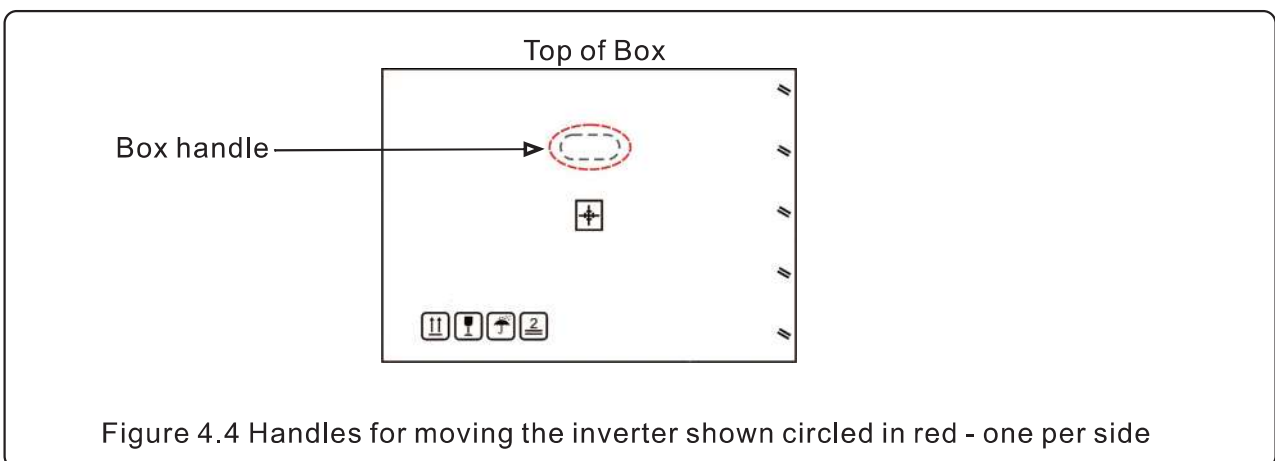

2. Two people are required to carry and move the inverter while it is in the box.
3. When removing the inverter from the box, two people must use the handles integrated into the heat sink. (see Figures 1.3 and 1.4 on page 2)
4. When setting the inverter down, do it slowly and gently. This ensures that the internal components and the outer chassis do not take any damage.

# 4. Installation

## 4.3 Mounting the Inverter

- Mount the inverter on a wall or structure capable of bearing the weight of the machine
- The inverter must be mounted upright on a vertical structure with a tilt of 90°. A tilt greater or less than 90° may cause the inverter output power to derate.
- To prevent overheating, be sure that the inverter has adequate air flow around it. A minimum clearance of 12 inches (305mm) should be kept between inverter & other equipment. 20 inches (508mm) of clearance between the bottom of the inverter and the ground.

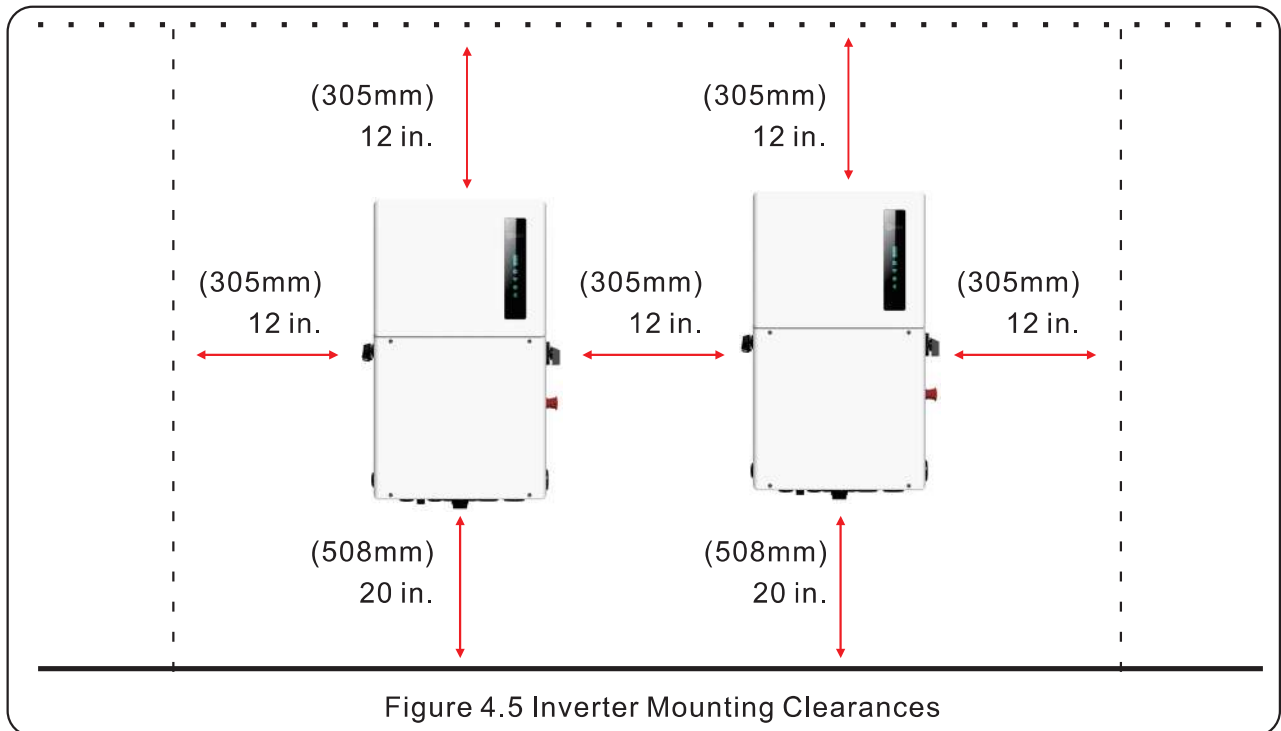

- Visibility of the LED indicator lights should be considered. Ideally, the indicator light should be at eye-level.
- Adequate ventilation around the inverter must be provided.



**NOTE:**

Nothing should be stored directly on top, underneath, or against the inverter.

- When the inverter is mounted on the wall, it sticks out approximately 9.5 inches. Keep this in mind when selecting the installation location for the inverter.
- The exact dimensions of the inverter and the mounting bracket are on the next page.



**NOTE:**

The inverter does not come with any fasteners. You must provide your own hardware for securing the mounting bracket to the mounting structure.

# 4. Installation

## 4.3 Mounting the Inverter

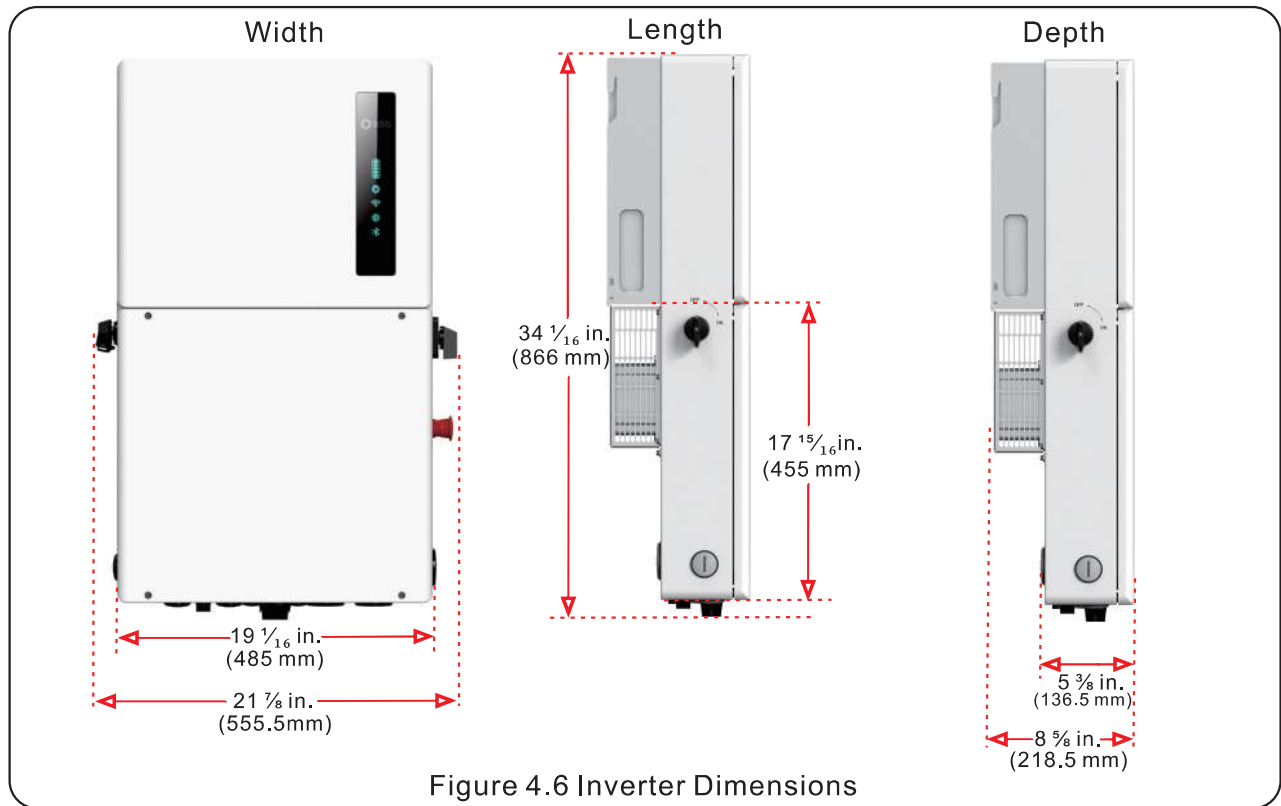

Figure 4.6 Inverter Dimensions

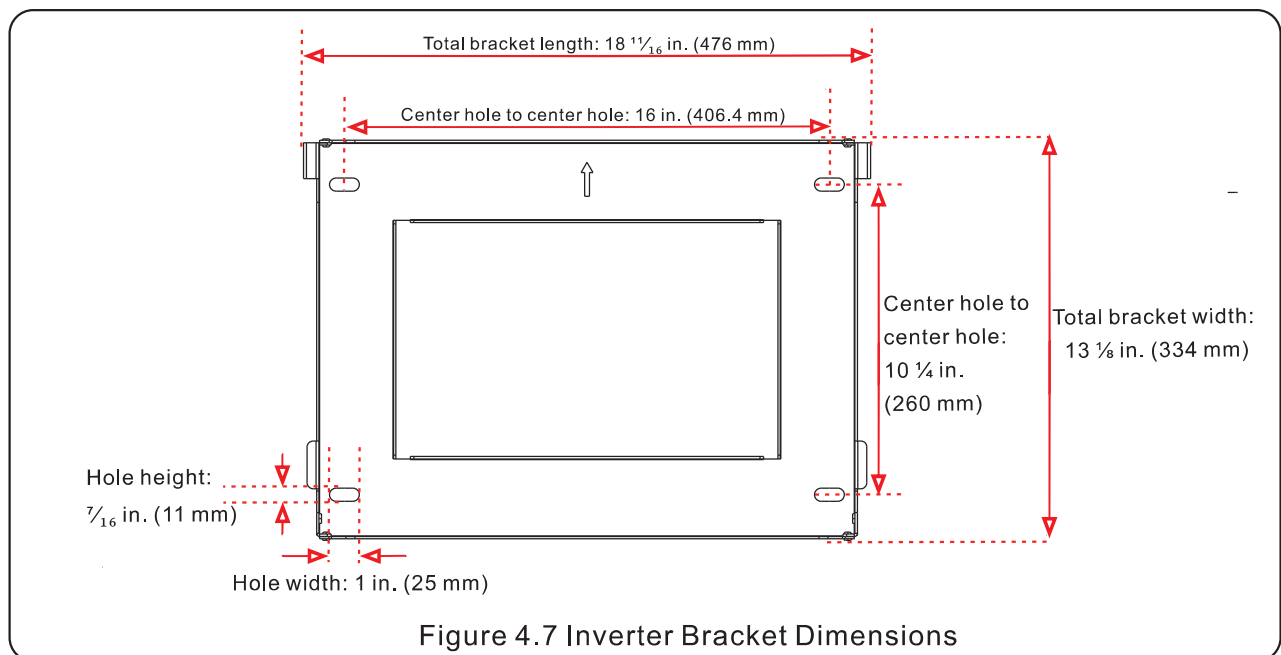

Figure 4.7 Inverter Bracket Dimensions

Once a suitable location has been found according to 4.2 and 4.3, use figures 4.6 and 4.7 to mount the bracket to the wall. You may drill additional holes in the bracket if you need to. The steps to mount the inverter are listed below:

1. Place the bracket on the wall and use a bubble level to make sure it is level. The arrow in the middle of the bracket points up. With a pencil or marker, mark the mounting holes. Use a drill to prepare the holes for fasteners. Fasten the bracket to the wall.



## 4. Installation



**NOTE:**

The inverter must be mounted vertically at a 90° angle.  
Four fasteners must be used to ensure the bracket does not come off the wall. At least two must embed in a wall stud to bear the inverter weight.

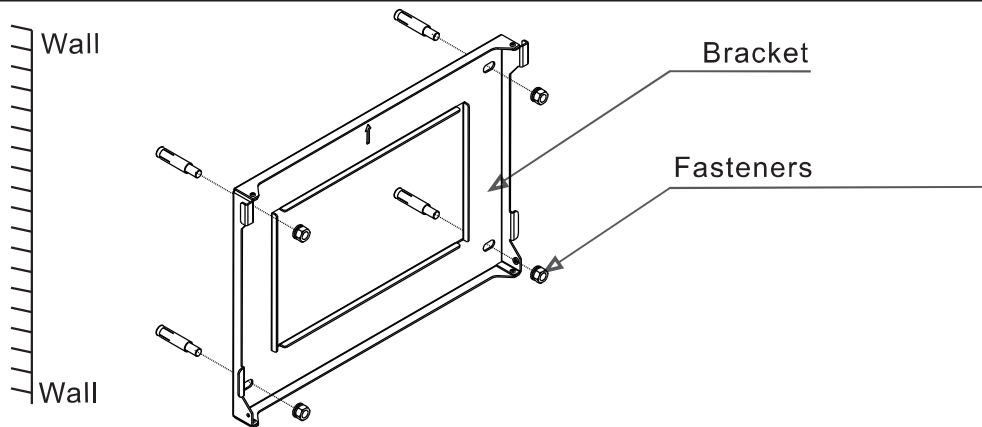

Figure 4.8 Fix the bracket to the wall

2. Lift up the inverter and align the back two hooks on the heat sync with the two tabs on the inverter mounting bracket. Lower the inverter hooks down onto the mounting bracket tabs and ensure the hooks have a solid bite before releasing the inverter. Then install the two set screws that are included with the inverter for stabilization. (see Figure 4.9)

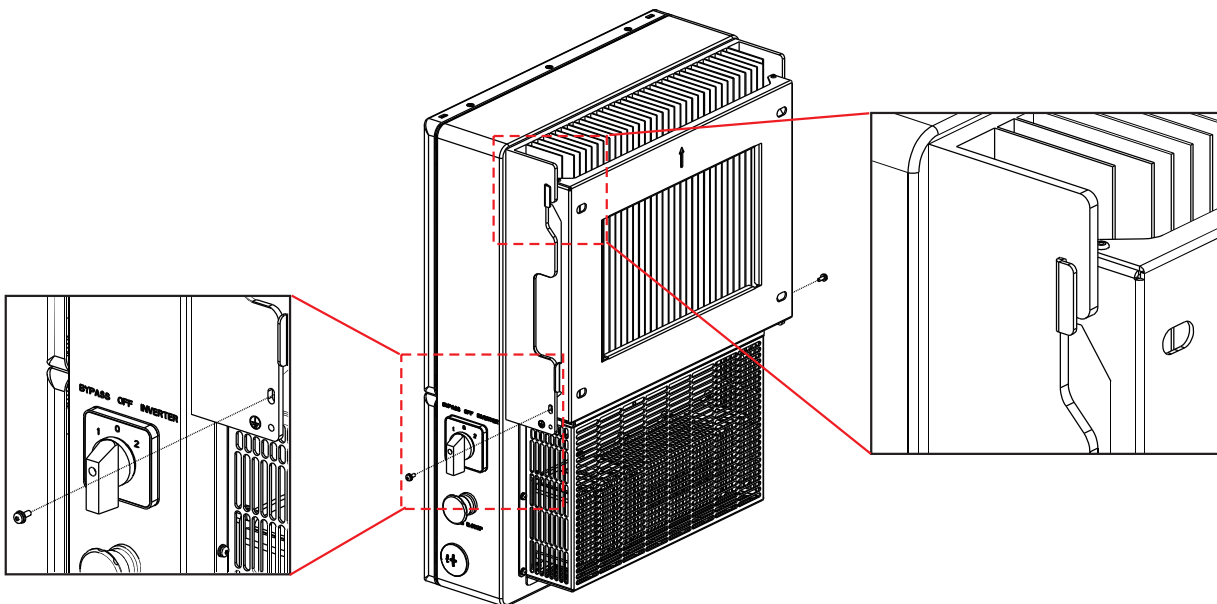

Figure 4.9 Inverter on mounting bracket and set screws



**WARNING:**

The inverter is very heavy. Please use proper lifting techniques to avoid potential injury. It is recommended that two people lift the inverter.



## 4. Installation

### 4.4 Inverter Wiring Overview

	Purpose	Connection Points
PV Cables	PV DC connection to the inverter	From the PV array to the DC+ and DC- terminals in the inverter
Battery Cables	Battery DC connection to the inverter	From the battery (+) and (-) terminals to the inverter BAT+ and BAT- terminals
AC Grid Cables	Inverter AC connection to the main service panel	From the OCPD in the main service panel to the AC-GRID L1 and L2 terminals
AC Backup Cables	Inverter AC connection to the backup subpanel	From the backup loads subpanel OCPD to the inverter AC-BACKUP L1 and L2 terminals
Ground Cables	Grounding conductors for the system	From the main service panel ground bar to the ground bar inside the inverter wire box
Meter RS 485 cable	Communication between inverter & meter	From meter to terminal Meter_A and Meter_B. For more details, refer to figure 4.2.2 Installing the energy meter
Battery CAN cable	Communication between the inverter & the battery	From battery to terminal CAN-L and CAN-H. For more details, refer to figure 4.2.3 Installing the battery
Data Logger (Optional)	Monitoring of the system on SolisCloud	USB COM port at the bottom of the inverter (For more details, please refer to the Solis data logger product manual)

Table 4.1 System Cable Connections



**Conductor, conduit, and overcurrent protection device sizing shall be done in accordance with the NEC and local electrical codes & standards.**

The Appendix section of this manual contains single-line wire diagrams that show how the equipment interconnects. Please use the single-line diagram when planning the conduit paths and determining the wire requirements.

## 4. Installation

### 4.5 External Grounding

An optional external ground connection point is available on the right side of inverter. The internal ground bar is grounded to the inverter chassis.

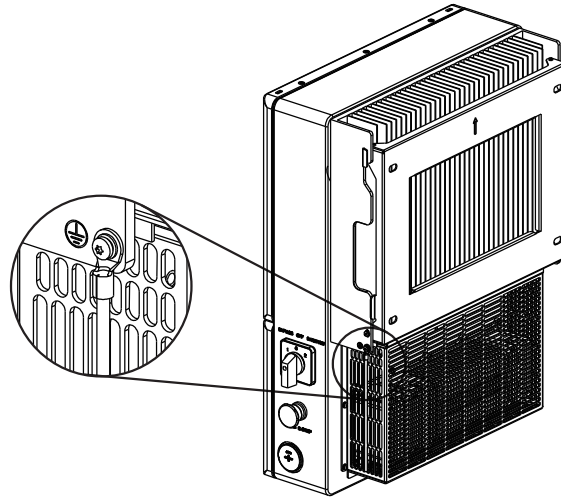

Figure 4.10 External Grounding Conductor Terminal Location

To connect the grounding terminal on the heat sink, please follow the steps below:

1. It is recommended to use copper wire for the chassis ground. Either solid conductor or stranded wire is acceptable. Refer to local code standard for wire sizing.
2. Strip  $\frac{1}{2}$  inch of insulation off the end of the ground cable (see Figure 4.7)



**Important:**

For multiple inverters in parallel, all inverters should be connected to the same ground point to eliminate the possibility of a voltage potential existing between inverter grounds.

3. Crimp a ring terminal onto the ground cable with a ratcheting crimp tool
4. Connect the cable to the ground terminal screw and then tighten it with a torque wrench screwdriver to 2N.m.

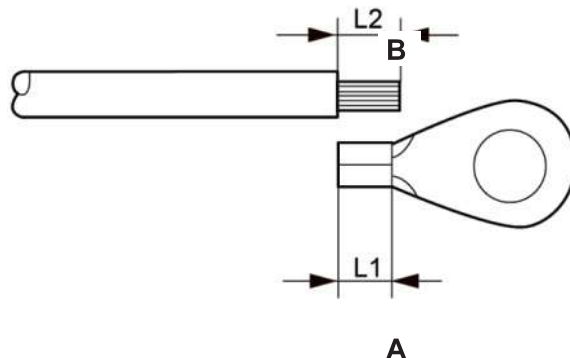

Figure 4.11 External Grounding Conductor Ring Terminal

## 4. Installation

### 4.6 PV Cable Installation



**Danger:**

Before installing the PV cables, be sure that the PV array is disconnected. Use a multimeter to verify that the PV string voltages are 0V before proceeding. If rapid shutdown is being used, then under 30Vdc per string is safe.

Please verify the following before connecting the PV strings to the inverter:

- Ensure the DC voltage of the PV strings will not exceed the maximum DC input voltage (600Vdc). Violating this condition will void the inverter warranty.
- Ensure the polarity of the PV strings are correct (ex: positive is positive).
- Ensure the DC-switch, battery, AC-BACKUP, and AC-Grid OCPDs are all off.
- Ensure the PV resistance to ground is higher than 20K ohms.
- Ensure that the Isc of the strings will not exceed the maximum DC input current.

**Note:** Each PV string input is a separate MPPT

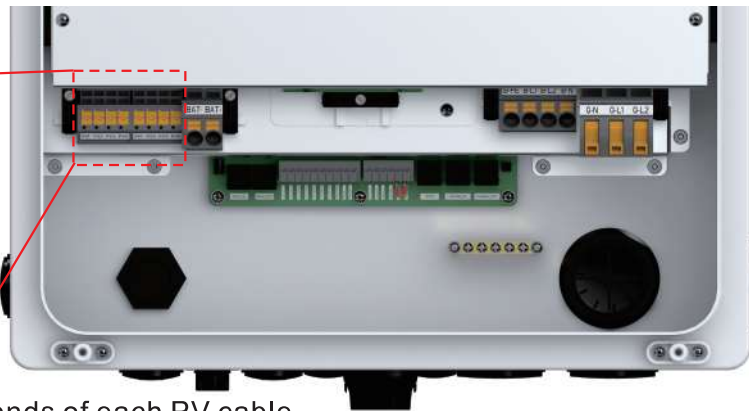
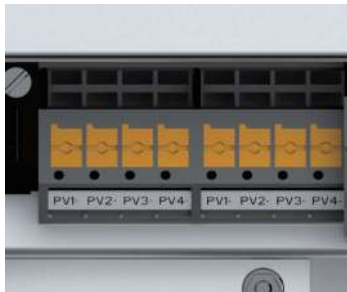

1. Strip ½ inch of sheath off the ends of each PV cable
2. Insert a technician screwdriver into the slot of the yellow square above the terminal
3. Push in with the screwdriver, the terminal will open up
3. Insert the PV cable into the terminal
4. Release the screwdriver and the terminal will clamp down on the PV wire.
5. Give the PV wire a gentle tug test to ensure that the connection is tight.
6. If the connection feels loose, repeat steps 1-5 again

Figure 4.12 PV Cable Connection

**CAUTION:**

If the DC conductors are accidentally connected in reverse or if the inverter is not working properly, do NOT turn off the DC switch. Otherwise, it may cause a DC arc and damage to the inverter or a fire.

The steps for corrective actions are as follows:

- \*Use a DC amp clamp multimeter to measure the DC string current.
- \*If the current is above 0.5A, please wait for the irradiance on the PV array to diminish until the current drops below 0.5A.
- \*Once the current is below 0.5A, you are allowed to open the DC switch and and then disconnect the PV strings from the inverter.
- \* In order to completely eliminate the potential for failure, leave the PV strings disconnected until the cause of the reverse polarity is corrected.



# 4. Installation

## 4.7 Rapid Shutdown

### 4.7.1 Integrated Rapid Shutdown



#### Important Note

The inverter comes (optional) with an internal rapid shutdown transmitter. This transmitter brand must match the receivers that are being installed with the PV modules. **Not abiding by this will void the inverter warranty.**

#### How the inverter achieves module-level rapid shutdown:

The internal transmitter generates a PLC signal when it receives AC power. This signal travels up the PV strings to the receivers that are connected to the PV modules. When the receivers get this signal, they turn on and allow the string voltage to ramp up. When the receivers lose this signal, they turn off. When the receivers are off, each PV module only puts out around 0.6Vdc.

The red “Rapid Shutdown (RSD E-Stop) switch disables the internal transmitter

#### Rapid Shutdown Initiation Process

1. Press the switch button in to turn off the internal transmitter. This will initiate rapid shutdown of the PV (ramps the PV voltage down)
2. Twist the switch clockwise to turn the transmitter back on. This will bring the PV voltage back up to normal.



#### Note:

Rapid shutdown will only initiate if receivers have been installed on the PV modules. Without the receivers, rapid shutdown is not possible.

Figure 4.13 Rapid shutdown initiation switch and process

#### Additional Details About Rapid Shutdown

1. With rapid shutdown receivers installed, the PV string voltages should be very low. Depending on the receiver type, you should be measure between 0.6 and 0.7Vdc per module. Example: x10 modules = 6V-7V for the whole string
2. If the PV string voltages are low, check that the AC breaker is turned on so that the inverter is getting AC voltage and that the rapid shutdown switch is popped out. Give the switch a twist clockwise to verify that is popped out.
3. The DC switch does not have to be turned on for the receivers to receive the PLC signal from the internal transmitter. However, if an external DC switch is installed, ensure that it is turned on or else the receivers will not be able to get the PLC signal from the transmitter.

## 4. Installation

### 4.7.2 External Rapid Shutdown

If the inverter is being installed where it is inaccessible to first responders, an external rapid shutdown switch must be installed somewhere it is accessible.

#### Steps for Installing an External Rapid Shutdown Initiation Switch

1. Install the external RSD switch and run two wires between it and the inverter
2. Remove the red jumper from the RSD\_IN and RSD\_OUT terminals (see Figure 4.14)
3. Connect one end of the two wires to the RSD\_IN and RSD\_OUT terminals
4. Connect the other end of the two wires to the external RSD switch

**Note:** the RSD switch on the inverter wire box will still initiate rapid shutdown. Be sure the transmitter is on by giving the switch a clockwise twist when you are ready to energize the system.

Please contact your local supplier for an external rapid shutdown switch.

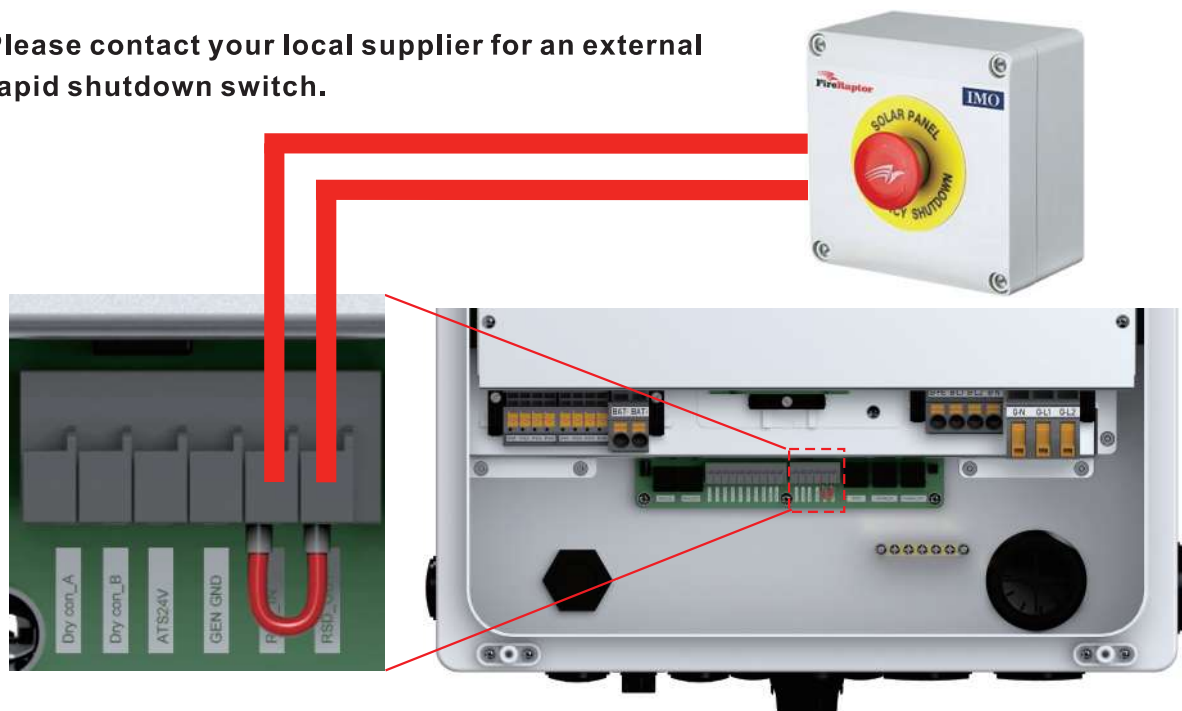

Figure 4.14 External RSD Initiation Switch

#### External Rapid Shutdown Transmitter Guidance

An external transmitter can be installed, but the internal transmitter must be disabled so there is no cross-talk between the two transmitters.

1. Disable the internal transmitter by removing the red jumper (see Figure 4.14)
2. Install the external rapid shutdown transmitter in accordance with the transmitter user manual
3. For the PV to generate power in backup mode, the external transmitter must get power from the inverter backup circuit. You can also take the 12Vdc from the internal transmitter.

**Note:** the red jumper completes the 12Vdc circuit by closing the positive + side

**Please consult the RSD user manuals when installing the RSD components**

# 4. Installation

## 4.8 Battery Installation



**DANGER:**

Before installing the battery cables, be sure that the battery is turned off. Use a multimeter to verify that the battery voltage is 0Vdc before proceeding. Consult the battery product manual for instructions on how to turn it off.

1. The battery (+) and (-) cables shall only be connected to the inverter BAT terminals.
2. Run the cables into the wire box. Strip ½ inch off the ends of each cable.
3. Insert a technician screwdriver into the slots of the squares below the BAT terminals
4. Push in with the screwdriver, insert the cable, and release the screwdriver
5. Give the battery a gentle tug test to ensure the connection is tight
6. If the connection feels loose, repeat steps 1-5

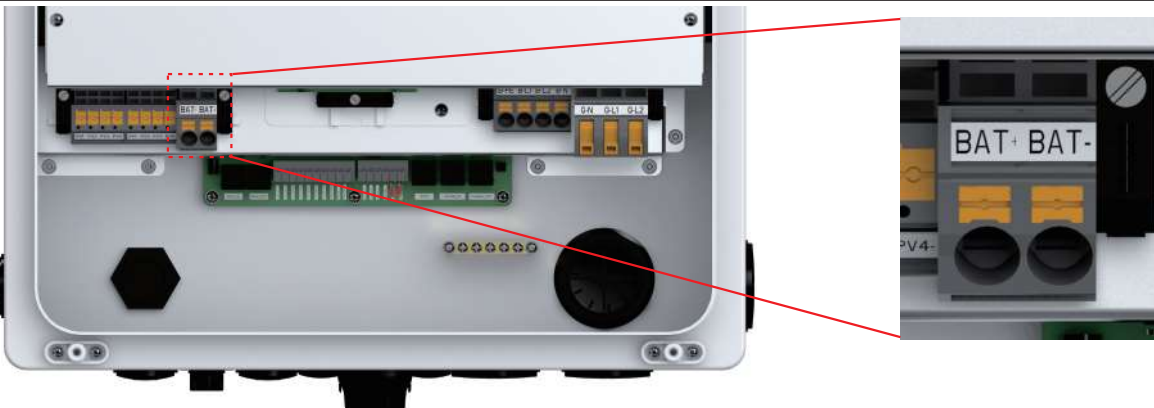

Figure 4.15 Battery Cable Connection

**Additional Notes on Batteries:**

For instructions on how to turn the battery on, please consult the battery user manual and be sure to wait until the system is fully installed before turning the battery on.

This inverter only works with specific battery models. Please consult the Battery Compatibility sheet for specifics on which battery models this inverter will support.



**Note:**

The battery fuse in the inverter wire box is replaceable. The replacement can only be done by a technician authorized by Solis. Fuse specification: 750V, 63A.



**Note:**

Before connecting the battery, please carefully read the product manual of the battery and perform the installation exactly as the battery manufacturer specifies in the manual



# 4. Installation

## 4.9 AC Wiring

### 4.9.1 AC Terminals

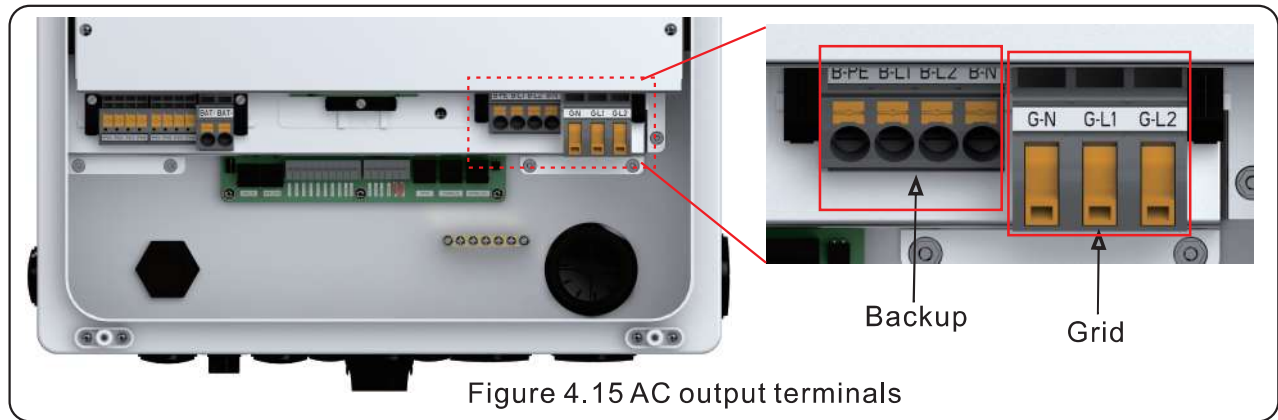

Figure 4.15 AC output terminals

The inverter has two AC outputs: (1) to a backup service panel and (2) to the main service panel which is connected to the utility grid. When utility power is lost, the Grid-side of the inverter shuts off. The Backup-side of the inverter stays energized as long as there is enough PV and battery power to support the loads on the Backup-side. The inverter can be connected to other S6 hybrids in parallel to provide additional support to the backup loads. Generator support will be available in Summer 2023.

Model	S6-EH1P3.8K-H	S6-EH1P5K-H	S6-EH1P7.6K-H	S6-EH1P-10K-H	S6-EH1P-11.4K-H
AC Grid Cable Max. Wire Size Accepted by Terminal	6 AWG	6 AWG	4 AWG	4 AWG	4 AWG
AC Backup Cable Cross Sectional Area	8 AWG	8 AWG	6 AWG	6 AWG	6 AWG

Table 4.3 AC cable size limitations

### Over-Current Protection Device (OCPD) for the AC sides

To protect the inverter, we recommend installing a device for protection against over-current and leakage, based on the following current ratings noted in Table 4.4:

Inverter Model	Grid Max Output Current	Grid Max Input Current	Backup Rated Output Current	Backup Max Output Current (10 sec)
S6-EH1P3.8K-H-US	15.8A	23.8A	15.8A	25.4A
S6-EH1P5K-H-US	20.8A	31.2A	20.8	33.3A
S6-EH1P7.6K-H-US	31.7A	47.6A	31.7A	50.7A
S6-EH1P10K-H-US	41.7A	62.6A	41.7A	66.7A
S6-EH1P11.4K-H-US	47.5A	71.3A	47.5A	76A

Table 4.4 Current ratings for sizing OCPD

## 4. Installation



**Overcurrent protection device and service panel sizing shall be done in accordance with the NEC and local electrical codes and standards.**

### 4.9.2 AC Bypass Switch



**1 is for bypass (failure)**

**0 turns backup off**

**2 is for normal operation**

#### AC Bypass Switch

This failsafe switch determines the power source for the inverter backup circuit. If the inverter fails or has a critical alarm, the backup circuit will shut off. Should this occur, the switch set to 1 allows power to pass through the inverter to the backup from the grid.

The three settings operate as follows:

**1:** backup circuit is powered by the grid directly

**0:** backup circuit is disconnected from the inverter

**2:** backup circuit is powered by the inverter directly

For normal operation, the switch should be set to 2. On 2, if the grid fails the backup circuit will remain energized by the inverter with the available PV and battery power. The OFF setting is to turn off AC power to the backup circuit.

### 4.9.3 Backup Power

You will need to speak with the homeowner to understand why they are installing a battery. You will also need to determine how much power they consume, how much power their PV generates, how much storage power they have, and which loads they want to have backed up in the event of a power outage (grid failure). If the homeowner says that they want mostly everything backed up, this would be considered **whole-home backup**. If they say they are willing to live with just a few key things such as the fridge, lights, and outlets, this would be partial-home backup

Whether or not large loads such as air conditioners, pumps, and EV chargers can be backed up depends on how much available power there will be on average from PV, batteries, and generator (if there is one). It is recommended to calculate this carefully using historical consumption data obtained from the homeowner's electricity bills and inspecting the existing service panel breakers. Also, be sure to determine how much average daily PV power will be available throughout the year.



#### Backup without PV and AC-Coupling:

A battery is required for backup power. If only PV is installed, this inverter is not able provide backup power when the grid is down. However, the inverter is able to support the backup panel with a battery only and no PV. The inverter with a battery can be AC-coupled to a system without directly connecting any PV to the inverter.



# 4. Installation

Depending on the battery, the S6 hybrid can have anywhere from 10kWh to 60kWh of stored power to provide in backup mode or for time-of-use. It is recommended to determine how much average PV power will be available and what average power consumption is to understand how long the battery will last in the event of a grid outage. The battery discharge power can be limited to ensure the battery drains more slowly. If the backup power demanded exceeds what is available, the inverter will display an alarm code and will shut down for a few minutes.

In the figures below are two different system designs. The S6 hybrid will be able work in parallel with other S6 hybrids units by Summer 2023. The service panel sizes shown in the figures are just examples. Panel sizes may vary, please abide by NEC code when designing the system. The main service panel breaker may need to be derated. An inverter combiner box may be added if necessary.

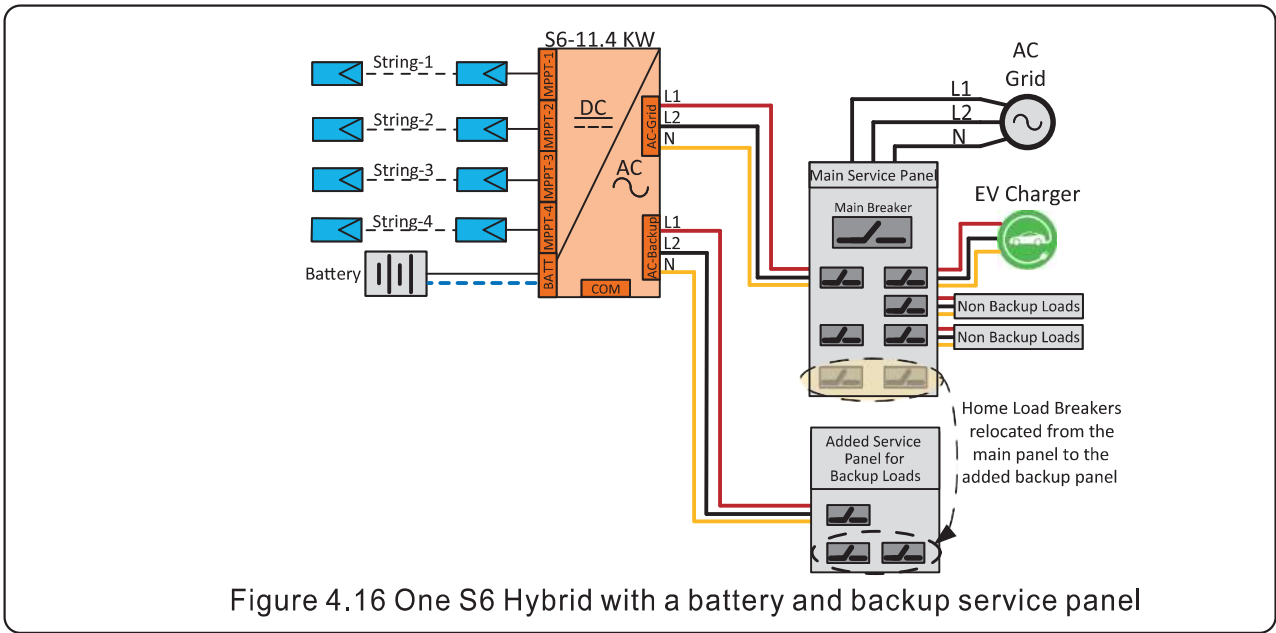

Figure 4.16 One S6 Hybrid with a battery and backup service panel

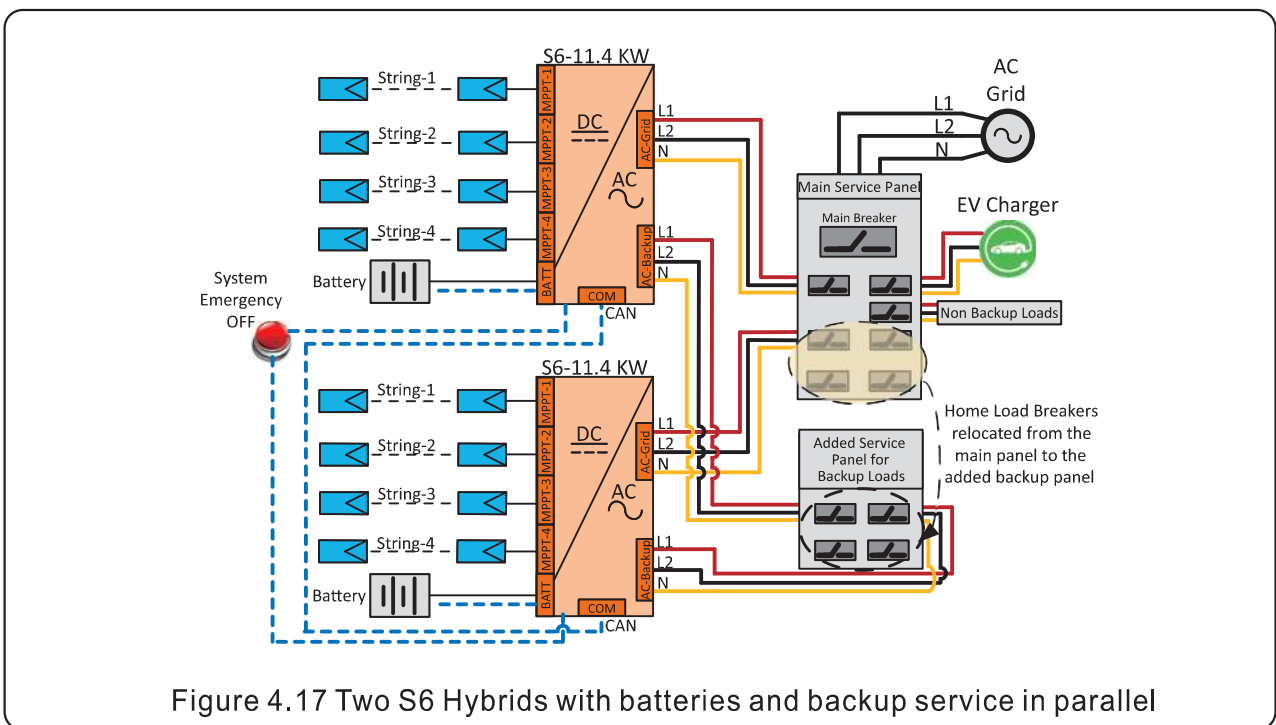

Figure 4.17 Two S6 Hybrids with batteries and backup service in parallel

# 4. Installation

## 4.9.4 Installing the AC cables



### **DANGER:**

Before installing the AC cables, be sure that the OCPDs (breakers) are turned off. Use a multimeter to verify that the AC voltages are 0Vac before proceeding.

### **Steps for installing the grid and backup AC cables**

1. Bring the AC cables for the backup loads panel (backup) and the main service panel (grid) into the inverter wire box. The backup loads panel should not be directly connected to the main service panel.
2. Strip ½ inch of insulation from the ends of each cable
3. Insert a technician screwdriver into the small hole above the wire terminal
4. Push in with the screwdriver and insert the wire into the terminal
5. Release the screwdriver and the terminal clamp will bite down on the wire
6. Give the wire a gentle tug test to ensure it is tight
7. If the wire feels loose, repeat steps 3-6
8. Connect the other ends of the AC cables in the main service panel to a breaker and neutral bus
9. Connect the other ends of the AC cables in the backup service panel to the panel lugs or to a breaker
10. Keep the breakers and AC bypass switch OFF for now, turn them on when doing commissioning.

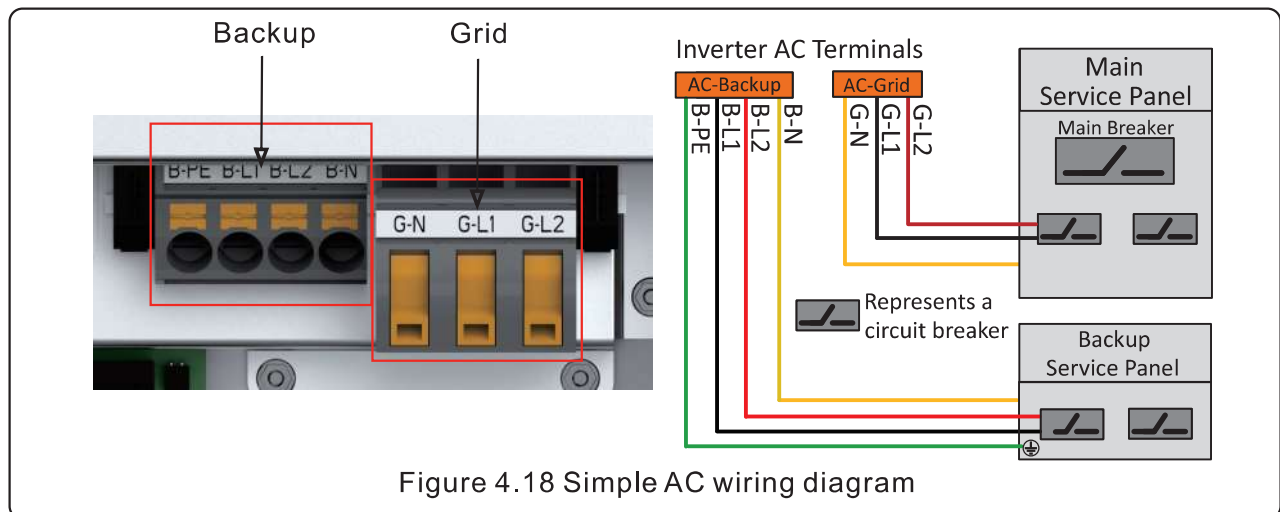

## 4.9.5 Steps for Setting up the Backup Service Panel

1. Once you have determined which breakers supply power to the things that are to be backed up, mark the breakers so that you will be able to identify them once the panel cover is off.
2. Shut off power to the house so that it is safe to work inside of the main panel (or subpanel).
3. Remove the panel cover, use a multimeter to verify that the panel is deenergized.
4. Turn off the breakers that are to be relocated, remove the wires from them and then cap off the wires for now. Remove the breakers and then install them into the backup loads panel.
5. Run separate wires from the main panel (or subpanel) to the backup loads panel. You will need to run one wire for each breaker that you are relocating.
6. In the main panel, connect the cables that you ran to the backup loads panel to the circuit cables that you capped off earlier. This can be done with wire nuts or something similar.
7. In the backup panel, terminate the wires in the breakers that you moved from the main panel.
8. Be sure to label the breakers in the backup loads panel so that they can be identified.

# 4. Installation

## 4.10 Inverter Communication

### 4.10.1 Communication Terminals Overview

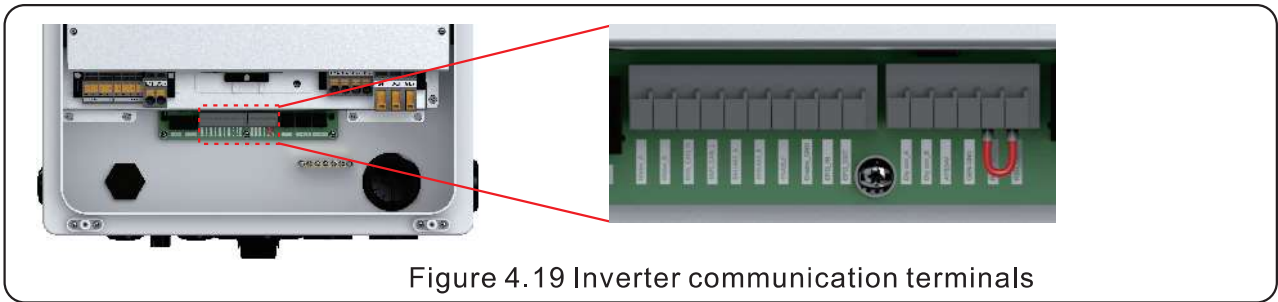

Figure 4.19 Inverter communication terminals

The inverter communication terminals consist of 16 ports.

From left to right, the chart below explains what they all are and are for.

NO.	Port	Function	Acceptable Wire Size Range
1	Meter_A	Used for RS485 communication between the inverter and the external energy meter. This is required in order to have full functionality of the hybrid inverter.	22-16 AWG
2	Meter_B		
3	BMS_CAN_H	Used for CAN communication between the inverter and a compatible battery.	
4	BMS_CAN_L		
5	BMS485_A	Used for RS485 communication with compatible batteries that use it and not CAN.	
6	BMS485_B		
7	ENABLE		
8	Enable_GND		
9	EPO_IN	Emergency Power Off signal	
10	EPO_OUT		
11	Dry con_A	Dry contact for generator connection (Reserved)	
12	Dry con_B		
13	ATS24V	For Supplementary ATS connection (Reserved)	
14	GEN GND		
15	RSD_IN	For each side of the external rapid shutdown initiation switch (optional)	
16	RSD_OUT		
17	Parallel_IN	For parallel connection (Reserved)	RJ45 Port
18	Parallel_OUT		
19	DRM	Not Applicable	
20	LOGGER	For inverter monitoring (logger) connection on SolisCloud	USB Port
21	COM1/COM2 & RSD	Conduit knockouts for cable glands and communication wires	Conduit
22	ANTENNA	For extending the bluetooth signal	Cable gland

Table 4.5 Inverter communication terminals explained

# 4. Installation



**Note:**

COM1 and COM2 conduit knockouts are for 1/2 inch cable glands or conduit fittings. Please be sure to not run com cables in the same conduit as high voltage conductors. Doing this could cause communication issues.

**Steps for installing the communication wires:**



1. Strip 1/4 inch off the end of the com wire
2. Use a technician screwdriver to press the block on the top of the terminal
3. Insert the stripped com wire into the terminal
4. Remove the screwdriver and the terminal will clamp down on the wire
5. Give the cable a gentle tug to ensure that it is firmly secured. If it is not, repeat steps 2-5.

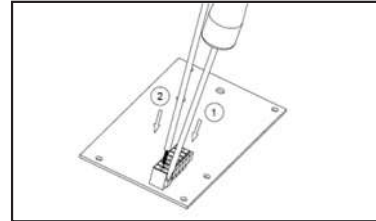

## 4.10.2 External Energy Meter Communication

The Acrel AGF-AE-D energy meter comes with the inverter. Please use the diagram below to connect the meter communication wires to the Meter\_A and Meter\_B pins on the inverter communication terminal block.

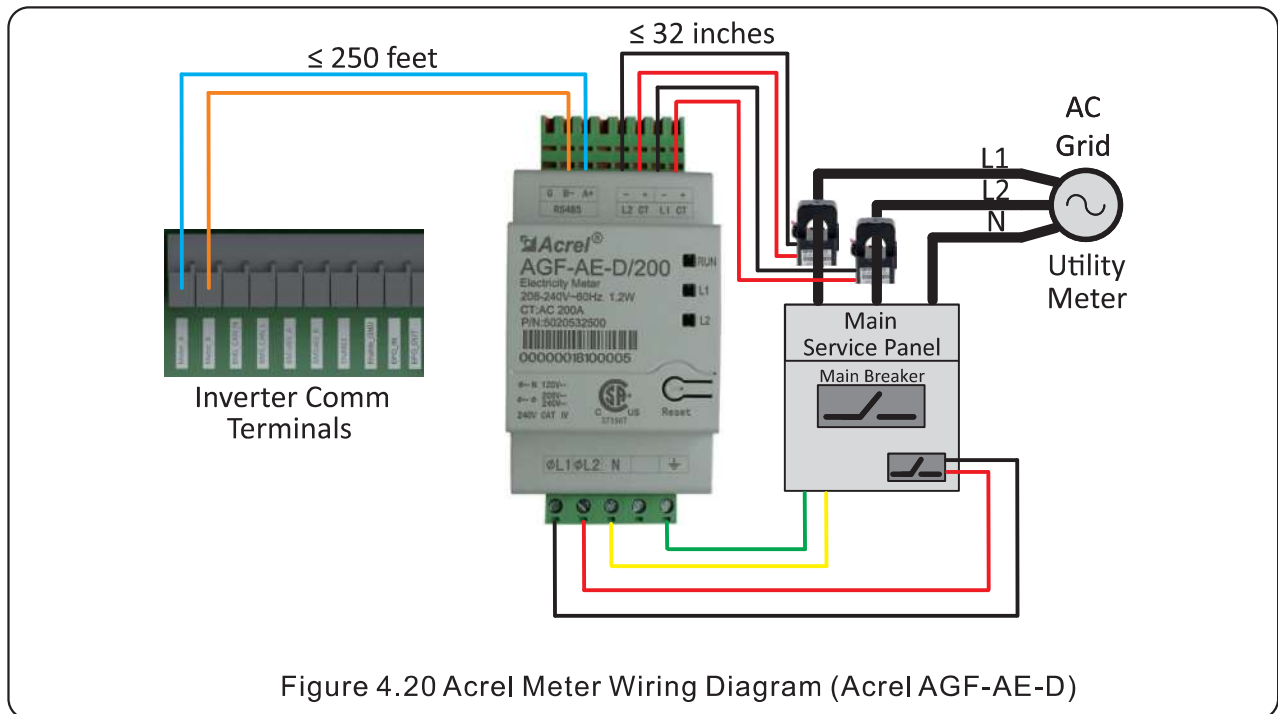

Figure 4.20 Acrel Meter Wiring Diagram (Acrel AGF-AE-D)

The Acrel meter must be installed in order to have a fully-functioning system. If the meter is not installed, key functions such as export power control and default energy storage modes will not be available. It is possible for the system to function without the meter. In the meter-select menu choose “No Meter”.

# 4. Installation

## 4.10.3 Battery Communication

- **CAN Communication** (BYD, Soluna, & Pylontech batteries): Connect a CAT5 cable to the battery CAN port and run the cable to the inverter. Split the cable at the inverter end, then connect the blue wire to BMS\_CAN\_H and the blue-white wire to BMS\_CAN\_L
- **RS485 Communication** (LG batteries): Run a CAT5 cable between the battery and the inverter. Split the cable at both ends and then use the diagram in Figure 4.22 to connect the four wires on both the battery and inverter ends.

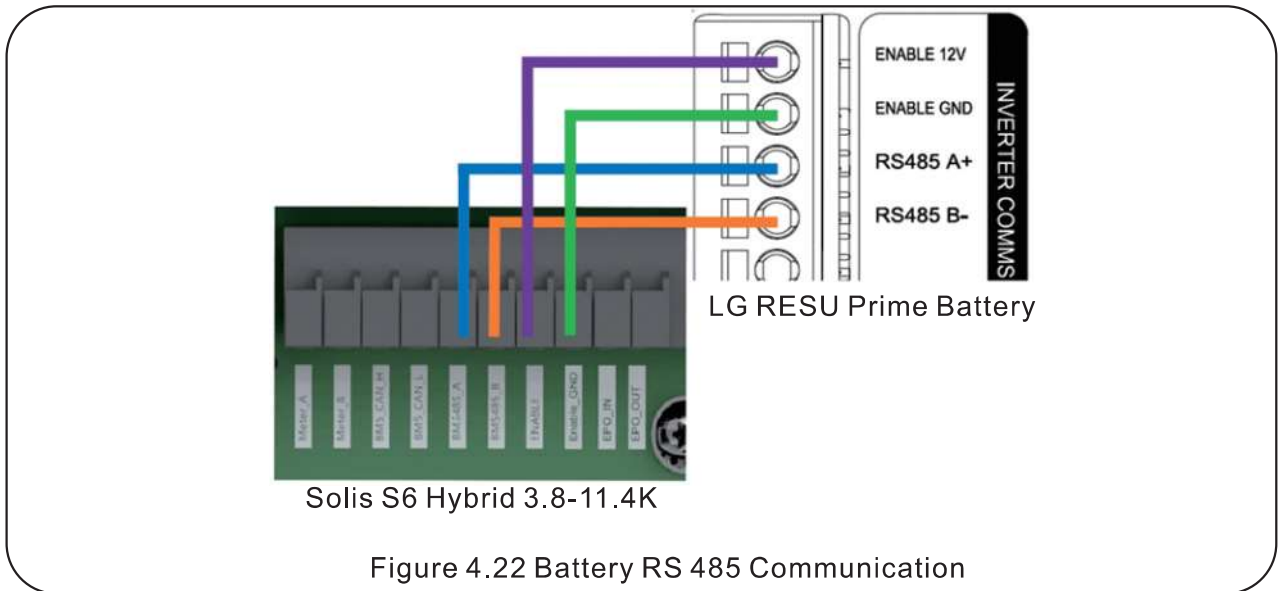
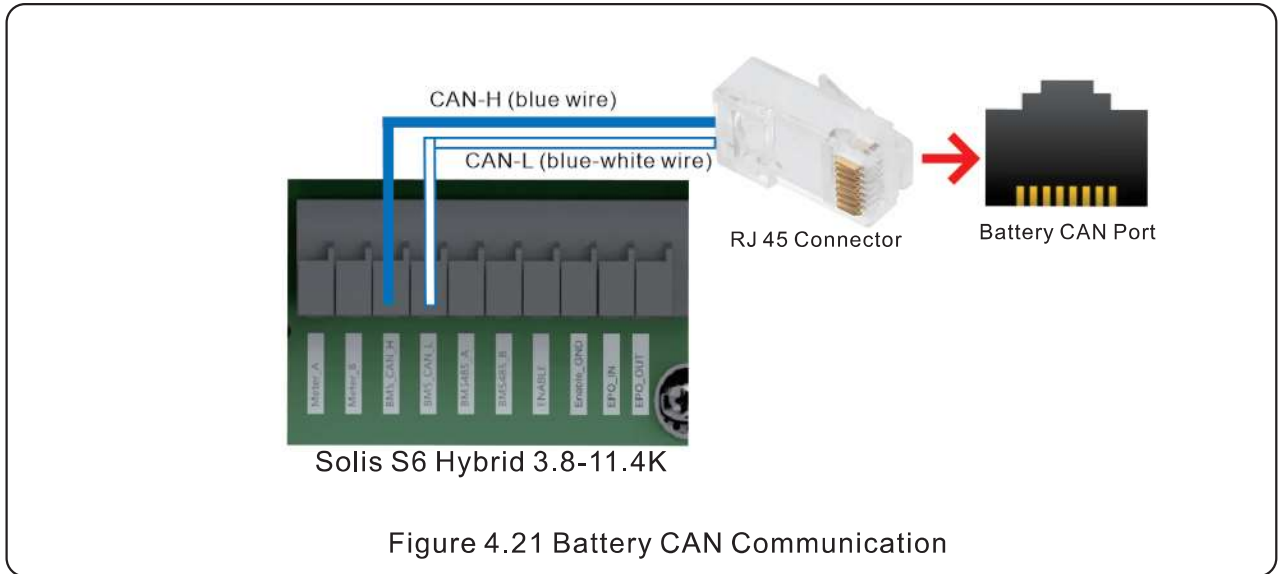

**Note:**

Some alarm codes are being relayed from the battery. These alarms are caused by an issue with the battery itself. The troubleshooting section of this manual explains how to diagnose and treat each alarm. If the alarm says the battery is having a malfunction, please contact the battery manufacturer.

# 4. Installation

## 4.10.4 Solis Data Logger Installation for Remote Monitoring

The inverter can be remotely monitored if a Solis data logger is installed. The USB “COM” port at the bottom of the inverter can connect to various kinds of Solis data loggers which allows for remote monitoring of the system on Soliscloud platform. To install a Solis data logger, please refer to corresponding user manual for that Solis data logger. The logger plugs into the COM port and then can be added to SolisCloud. The Solis data loggers are optional and they can be purchased separately. A dust cover is provided with the inverter in case a Solis logger is not used.



**NOTE:**

The USB COM port only allows a single data logger to be connected. Each Solis logger can support up to 10 inverters daisy-chained with RS 485.

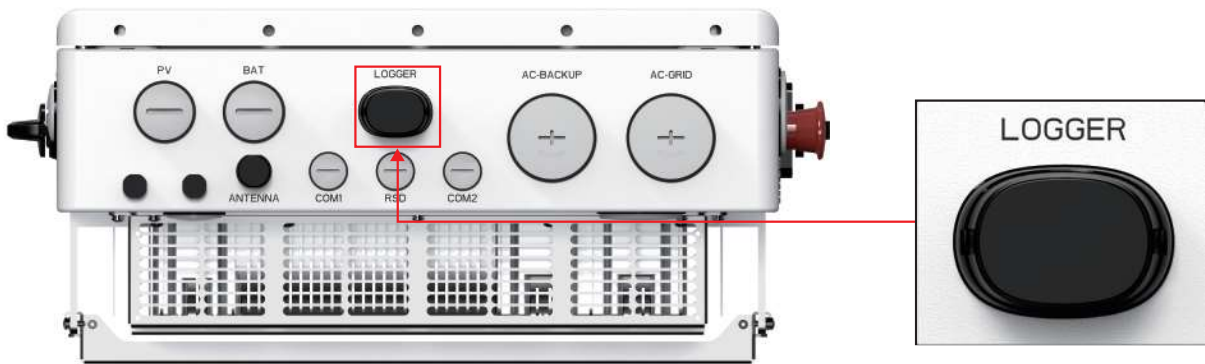

Figure 4.22 Solis Data Logger

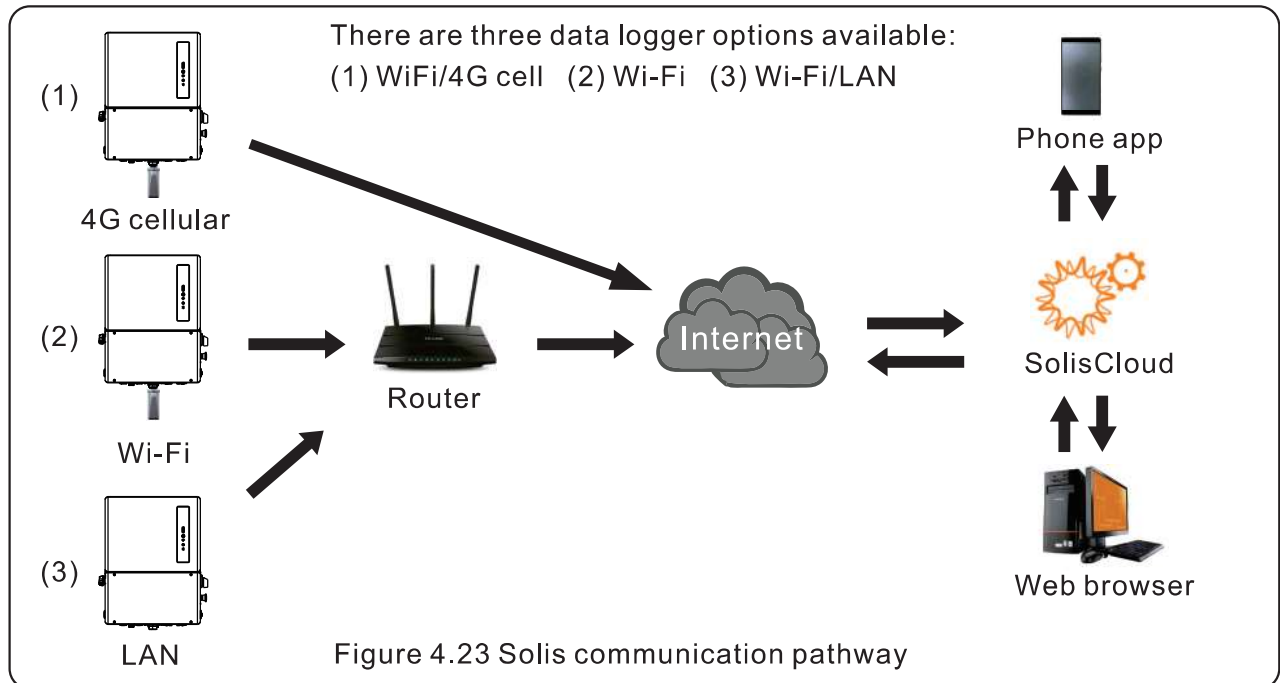

Figure 4.23 Solis communication pathway



# 5. Commissioning

---

## 5.1 Pre-Commissioning Steps

- Make sure that no high voltage conductors are energized.
- Check all conduit and cable connection points to ensure they are tight.
- Verify that all system components have adequate space for ventilation.
- Follow each cable to ensure that they are all terminated in the proper places.
- Ensure that all warning signs and labels are affixed on the system equipment.
- Verify that the inverter is secured to the wall and is not loose or wobbly.
- Prepare a multimeter that can do both AC and DC amps
- Have an Android or Apple mobile phone with Bluetooth capability
- Install the Soliscloud app on the mobile phone and register a new account.
- There are three ways to download and install the latest app:
  1. You can visit **www.soliscloud.com**
  2. You can search “**Soliscloud**” in Google Play or App Store.
  3. You can scan this QR code to download **Soliscloud**.



## 5.2 Commissioning Procedure

**Step 1:** With the DC switch off, energize the PV strings and then measure DC voltage of the PV strings to verify that the voltage and polarity are correct. Turn on the battery and check the battery voltage and polarity as well. If RSD is being used, the PV strings will be at safety voltage (~0.6-0.6Vdc per module in the string).

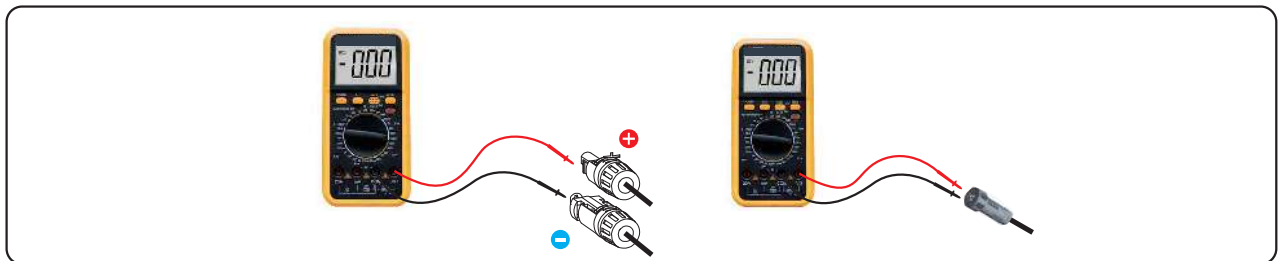

**Step 2:** Turn on the OCPD for the system and then measure the AC voltages line to line and line to neutral. The backup side of the system will be off until commissioning is complete. Turn the OCPD back off for now.

**Step 3:** Turn the DC switch on and then the OCPD (AC breaker) for the system. If you are using rapid shutdown, the voltage should increase after a few seconds. If it does not, give the rapid shutdown initiation switch a clockwise turn so that it pops out.

# 5. Commissioning

**Step 4:** Turn your phone Bluetooth on and then open the SolisCloud app. Go to “Me”, then tap “Tool”, then “Local Operation”, and then tap ”Connect with Bluetooth”.

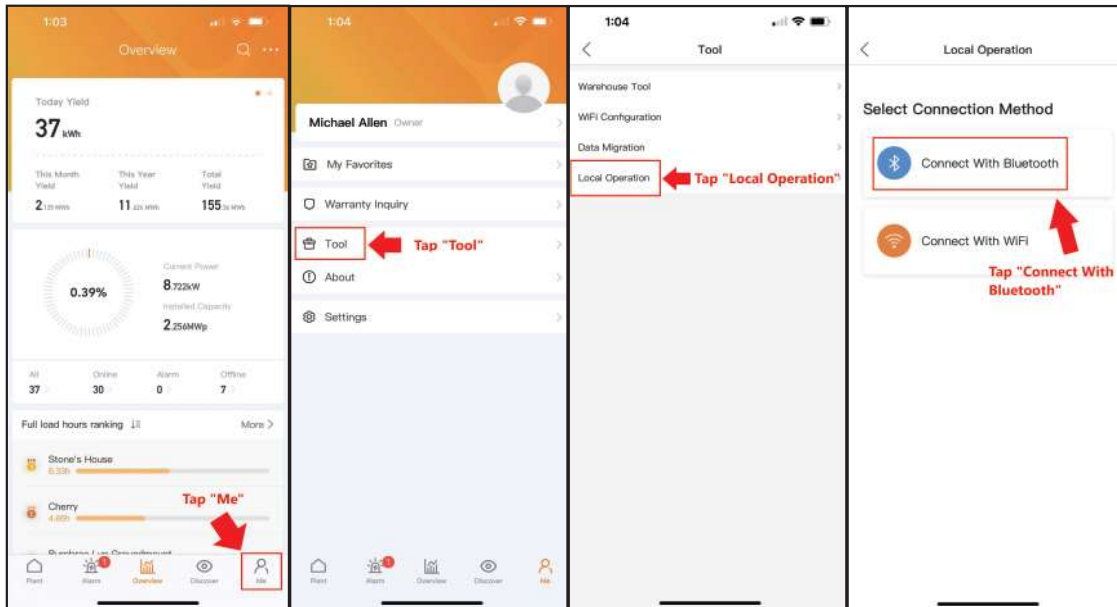

Tap the arrow to display nearby Bluetooth devices. Then tap BR2262e-S (note: if this device does not appear, be sure the inverter is at least getting start-up DC voltage). The next screen will prompt you to create a six-character password. The password must be exactly six characters. Once you set the password, tap “Set Enable”. You should then be given the message “Connection succeeded’ and then brought to the main interface page.

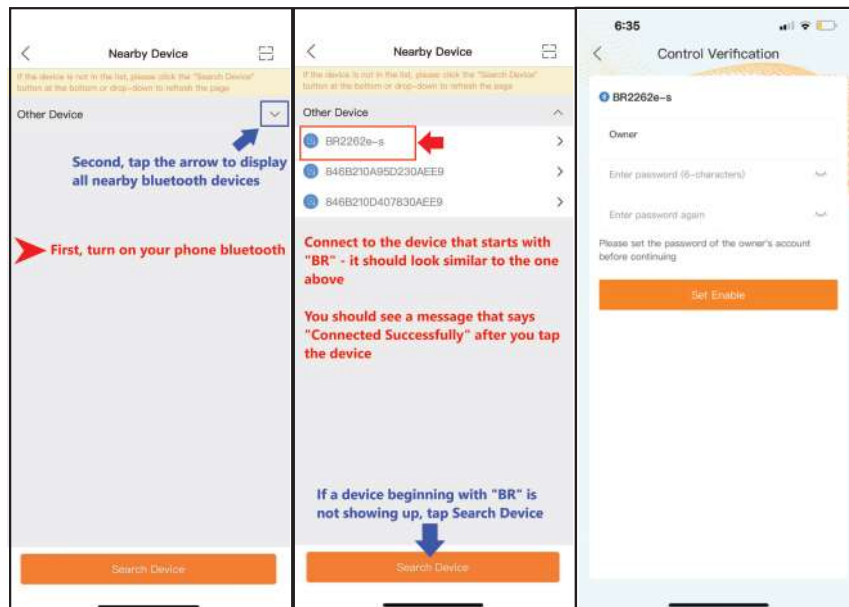

**NOTE:**

It is highly recommended to write down the password on paper and leave it inside of the inverter wire box. This is so that the password never gets lost or forgotten and can be easily accessed by other technicians.



# 5. Commissioning

**Step 5:** If this is the first time the inverter has been commissioned, you will need to first go through the Quick Settings. Once this has been done, these settings can be changed later.

A. Inverter Time: Set the Inverter Time and date. It may be easier to tap the slider next to “Follow Phone Time”. Then tap Next in the top right corner. This will set the inverter to match your phone.

B. Battery Model: Now select the battery model connected to the inverter. This choice must be based on the battery model that is actually connected to the inverter. If there is no battery connected for the moment, select “No Battery” to avoid potential alarms codes.

C. Meter Setting: Set both the Meter Type and the Meter Location. For US installations, this will be “Acrel 1P Meter” for the type and “Meter in Grid” for the location.

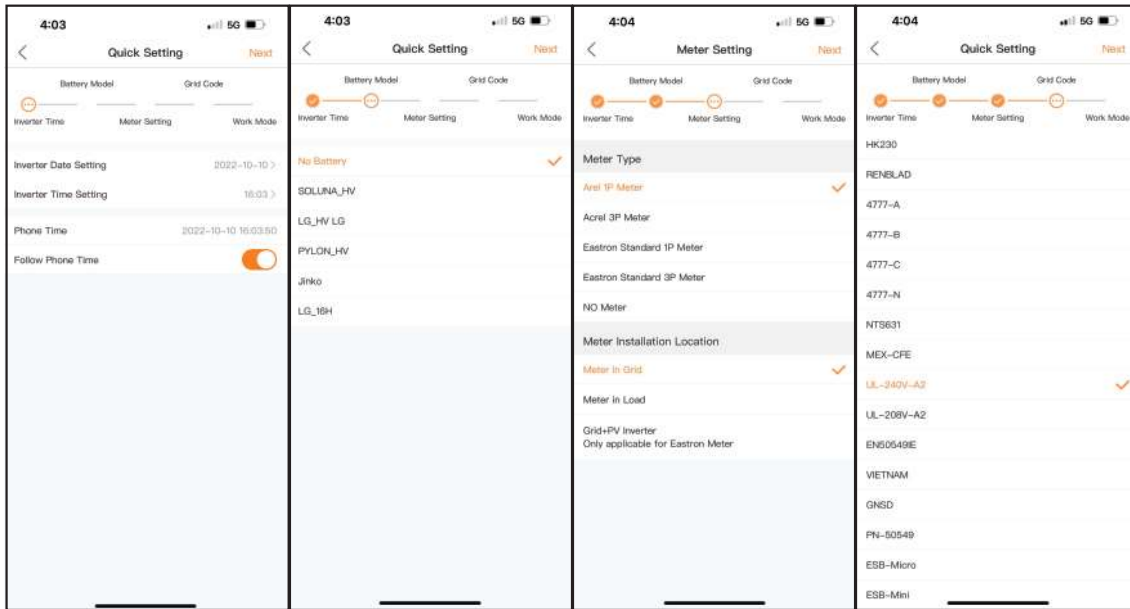

D. Grid Code: Systems in the US should either be on **UL-240V-A2**, **R21P3-24A** (CA Rule 21), or **ISONE-24A**. The default US standard is UL-240V-A2. Check with your local authority having jurisdiction (AHJ) to determine which grid code the inverter should be set to. If your AHJ requires Rule 21, then the code you select should be R21P3-24A. If your state abides by ISO New England standards, then select the ISONE-24A code. If your AHJ does not require Rule 21 or ISO New England standards, then UL-240V-A2 will be sufficient.



**Note:** All US grid codes are compliant to the IEEE 1547-2018 standards. This inverter is certified to UL 1741 SA and UL 1741 SB.

# 5. Commissioning

E. Work Mode: This is the energy storage operating mode. All four modes first priority is to use the available PV power to support the home loads. The different modes determine what the second priority, or use of the excess PV power, will be. Select the desired mode, then tap the slider switch to turn the mode on. The switch will appear orange if it is enabled.

**Self-Use mode** stores the excess PV power into the battery. If the battery is charged, or there is no battery, the excess PV power will be exported (sold) back to the utility company. If the system is set to not export any power, then the inverter will curtail the PV power (derate the inverter output power).

**Feed in Priority mode** will ensure that the system exports any excess PV power after the home loads are supplied. If the export power quota has been met, then the remaining PV power will be stored in the battery. This mode should not be used if export power is going to be set to zero.

**Backup Mode** can be enabled or disabled independently of the first two modes. What this mode does is ensure that the battery does not drain past the Reserve SOC (state-of-charge) percentage. The battery will cycle between 100% and the Reserve SOC, so if grid power is lost, the battery will have the Reserve SOC at the very least to carry the home through the outage.

**Off-grid Mode** is only to be used by systems that are not electrically connected to the grid at all. This mode is like Self-Use mode, but the PV power will be curtailed if the battery is charged and the home load demand is lower than the amount of available PV power.

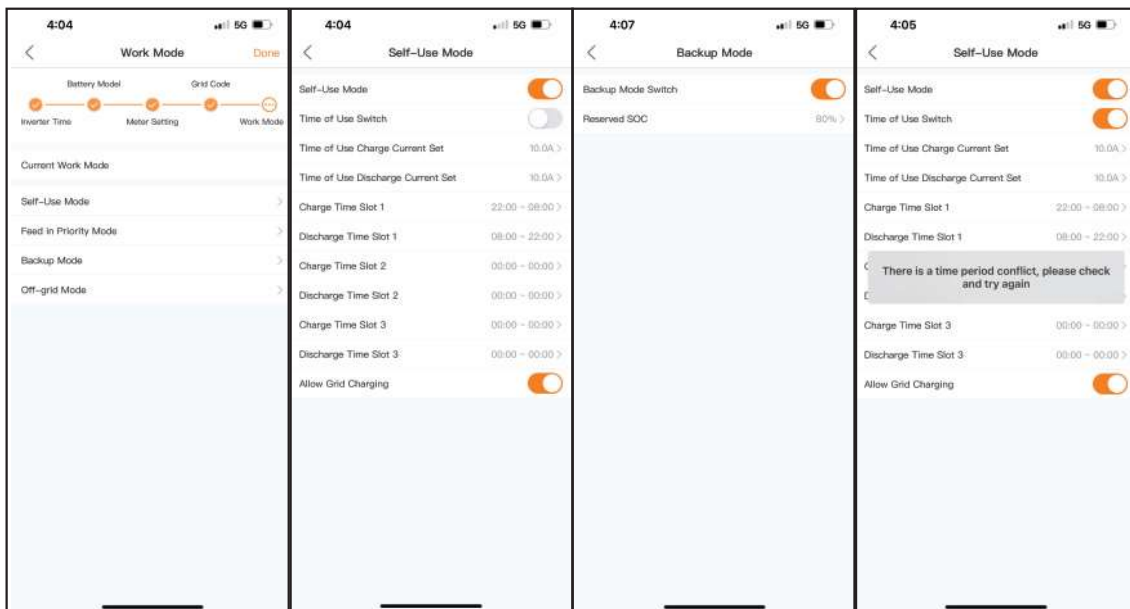

**Time of Use Switch** is for customizing when the battery is allowed to charge and discharge power and at what rate, established by a current (amperage) setting. If this slider switch is turned on, the inverter will only use this schedule to determine when to charge and discharge the battery. If **Allow Grid Charging** is turned on, the inverter will use grid power to charge the battery only under two circumstances: (1) the battery drains to the Force Charge SOC and (2) Time of Use is enabled and there is not enough available PV power during the charge window to meet the current rate that is established.

**Time of Use is for manual control of the battery charging/discharging. If Time of Use is turned off, charging/discharging is automatically regulated by the inverter.**

# 5. Commissioning

Step 6: After the initial settings are done, you will be taken to the homepage where you will see different icons. At the bottom of the page are four submenus: Home, Info, Settings, and More. The Info page breaks down into four categories: Inverter, Battery, Grid, and Load.

**Inverter:** inverter power production history, PV voltages and currents, inverter information (serial number, model number, and firmware version), grid code, and alarm code history

**Battery:** battery model and status, battery voltage and current

**Grid:** power imported and exported, AC grid voltage, frequency, and amperage

**Load:** power being consumed by the home loads and backup loads

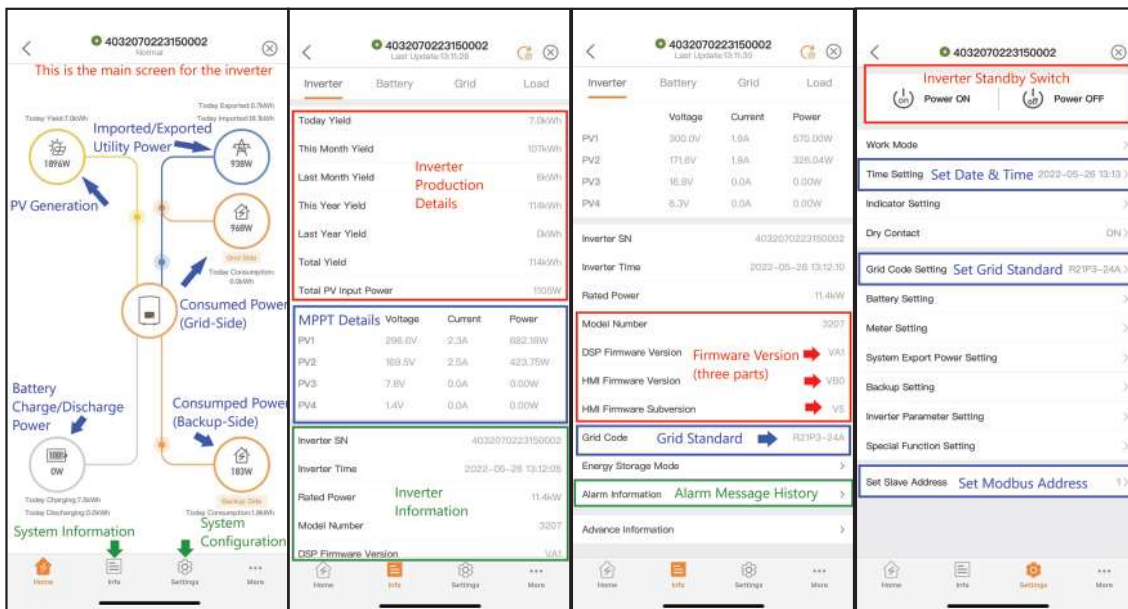

There are two additional settings which need to be configured in order to complete the inverter commissioning. Both of these settings can be found within the Settings submenu.

**System Export Power:** This is the amount of power the inverter is permitted to export (or sell) back to the utility company. If you do not want the system exporting power, this setting must be configured.

**Backup Power:** This is the power designated to the backup loads panel in the event of a grid power loss.

# 5. Commissioning

Step 7: The final step of commissioning is to configure the System Export Power setting and also the Backup Setting, for the backup power. Tap System Export Power Setting, then tap the slider switch to turn this mode on. Tap System Export Power Limit Value and then enter in the desired amount of power that can be exported to the grid.

**Maximum Export:** This value should match the nameplate rating (or model) of the inverter.

Example: if the model is S6-EH1P11.4K-H-US, enter 11400W

**Zero Export:** This value should be entered as 0W so that the system will not export any excess PV-generated power.

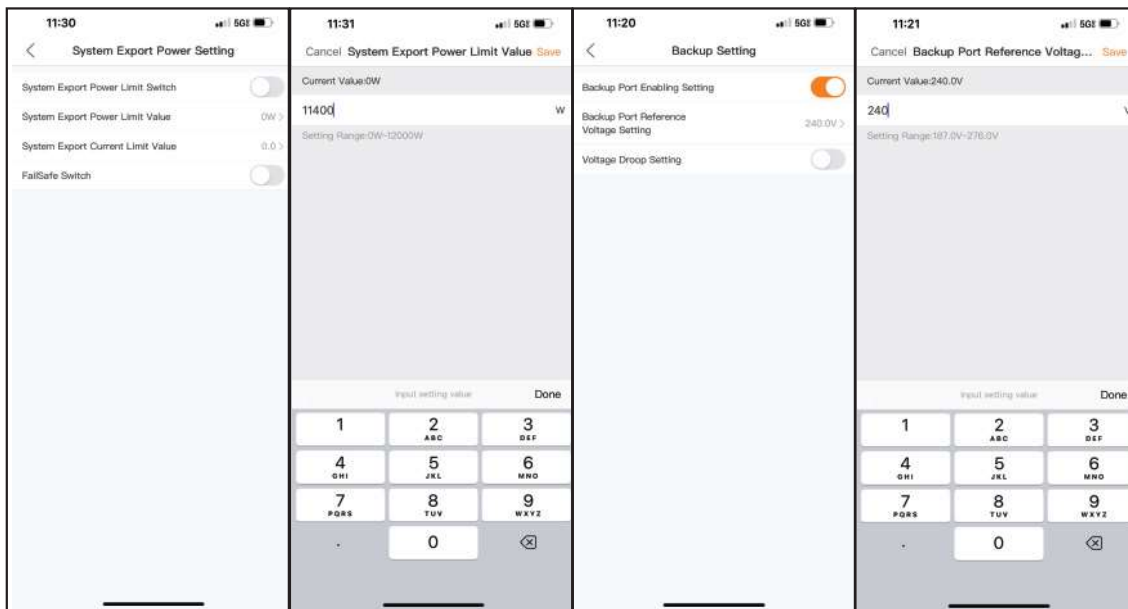

Enabling the FailSafe Switch will mean that the inverter will not produce any PV power if the inverter loses communication with the Acrel energy meter.

Tap Backup Setting and then tap Backup Port Reference Voltage Setting. Enter 240 into the field and then tap Save in the top right corner. Lastly, tap the Backup Port Enabling Setting slider switch to turn the backup side of the inverter on

**The inverter commissioning process has now been completed. It is recommended to monitor the system closely over the next week to ensure that everything is working as it should. Please refer to the Solis data logger manual for assistance with registering a new plant on SolisCloud.**

**Note: A full factory reset can be done, if needed. This function can be found in the Special Setting Function menu within the Settings tab using the app Bluetooth tool.**

# 6. Troubleshooting

---

If the inverter is having an issue, it will show it in one of the following ways: (1) the Inverter (circle) LED indicator light will flash orange. (2) the inverter status will be an alarm code (3) an alarm code will display on SolisCloud or (4) the inverter will simply be off. The next several pages explain how to troubleshoot each alarm code. If it is suspected that the issue is coming from the DC side of the system, it is recommended to turn the inverter off so that the PV strings can be more safely tested.

## Inverter Shutdown Procedure

Step 1. Turn off the AC breaker or AC disconnect switch to disable AC power to the inverter

Step 2. Turn off the DC switch of the inverter and push in the Rapid Shutdown Initiation Switch

Step 3. Turn off the battery breaker

Step 4. Use a multimeter to verify that the battery and AC voltages are 0V

Solis S6 hybrid inverter does not require any regular maintenance. However, keeping the heatsink clean will ensure the inverter is able to dissipate heat, increasing the life span of the inverter. Any grease smudges on the inverter chassis can be cleaned off with soap and water.



**CAUTION:**

Do not touch the surface of the inverter it is operating. Some parts may be hot and could cause a minor burn. Turn off the inverter (refer to Section 6.2) and let it cool down before you do any maintenance or cleaning of it.

The LED status indicator lights can be cleaned with damp cloth if they are too dirty to be read.



**Note:**

Never use any solvents, abrasives, or corrosive materials to clean the inverter.

The inverter has been designed in accordance with international standards for safety and electromagnetic compatibility requirements. Before being shipped from the manufacturing center, the inverter is subjected to multiple tests to ensure operation reliability.

If you are not able to resolve the alarm code using the troubleshooting steps, or if the alarm code you are seeing is not listed, please contact Solis US Technical support. Use the Bluetooth tool, go to the Info page and then to the Inverter tab. Scroll down and tap Alarm History and then screen shot or write down the alarms as well as the dates and times the alarms were recorded.

Please also take note of the inverter model number, serial number, and internal transmitter type.

Solis US Technical Support Phone Number: +1(866)438-8408

Solis US Technical Support Email: [usservice@solisinverters.com](mailto:usservice@solisinverters.com)

## 6. Troubleshooting

Alarm Message	Failure description	Solution
ARC-FAULT	ARC detected in DC circuit	1. Check if there is an arc in the PV connection and restart inverter.
AFCI Check FAULT	AFCI module self check fault	1. Restart inverter or contact installer.
DCinj-FAULT	High DC injection current	1. Restart inverter or contact installer.
DSP-B-FAULT	Comm. failure between main and slave DSP	1. Restart inverter or contact installer.
DC-INTF	DC input overcurrent	1. Restart inverter. 2. Identify and remove the string related to the faulty MPPT. 3. Change power board.
G-IMP	High grid impedance	1. User design function allows the protection limit to be adjusted if it is allowed by electrical company.
GRID-INTF01/02	Grid interference	1. Restart inverter. 2. Change power board.
IGBT-OV-I	Over IGBT current	
IGFOL-F	Grid current tracking fail	1. Restart inverter or contact installer.
IG-AD	Grid current sampling fail	
lLeak-PRO 01/02/03/04	leakage current protection	1. Check AC and DC connection. 2. Check inverter inside cable connection.
INI-FAULT	Initialization system fault	1. Restart inverter or contact installer.
LCD show initializing all the time	Can not start-up	1. Check if the connectors on the main board or power board are secure. 2. Check if the DSP connection to the power board is secure.
NO-Battery	Unconnected battery	1. Ensure the battery is connected properly. 2. Verify the output battery voltage is correct.
No power	Inverter no power on LCD	1. Check PV input connections. 2. Check DC input voltage (single phase >120V, three phase >350V). 3. Check if PV+/- is reversed.
NO-GRID	No grid voltage	1. Check connections and grid switch. 2. Verify the grid voltage is correct on the AC Terminals inside the inverter wiring box.
OV-BUS	Over DC bus voltage	1. Check inverter inductor connection. 2. Check driver connection.



## 6. Troubleshooting

---

Alarm Message	Failure description	Solution
OV-DC01/02/03/04	Over DC voltage	1. Reduce the module number in series.
OV-DCA-I	DC input overcurrent	1. Restart inverter. 2. Identify and remove the string of the faulted MPPT. 3. Change power board.
OV-G-V01/02/03/04/05	Over grid voltage	1. Resistance of AC Cable is too high. Increase the gauge of grid cables. 2. Adjust the protection limit if it is permitted by electrical company.
OV-G-I	Over grid current	1. Restart inverter. 2. Change power board.
OV-G-F01/02	Over grid frequency	1. User design function allows the protection limit to be adjusted if it is permitted by electrical company.
OV-IgTr	AC side transient overcurrent	1. Restart inverter. 2. Return-factory repair.
OV-ILLC	LLC hardware overcurrent	
OV-VBackup	Backup overvoltage fault	
OV-TEM	Over Temperature	1. Check inverter surrounding ventilation. 2. Determine if there is direct sunlight on the inverter during hot weather.
OV-Vbatt1	The detection of battery overvoltage	1. Verify the protection point for over voltage is set correctly. 2. Restart inverter.
OV-Vbatt-H	Battery overvoltage hardware fault	1. Check if any part of the battery input circuit is tripped, ie. battery fuses, battery circuit breaker. 2. Restart inverter.
Over-Load	Backup overload fault	1. Check the load of Backup port is over rating output power or not. 2. Reduce the load of Backup port, then restart inverter.
PV ISO-PRO01/02	PV isolation protection	1. Remove all DC input, reconnect and restart inverter one by one. 2. Identify which string cause the fault and check the isolation of the string.
RelayChk-FAIL	Relay check fail	1. Restart inverter or contact installer.

## 6. Troubleshooting

Alarm Message	Failure description	Solution
UN-BUS01/02	Under DC bus voltage	1. Check inverter inductor connection. 2. Check driver connection.
UN-G-F01/02	Under grid frequency	1. Use user define function to adjust the protection limit if it's allowed by electrical company.
UN-G-V01/02	Under grid voltage	
12Power-FAULT	12V power supply fault	1. Restart inverter or contact installer.

Table 6.1 Fault message and description



**NOTE:**

If the inverter displays any alarm messages listed in Table 7.1, please turn off the inverter and wait for 5 minutes before restarting it. If the alarm persists, please contact Solis after-sales service +1(866)438-8408 or email [usservice@solisinverters.com](mailto:usservice@solisinverters.com)

If you have any technical problems with the hybrid system, please contact Solis after-sales service. We recommend gathering the following information before making contact in order to get a quicker resolution.

Item	Supplemental Information
Inverter serial number (SN)	Serial number can be found on the spec label
Inverter Firmware Version	A six character number that can be found in the information section of the inverter interface page - requires Bluetooth connection
Alarm history	Codes found in the Inverter section of the interface
DC voltages	Use a multimeter to measure the voltages
Detailed description of the problem	Frequency of the occurrence and any other relevant details about the issue
Battery serial number and Firmware version	Consult the battery product manual to determine how to collect this information
Is the system reporting to SolisCloud?	Yes/No - if yes, what is the site ID?
Take pictures showing all the cable connections in the system (Videos preferred)	If this is possible, it will help us to troubleshoot



# 7. Specifications

Technical Data	S6-EH1P3.8K-H-US	S6-EH1P5K-H-US
<b>Input DC (PV side)</b>		
Recommended max. PV power	6,080W	8,000W
Max. input voltage	600V	
Rated voltage	380V	
Start-up voltage	80V	
MPPT voltage range	80-550V	
Full load MPPT voltage range	140-450V	
Max. input current per string	16A	
Max. short circuit current per string	25.6A	
Number of MPPTs/Number of strings per MPPT	2/1	3/1
<b>Energy Storage</b>		
Battery type	Lithium-ion	
Battery voltage range	120 - 500V	
Maximum charge/discharge current	25A	
Battery Communication	CAN/RS485	
Number of batteries per inverter	See Battery Compatibility Sheet	
<b>AC Output (Grid)</b>		
Rated output power	3.8kW	5kW
Max. apparent output power	3.8kW	5kW
Rated output voltage	240 V/120 V	
Rated frequency	60 Hz	
Rated output current	15.8A	20.8A
Max. output current	15.8A	20.8A
THDi	<3%	
<b>AC Input (Grid)</b>		
Input voltage range	204-276V	
Max. input current	23.8A	31.2A
Frequency range	55-65 Hz	

## 7. Specifications

Technical Data	S6-EH1P3.8K-H-US	S6-EH1P5K-H-US
<b>AC Output (Backup and Off-grid)</b>		
Rated output power	3.8kW	5kW
Max. apparent output power	6.1 kVA, 10 sec	8 kVA, 10 sec
Back-up switch time	< 10 ms	
Phase Power	240V Split-Phase	
Rated output voltage(L1-L2)/(L1/L2-N)	240 V/120 V	
AC output voltage range	204-276 V	
Rated grid frequency	60 Hz	
Rated AC output current (continuous)	15.9A	20.8A
Max. output current for 10 seconds	25.4A	33.3A
Max. output current for 300 milliseconds	28.62A	37.44A
Max. allowable phase imbalance	100%	
Backup support configurations	Dedicated loads and whole-home	
Power Factor	> 0.99 (0.8 leading - 0.8 lagging)	
THDv(@linear load)	<3%	
<b>Efficiency</b>		
PV Max. efficiency	97.6%	
PV CEC efficiency	97.2%	
BAT charged by PV Max. efficiency	98.5%	
BAT charged/discharged to AC Max. efficiency	97.0%	
<b>Protection</b>		
Ground fault detection	Yes	
Residual (leakage) current detection	Yes	
Integrated AFCI (DC arc-fault protection)	Yes	
DC reverse-polarity protection	Yes (PV only)	
Rapid Shutdown NEC 2017	Integrated SunSpec-certified Transmitter	
Compatible Rapid Shutdown Receivers	See MLRSD compatibility sheet	
Protection class/Over voltage category	I/II	

# 7. Specifications

Technical Data	S6-EH1P3.8K-H-US	S6-EH1P5K-H-US
<b>General data</b>		
Dimensions(H/W/D)	25.5*19.2*9 in (647*488*228.5 mm)	
Weight	44.1 lbs (20 kg)	
Topology	Transformerless	
Operation temperature range	-25 ~ +60 °C / -31 ~ +140 °F	
Ingress protection	NEMA 4X(IP66)	
Noise emission (Typical)	< 30 dB (A)	
Cooling method	Natural convection	
Max. operating altitude	13120 ft (4000 m)	
Compliance	UL 1741 SB, UL 1741 SA, IEEE1547.1-2020, UL 1699B, UL 1998, FCC Part 15 Class B, California Rule 21, HECO Rule 14H (pending), NEC 690.12-2020, CAN/CSA C22.2107.1-1	
Generator support	Yes	
<b>Features</b>		
DC connection	1 in. knockouts for conduit (x2) on the side and bottom; Spring clamp terminals	
AC connection	2 in. knockouts for conduit (x3) on the side and bottom; Spring clamp terminals	
Interface	LED indicator lights, Bluetooth/Phone app	
Monitoring Platform	SolisCloud (modbus map and API sharing available upon request)	
Communication	RS485, Optional: Cellular, Wi-Fi, LAN	
Warranty	10 years standard (Extendable to 20 years)	

## 7. Specifications

Technical Data	S6-EH1P7.6K-H-US	S6-EH1P8K-H-US
<b>Input DC (PV side)</b>		
Recommended max. PV power	12160W	12800W
Max. input voltage	600V	
Rated voltage	380V	
Start-up voltage	80V	
MPPT voltage range	80-550V	
Full load MPPT voltage range	175-450V	185-450V
Max. input current per string	16A	
Max. short circuit current per string	25.6A	
Number of MPPTs/Number of strings per MPPT	4/1	
<b>Energy Storage</b>		
Battery type	Lithium-ion	
Battery voltage range	120 - 500V	
Maximum charge/discharge current	50A	
Battery Communication	CAN/RS485	
Number of batteries per inverter	See Battery Compatibility Sheet	
<b>AC Output (Grid)</b>		
Rated output power	7.6kW	8kW
Max. apparent output power	7.6kW	8kW
Rated output voltage	240 V/120 V	
Rated frequency	60 Hz	
Rated output current	31.7A	33.3A
Max. output current	31.7A	33.3A
THDi	<3%	
<b>AC Input (Grid)</b>		
Input voltage range	204-276V	
Max. input current	47.6A	49.9A
Frequency range	55-65 Hz	

# 7. Specifications

Technical Data	S6-EH1P7.6K-H-L-US	S6-EH1P8K-H-US
<b>AC Output (Backup and Off-grid)</b>		
Rated output power	7.6kW	8kW
Max. apparent output power	12.2 kVA, 10 sec	12.8 kVA, 10 sec
Back-up switch time	< 10 ms	
Phase Power	240V Split-Phase	
Rated output voltage(L1-L2)/(L1/L2-N)	240 V/120 V	
AC output voltage range	204-276 V	
Rated grid frequency	60 Hz	
Rated AC output current (continuous)	31.7A	33.3A
Max. output current for 10 seconds	50.7A	53.3A
Max. output current for 300 milliseconds	57.06A	59.94A
Max. allowable phase imbalance	100%	
Backup support configurations	Dedicated loads and whole-home	
Power Factor	>0.99 (0.8 leading - 0.8 lagging)	
THDv(@linear load)	<3%	
<b>Efficiency</b>		
PV Max. efficiency	97.6%	
PV CEC efficiency	97.2%	
BAT charged by PV Max. efficiency	98.5%	
BAT charged/discharged to AC Max. efficiency	97.0%	
<b>Protection</b>		
Ground fault detection	Yes	
Residual (leakage) current detection	Yes	
Integrated AFCI (DC arc-fault protection)	Yes	
DC reverse-polarity protection	Yes (PV only)	
Rapid Shutdown NEC 2017	Integrated SunSpec-certified Transmitter	
Compatible Rapid Shutdown Receivers	See MLRSD compatibility sheet	
Protection class/Over voltage category	I/II	

# 7. Specifications

Technical Data	S6-EH1P7.6K-H-L-US	S6-EH1P8K-H-US
<b>General data</b>		
Dimensions(H/W/D)	26.6*21.9*9.4 in (676*555*238.5 mm)	
Weight	81.1 lbs (36.8 kg)	
Topology	Transformerless	
Operation temperature range	-25 ~ +60 °C / -31 ~ +140 °F	
Ingress protection	NEMA 4X(IP66)	
Noise emission (Typical)	< 30 dB (A)	
Cooling method	Natural convection	
Max. operating altitude	13,120 ft (4000 m)	
Compliance	UL1741 SB, UL1741 SA, IEEE1547.1-2020, UL1699B, UL1998, FCC Part 15 Class B, California Rule 21, HECO Rule 14H (pending), NEC 690.12-2020, CAN/CSA C22.2107.1-1	
Generator support	Yes	
<b>Features</b>		
DC connection	1 in. knockouts for conduit (x2) on the side and bottom; Spring clamp terminals	
AC connection	2 in. knockouts for conduit (x3) on the side and bottom; Spring clamp terminals	
Interface	LED indicator lights, Bluetooth/Phone app	
Monitoring Platform	SolisCloud (modbus map and API sharing available upon request)	
Communication	RS485, Optional: Cellular, Wi-Fi, LAN	
Warranty	10 years standard (Extendable to 20 years)	

## 7. Specifications

Technical Data	S6-EH1P10K-H-US	S6-EH1P11.4K-H-US
<b>Input DC (PV side)</b>		
Recommended max. PV power	16,000W	18,240W
Max. input voltage	600V	
Rated voltage	380V	
Start-up voltage	80V	
MPPT voltage range	80-550V	
Full load MPPT voltage range	230-450V	245-450V
Max. input current per string	16A	
Max. short circuit current per string	25.6A	
Number of MPPTs/Number of strings per MPPT	4/1	
<b>Energy Storage</b>		
Battery type	Lithium-ion	
Battery voltage range	120 - 500V	
Maximum charge/discharge current	50A	
Battery Communication	CAN/RS485	
Number of batteries per inverter	See Battery Compatibility Sheet	
<b>AC Output (Grid)</b>		
Rated output power	10kW	11.4kW
Max. apparent output power	10kW	11.4kW
Rated output voltage	240 V/120 V	
Rated frequency	60 Hz	
Rated output current	41.7A	47.5A
Max. output current	41.7A	47.5A
THDi	<3%	
<b>AC Input (Grid)</b>		
Input voltage range	204-276V	
Max. input current	62.6A	71.3A
Frequency range	55-65 Hz	

# 7. Specifications

Technical Data	S6-EH1P10K-H-US	S6-EH1P11.4K-H-US
<b>AC Output (Backup and Off-grid)</b>		
Rated output power	10kW	11.4kW
Max. apparent output power	16 kVA, 10 sec	18.2 kVA, 10 sec
Back-up switch time	< 10 ms	
Phase Power	240V Split-Phase	
Rated AC output voltage	240 V/120 V	
AC output voltage range	204-276 V	
Rated frequency	60 Hz	
Rated AC output current (continuous)	41.7A	47.5A
Max. output current for 10 seconds	66.7A	76A
Max. output current for 300 milliseconds	75.06A	85.5A
Max. allowable phase imbalance	100%	
Backup support configurations	Dedicated loads and whole-home	
Power Factor	> 0.99 (0.8 leading - 0.8 lagging)	
THDv(@linear load)	<3%	
<b>Efficiency</b>		
PV Max. efficiency	97.6%	
PV CEC efficiency	97.2%	
BAT charged by PV Max. efficiency	98.5%	
BAT charged/discharged to AC Max. efficiency	97.0%	
<b>Protection</b>		
Ground fault detection	Yes	
Residual (leakage) current detection	Yes	
Integrated AFCI (DC arc-fault protection)	Yes	
DC reverse-polarity protection	Yes (PV only)	
Rapid Shutdown NEC 2017	Integrated SunSpec-certified Transmitter	
Compatible Rapid Shutdown Receivers	See MLRSD compatibility sheet	
Protection class/Over voltage category	I/II	



# 7. Specifications

Technical Data	S6-EH1P10K-H-US	S6-EH1P11.4K-H-US
<b>General data</b>		
Dimensions(H/W/D)	26.6*21.9*9.4 in (676*555*238.5 mm)	
Weight	81.1 lbs (38.6 kg)	
Topology	Transformerless	
Operation temperature range	-25 ~ +60 °C / -31 ~ +140 °F	
Ingress protection	NEMA 4X (Ip66)	
Noise emission (Typical)	< 30 dB (A)	
Cooling method	Natural convection	
Max.operation altitude	13,120 ft (4000 m)	
Compliance	UL1741 SB, UL1741 SA, IEEE1547.1-2020, UL1699B, UL1998, FCC Part15 Class B, California Rule 21, HECO Rule 14H (pending), NEC 690.12-2020,CAN/CSA C22.2107.1-1	
Generator support	Yes; up to 25 kW	
<b>Features</b>		
DC connection	1 in. knockouts for conduit (x2) on the side and bottom; Spring clamp terminals	
AC connection	2 in. knockouts for conduit (x3) on the side and bottom; Spring clamp terminals	
Interface	LED indicator lights, Bluetooth/Phone app	
Monitoring Platform	SolisCloud (modbus map and API sharing available upon request)	
Communication	RS485, Optional: Cellular, Wi-Fi, LAN	
Warranty	10 years standard (Extendable to 20 years)	

# 8. Appendix

## 8.1 Single Line Diagram 1: One hybrid inverter

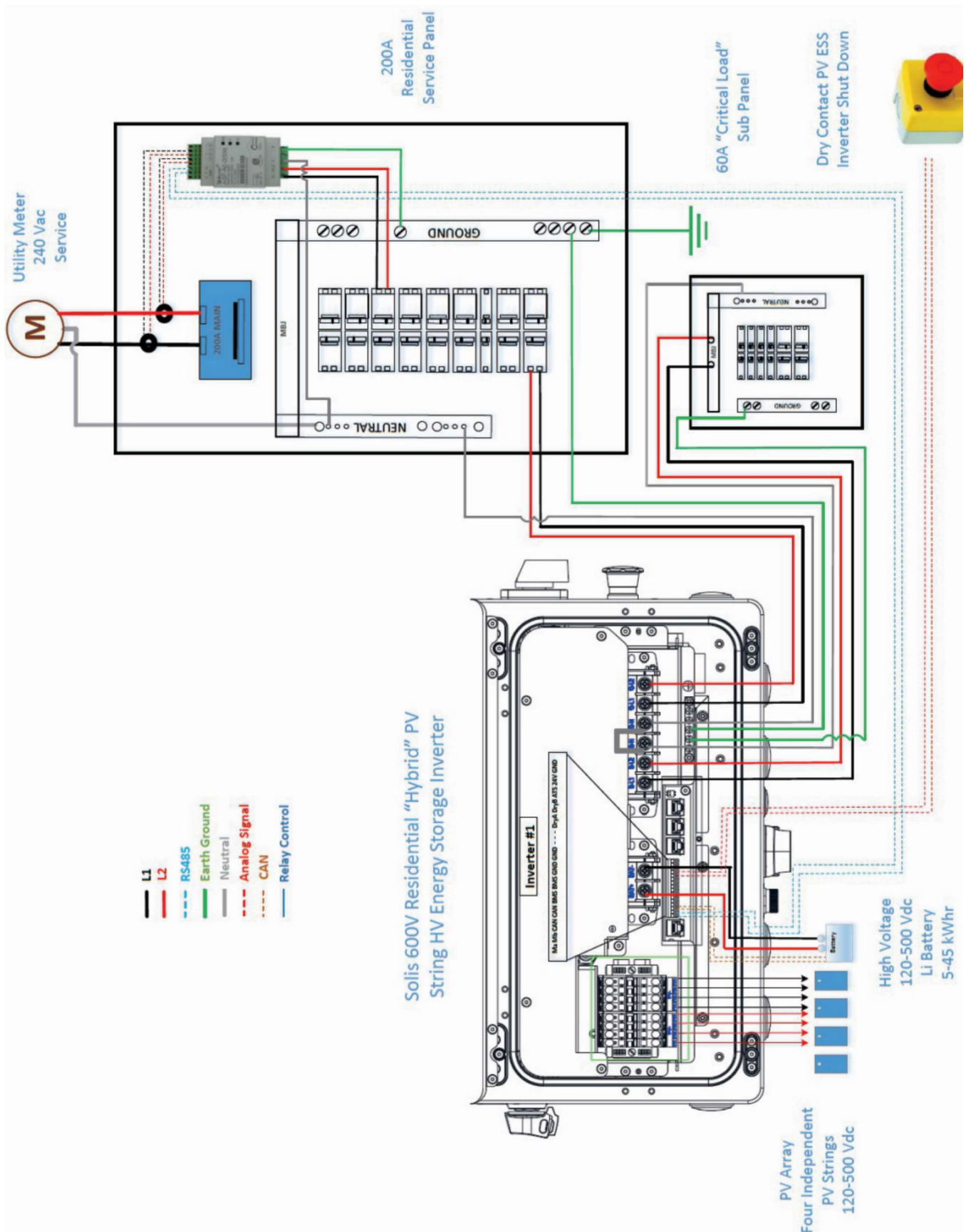

# 8. Appendix

## 8.1 Single Line Diagram 2: Two hybrid inverters in parallel

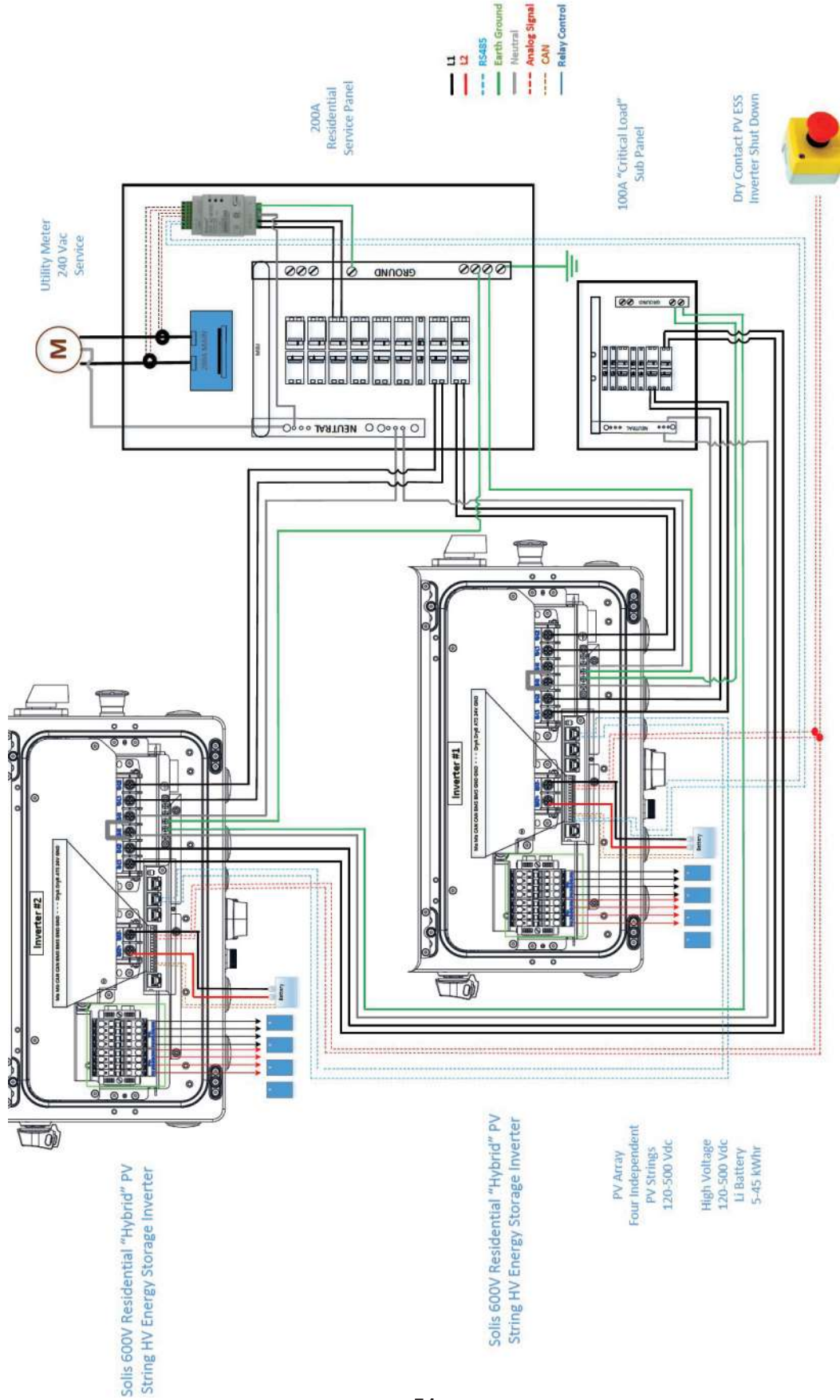

# 8. Appendix

---

## 8.2 FAQs

**Q1: How many batteries can be connected to a single S6 hybrid inverter?**

A1: The inverter has one battery input. However, if the battery manufacturer offers a combiner box then you can put as many batteries on the inverter as the combiner box supports.

**Q2: Can I parallel multiple S6 hybrids together without a Solis Power Hub (MID)?**

A2: Yes, as long as your service panels can support the output current. The inverters can be connected together with RS485 and they will balance the load with each other.

**Q3: Is this a high or low voltage hybrid inverter, and what is the battery voltage range?**

A3: This is a high voltage hybrid inverter with a battery voltage range of 120-500Vdc

**Q4: Does the UL1741 SB certified version of the Solis S6 hybrid inverter support 208Vac grid connection?**

A4: Upon launch in late November 2022, it will not support 208Vac grid connection, only 240Vac. However, in Q3 2023 the inverter will be updated to support 208Vac grid.

**Q5: Am I able to do remote settings changes and firmware updates so I do not have to go to the site?**

A5: Yes, as long as the inverter has a Solis data logger installed and is registered on SolisCloud. The Solis Support team can do remote settings changes and firmware updates.

**Q6: What is the Solis Power Hub mentioned in the video and will that launch at the same time as the new S6 hybrid inverter?**

A6: The Solis Power Hub is a microgrid interconnection device (MID) that will be an optional accessory only required if you are looking to get whole home backup with the S6 inverter. The Power Hub will have three slots for inverter breakers to be connected in parallel. It will also have a generator connection and breaker slots for load shedding. The Power Hub will not launch until Q3 2023.

**Q7: What kind of data logger options will be available with this inverter?**

A7: There are three options available: (1) WiFi, (2) WiFi & 4G cellular, (3) WiFi & LAN

**Q8: Will I need to install an external rapid shutdown transmitter or does the inverter come with an internal transmitter? I heard that the inverter has an option for optimizers and module-level monitoring. Can you elaborate a bit more on that?**

A8: The S6 hybrid will have three options for internal RSD transmitters: (1) Entelgent (2) APS (3) Tigo. The Entelgent transmitter works with the Entelgent optimizers which also provide module-level monitoring on SolisCloud. Entelgent optimizers have two-way PLC communication, which allows the inverter to collect module-level data, which then gets displayed on SolisCloud. Please see the Compatible Module-Level Rapid Shutdown list on the website under the inverter listing.

# 8. Appendix

---

## 8.2 FAQs

### **Q9: Will the S6 hybrid work with a generator?**

A9: Yes, but you will need to install a Solis Power Hub as well. The inverter does not have a generator connection point, but it can work alongside a generator if the Power Hub is also installed since it does have a generator input. The Power Hub will automatically start up the generator if there is not enough PV/battery power to cover the load demand when the system is in backup or off-grid mode.

### **Q10: Where can I purchase the S6 hybrid?**

A10: Solis sells inverters through several different distributors. The PowerStore, Renvu, Krannich, and Inverter Supply will all be selling this inverter. You can also purchase the inverter on Amazon.com as well as directly from Solis if you are buying high-volume.

### **Q11: Can the inverter provide backup power with PV only and no battery?**

A11: As of right now, the answer is no. But we are working on adding this feature in Q2 2023. What it will look like is the inverter will be able to provide around 20A of backup as long as there is enough PV power. When the irradiance decreases, or the load demand exceeds 20A then the backup will shut off until the irradiance increases or the load demand decreases.

### **Q12: What kinds of energy storage modes will the S6 hybrid offer?**

A12: The S6 hybrid has multiple energy storage operating modes. For every mode, the first priority of the system is to support the home loads. **Self-Use Mode** makes the second priority charging the battery with excess PV power. If the battery is charged, the inverter will export the remaining power if the system is configured to allow it. **Feed-in-Priority Mode** makes the second priority exporting excess PV power. If the export power quota is being met, the remaining power will be used to charge the battery. Backup Mode establishes a minimum state-of-charge (SOC) which prevents the battery from being overdischarged. This mode can be enabled or disabled independently of the first two modes. **Off-Grid Mode** is used if there is no grid connected to the inverter. Essentially, this mode is like self-use mode but with export power turned off since there is no grid to accept any excess PV power. The inverter will derate if the battery is charged and load demand is low. The inverter will give an alarm message if the PV and battery power cannot support the load demand.

### **Q13: Is the S6 hybrid CEC listed and HECO certified for California and Hawaii?**

A13: The inverter models will be added to the CEC list in early Q2 2023. The HECO certification will be completed by the end of Q2 2023. Therefore, it can be installed in California (and every other state that requires CEC listing) starting in February 2023. The inverter can be installed in Hawaii starting in June 2023.



# 8. Appendix

## 8.3 Temperature Derating Curve

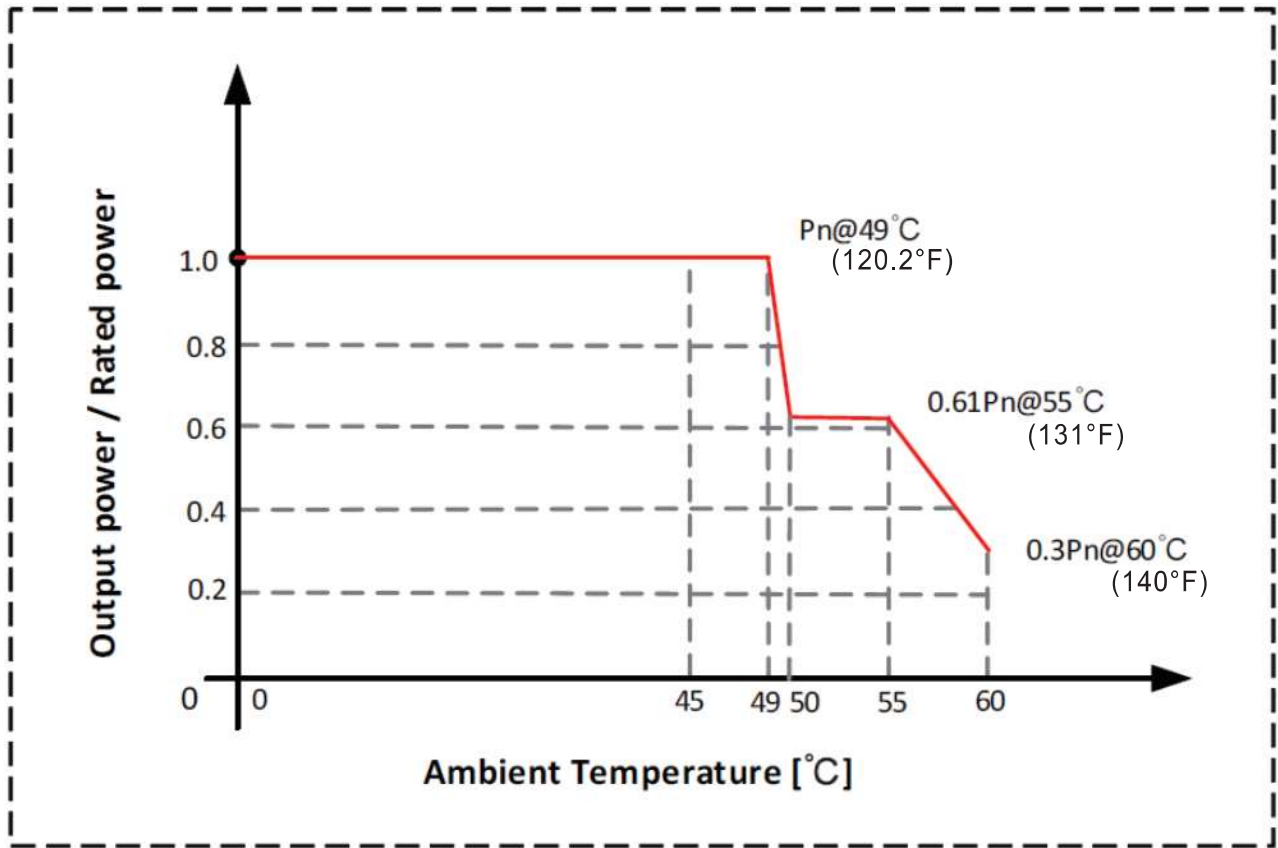

## 8.4 Inverter Internal Topology Overview

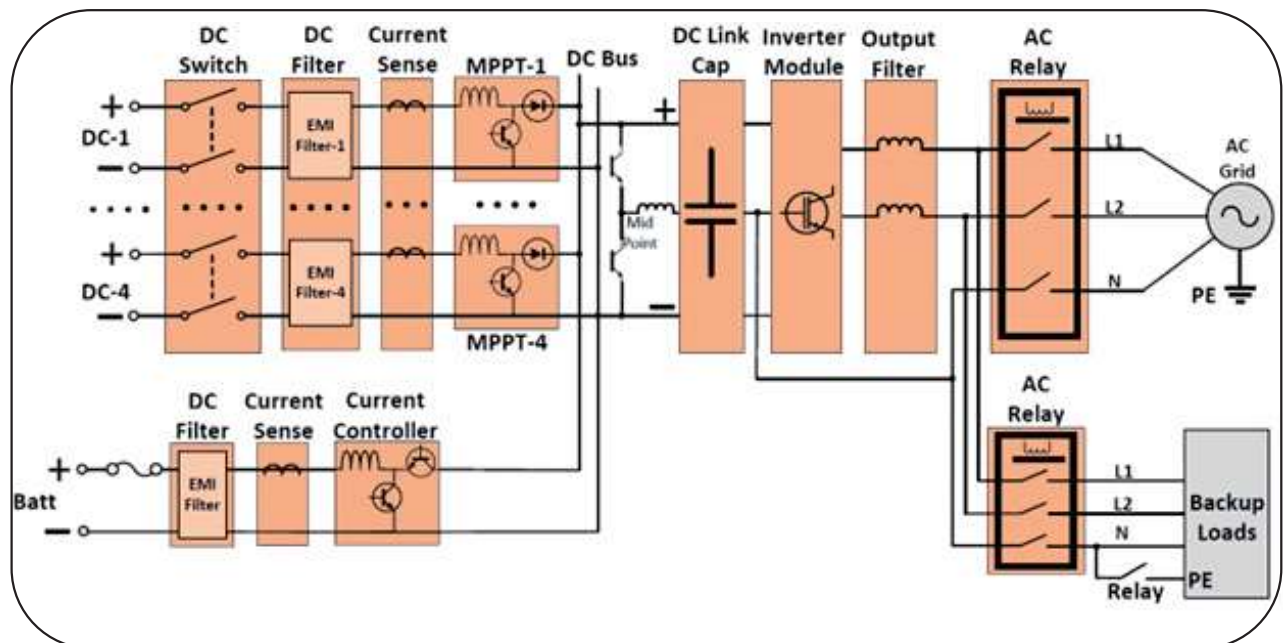



## 8.5 UL Certification



**Certificate:** 80127112  
**Project:** 80127113

**Master Contract:** 273488  
**Date Issued:** 2023-01-13

### APPLICABLE REQUIREMENTS

- |                       |   |   |
|-----------------------|---|---|
| CSA-C22.2 No.107.1-16 | - | Power Conversion Equipment  |
| *UL Std No. 1741      | - | Inverters, Converters, Controllers and Interconnection System Equipment for Use With Distributed Energy Resources (Third Edition, Dated September 28, 2021) |
| **UL 1699B            | - | Photovoltaic (PV) DC Arc-Fault Circuit Protection (First Edition, Revision Dated August 22, 2018)   |
| **UL1741 CRD          | - | Non-Isolated EPS Interactive PV Inverters Rated Less Than 30Kva (Dated April 26, 2010)  |

\*Note: Conformity to UL 1741(Third Edition, Dated September 28, 2021) includes compliance with applicable requirements of IEEE 1547-2003 (R2008), IEEE 1547a-2014, IEEE 1547.1-2005(R2011), IEEE 1547.1a-2015 for all models. Grid support function is verified according to UL 1741 Supplement SA8-SA18 with the SRDs of California Electric Rule 21, and also verified according to UL 1741 Supplement SB and IEEE 1547.1-2020 with the SRDs of IEEE 1547-2018 and IEEE 1547a-2020 for S6-EH1P(3.8-11.4)K-H-US series inverter. While the grid support function evaluated according to IEEE 1547.1-2020, the interoperability is verified with IEEE 2030.5-2018 communication protocol.

\*\*Note: The functional safety has been evaluated according to applicable requirement of UL 1998-Edition 3 as required by the product standard.

### Notes:

Products certified under Class C531109 have been certified under CSA's ISO/IEC 17065 accreditation with the Standards Council of Canada (SCC). [www.scc.ca](http://www.scc.ca)





## 8.5 UL Certification



### Supplement to Certificate of Compliance

**Certificate:** 80127112

**Master Contract:** 273488

*The products listed, including the latest revision described below, are eligible to be marked in accordance with the referenced Certificate.*

#### Product Certification History

Project	Date	Description
80127113	2023-01-13	Updated report 80127112 to add S6-EH1P(3.8-11.4)K-H-US series inverter, include models S6-EH1P3.8K-H-US, S6-EH1P5K-H-US, S6-EH1P6K-H-US, S6-EH1P7.6K-H-S-US, S6-EH1P7.6K-H-L-US, S6-EH1P8K-H-US, S6-EH1P10K-H-US, S6-EH1P11.4K-H-US and evaluate the Grid support function to comply with UL 1741 Supplement SA8-SA18 with the SRDs of California Electric Rule 21 and UL 1741 Supplement SB according to IEEE 1547.1-2020 with SRDS IEEE 1547-2018 and IEEE 1547a-2020.
80127112	2022-09-20	Bi-directional Transformerless Utility Interactive Power Conversion Equipment, S6-EH1P(3.8-11.4)K-H-MEX series, include Models S6-EH1P3.8K-H-MEX, S6-EH1P5K-H-MEX, S6-EH1P6K-H-MEX, S6-EH1P7.6K-H-S-MEX, S6-EH1P7.6K-H-L-MEX, S6-EH1P8K-H-MEX, S6-EH1P10K-H-MEX and S6-EH1P11.4K-H-MEX. (C/US)

Ginlong Technologies Co., Ltd.

No. 57 Jintong Road, Binhai Industrial Park, Xiangshan, Ningbo,  
Zhejiang, 315712, P.R.China.

Tel: +1(866)438-8408

Email:info@ginlong.com

Web:www.ginlong.com

If you encounter any problems with the inverter, please take note of the inverter serial number and then contact us using the phone number or email listed above.



SunSpec  
Certified



Compliant with CA Rule 21 & HECO Rule 14H  
Certified to UL 1741 SA and UL 1741 SB  
Certified to UL Std. No. 1741-Second Edition  
& CSA-C22.2 No.107.1-16