



PASSION FOR POWER.

# CATALOGUE

## Safe Product Solutions for Photovoltaics

### 2019/2020







# Hensel - A strong brand

With passion and energy, we ensure safe connections, so that electrical power in the low voltage is meaningfully distributed. Particular where high demands are placed on the electrical installation.

We win as a team, because every single one contributes substantially to success through his commitment, appearance and acting: for our customers, suppliers and partners - worldwide.

We use our long-term solution competence, to set new standards again and again.

And that as a family owned business - as HENSEL.

Philipp C. Hensel

Frank Dubberke

Michael Lehr





## Safe Product Solutions for Photovoltaics

Safe Product Solutions for Photovoltaics	6
Standard Requirements for the Installation of Photovoltaic Plants	7
System description	8
PV generator junction boxes	9 - 29
Solar Inverter Collectors	30 - 44
Accessories for Product Solutions for Photovoltaics, Typ Mi PV	45 - 56
Technical Data	57 - 66

Further technical information can be found on the Internet  
[www.hensel-electric.de](http://www.hensel-electric.de)

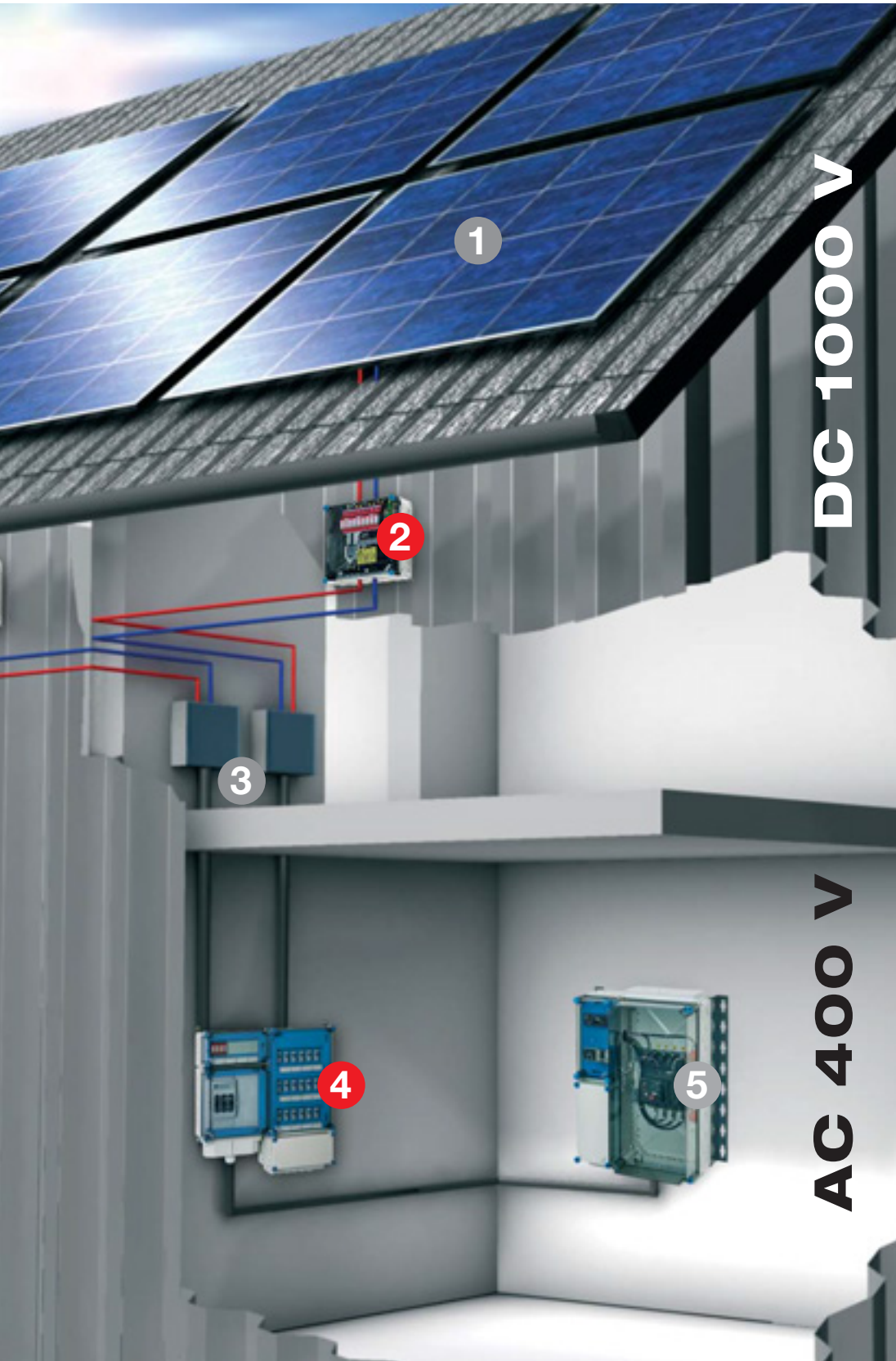

1



Solar panels

2



PV generator junction boxes

3



Inverters

4



Solar inverter collectors

5



Distributor with metering

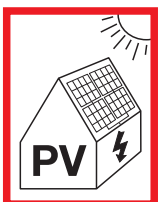
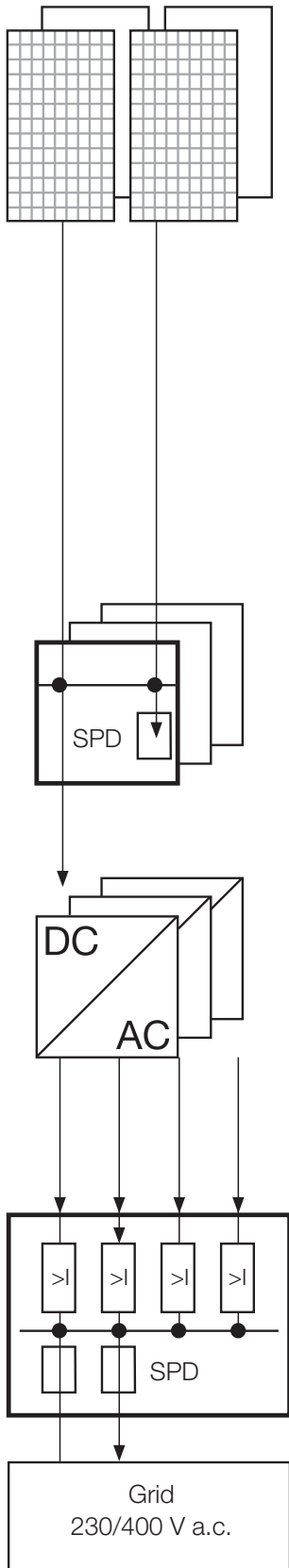

**In the setting up of photovoltaic power supply systems a multitude of standards and regulations are to be observed.**

The following standard requirements are listed in extract.

**IEC 60364-7-712 Electrical installations of buildings – requirements for special installations or locations – Solar photovoltaic (PV) power supply systems**

**PV module**

712.511.101

PV modules shall comply with the requirements of the relevant equipment standard, either IEC 61215 (all parts) or IEC 61646. for crystalline PV modules. PV modules of class II construction or with equivalent insulation are recommended if  $U_{OC\ STC}^{(1)}$  of the PV strings exceeds 120 V d.c..

712.512.1.1.102.2 PV module class

Where the protective measure used on the DC side is double or reinforced insulation according to 712.412, PV modules shall be selected according to class II or equivalent insulation according to IEC 61140.

**Generator junction boxes**

712.511.103

A combiner box shall comply with IEC 61439-2 or, for household and similar locations, may alternatively comply with IEC 60670 (relevant parts). Switchgear assemblies shall comply with IEC 61439 (relevant parts).

712.536.2.2.5.1

All junction boxes (PV generator and PV array boxes) shall carry a warning label indicating that active parts inside the boxes may still be live after isolation from the PV inverter.

712.512.1.1.102.3 Combiner box class

Where the protective measure used on the DC side is double or reinforced insulation according to 712.412, combiner boxes shall be selected according to **class II** or equivalent insulation according to IEC 61140.

**Solar inverters**

712.434.1

The PV supply cable on the AC side shall be protected by a short circuit or an overcurrent protective device installed at the connection to the AC mains.

712.536.2.2.1

In the selection and erection of devices for isolation and switching to be installed between the PV installation and the public supply, the public supply shall be considered the source and the **PV installation shall be considered the load.**

**IEC 61439-1**

**Low-voltage switchgear and controlgear assemblies - Part 1: General rules**

10.9.4 Testing of enclosures made of insulating material

For assemblies with enclosures made of insulating material, an additional dielectric test shall be carried out,...

**PV module solar inverter**

**Safety marking**

712.514.101

For reasons of safety of the various operators (maintenance personnel, inspectors, public distribution network operators, emergency aid services, etc.), it is essential to indicate the presence of a photovoltaic installation on a building.

A sign, such as shown in Figure 712.8, shall be fixed

- at the origin of the electrical installation, and
- at the metering position, if remote from the origin, and
- at the consumer unit or distribution board to which the supply from the PCE is connected.

# Dependent on the system

## Electrical parameters



Electrical parameters

Rated current: up to 630 A

Rated insulation voltage: 690 V a.c., **1000 V d.c.**, IEC 60664

The rated insulation voltage is possibly reduced by the installed equipment technology.

## System properties



Ambient conditions

Ambient temperature

- for distribution boards according to IEC 61439:

-5 °C up to 35 °C, max. + 40 °C

Relative humidity: 50% at 40 °C, 100% at 25 °C



Impact strength

degree of protection against mechanical load IK 08 (5 Joule) in accordance with IEC 62262



Application area

**The enclosures are suitable for protected outdoor installation**

However the climatic influences and effects on the equipment are to be considered, see pages "outdoor applications".



Protection against foreign solid objects and direct contact

Dust-proof  
Degree of protection IP **65**



Insulation

Insulated enclosures (Protection class II) 



Protection against ingress of water with harmful effects

Protected against water jets  
Degree of protection IP **65**

# Dependent on material

## Material: Polycarbonat



Burning behaviour

Glow wire test 960 °C in accordance with IEC 60695-2-11 flame-retardant, self-extinguishing



Chemical resistance

Resistance against acid 10% and lye 10%, petrol and mineral oil



UV resistance

UV resistance according to IEC 61439-1, Section 10.2.4: the material is examined for UV resistance

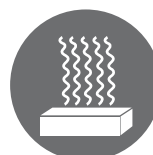

Toxic behaviour

Silicone- and halogen-free

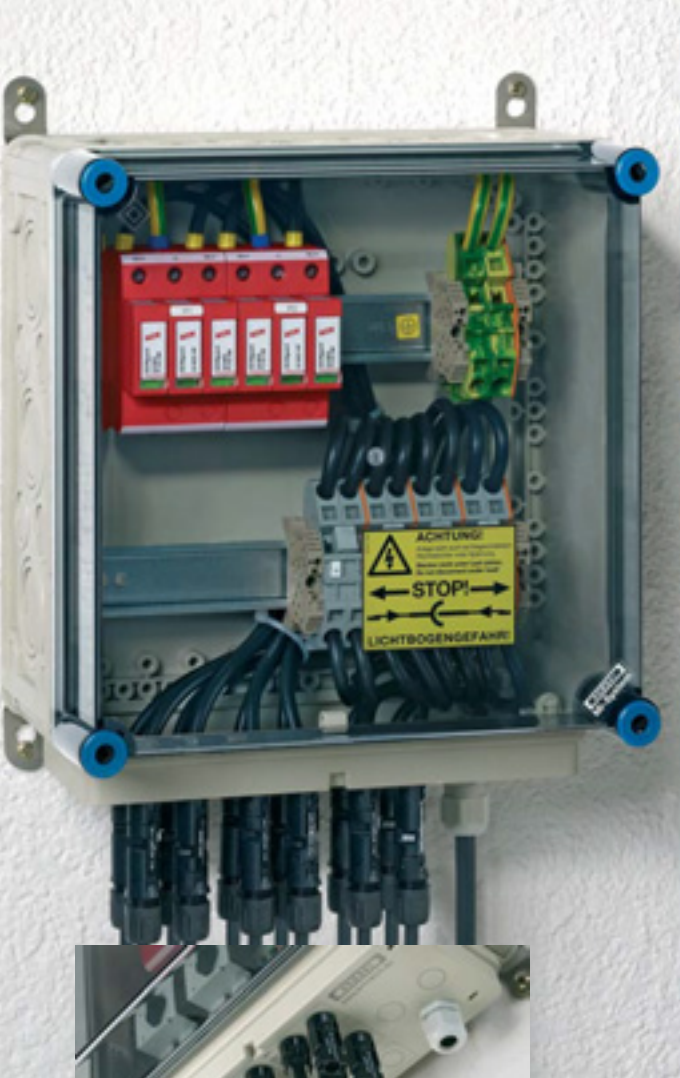

## ENYSUN

### PV generator junction boxes

- connection:  
ready for connection with plug connectors or included cable entries
- Electrical data:  
rated voltage: 1000 V d.c.  
rated current: up to 240 A  
protection measure: total insulation
- Environmental conditions:  
UV resistance  
Degree of protection: IP 65  
Optional: suitable products, to effectively reduce the accumulation of condensation water within the enclosure (e.g. combi climate gland, canopy, ventilation flange)

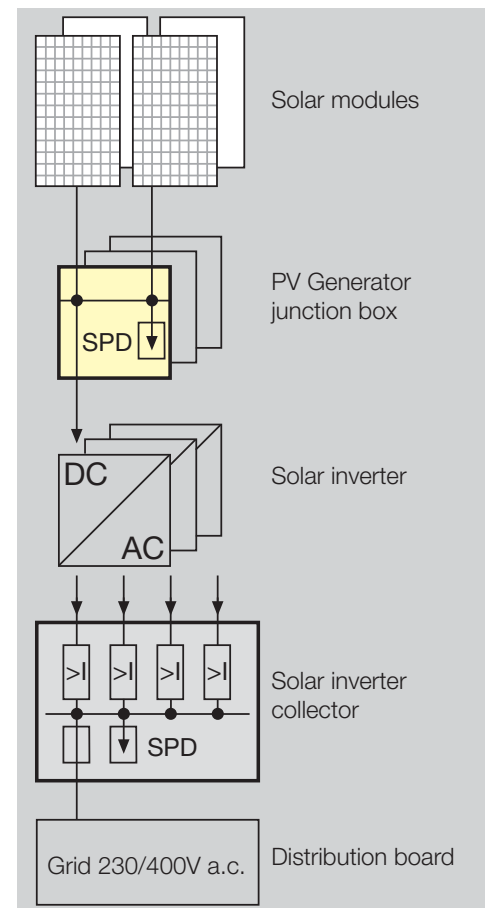



The materials used in Mi System enclosures are generally UV resistant meaning that the mechanical stability shall remain after UV exposure. Direct solar radiation as well as power dissipation within a box can overheat the interior of the box. Exterior temperatures that are too low e.g. under  $-5^{\circ}\text{C}$  can also influence the functioning of the equipment. Therefore climatic influence on the equipment needs to be taken into consideration. The top of the box should be protected with a cover to protect against impact created by weather conditions such as rain, ice and snow. Possible impact from chemical influences also needs to be taken into consideration when selecting an installation location, as well as IP degree of protection and climate impact. Additional measures might be necessary such as ventilation (note degree of protection) to assure that the maximum ambient temperature allowed is not exceeded for the installed equipment as well as to prevent condensation from forming. In outdoor installations Hensel combi climate glands (KBM) can be used for cable entry and pressure compensation as well (see accessories).

**How does condensed water occur in enclosures with a high degree of protection?**

Condensed water only forms in enclosures with a higher degree of protection than IP 54 due to temperature difference from inside to outside. Humidity can not evaporate because of the high degree of protection of the enclosure.

System switched on.

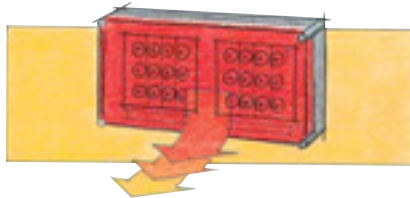

The internal temperature is higher than the external temperature due to the power dissipation of the built-in devices.

System switched on.

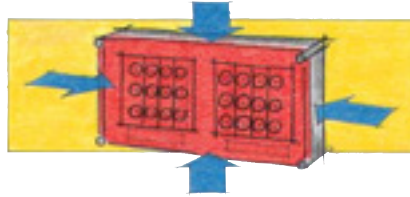

The warm air inside the enclosure attempts to accumulate moisture. This comes from outside through the seal as the enclosures are not gas-tight.

System switched off.



The internal temperature is reduced by cooling down the system e.g. by switching off the loads. The cooler air emits moisture which is collected as condensed water on the cooling inner surfaces.

**Formation of condensed water for indoor installations:**

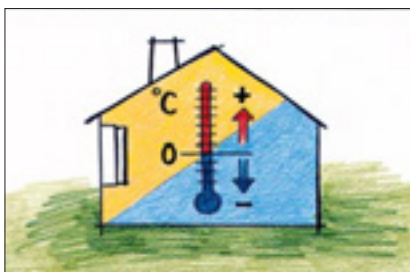

In areas where high levels of air humidity and large temperature fluctuations are expected e.g. in laundry rooms, kitchens, car washes etc.

**Formation of condensed water in protected outdoor installations (protected against weather influences) or unprotected outdoor installations:**

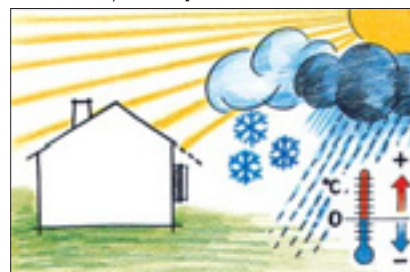

Here condensed water can be formed dependent on the weather, high air humidity, direct sunlight and temperature differences compared to the wall.

**Product solutions see accessories outdoor application**

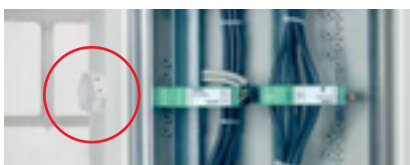

**Ambient conditions:**

Degree of protection: IP 65  
Stainless steel external brackets, optional: suitable products to effectively reduce the accumulation of condensation in enclosures (e.g. pressure compensation elements, canopy, ventilation flanges).



Through the exposed assembly of photovoltaic generators on rooftops or in the free surface the lightning and surge protection is an important part of investment protection.

Direct lightning strikes in the PV generator can for example destroy PV modules and inverters (primary damage).

Since photovoltaic (PV) systems necessarily have a connection to the electrical installation of the building, damages throughout the whole plant can result from lightning strikes in the PV generator (secondary effect).

**Protection measures**

Basically, it should be ensured that no direct lightning strike to the PV generator is possible. Well-known manufacturers offer suitable products for "external lightning protection systems."

If an external lightning protection system is installed, a lightning current arrester type 1 for the AC supply is required in the building main distribution board.

**Protection of solar inverters**

To protect the inverters against surge voltages, both the DC inputs and AC outputs must be protected. When the inverter is installed at a distance of more than 10 m cable length to the buildings main power distribution, then a surge protection device (SPD) type 2 for the AC line shall be used to prevent overvoltage damage, such as switching overvoltage from the electrical power supply.

For the string lines of the DC inputs special type 2 surge protection devices are to be provided, which are suitable for direct voltage. The decisive factor is the individual lightning and surge protection concept.

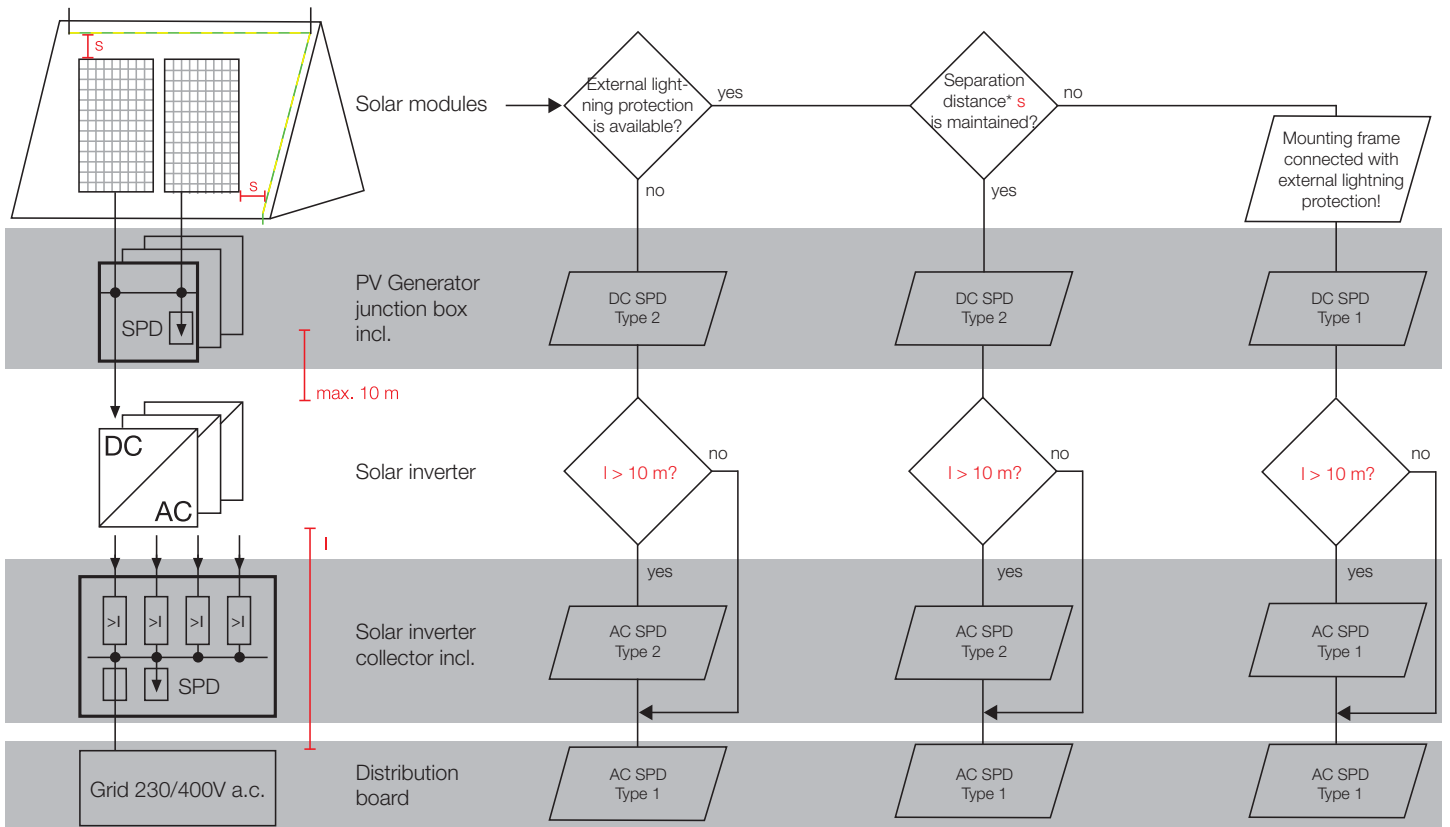

\* between lightning protection facility and PV plant

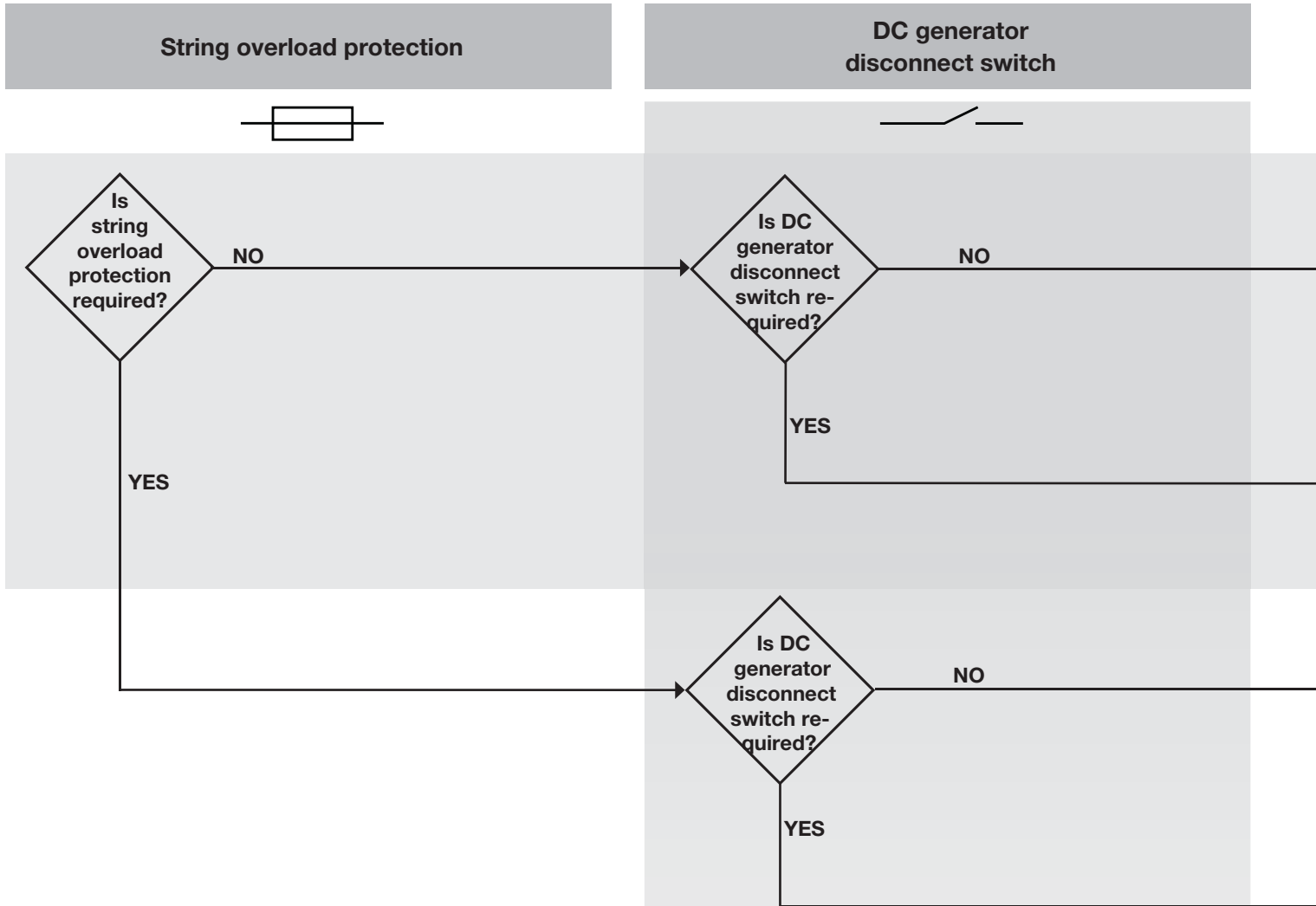

**712.430.3.103 Requirement for string overcurrent protection**

String overcurrent protection shall be used if:

$$((N_s - 1) \times I_{SC\_MAX}) > I_{MOD\_MAX\_OCPR}$$

where:

Ns is the total number of parallel connected strings protected by the nearest overcurrent protective device.

**712.430.3.102 Requirement for overcurrent protection**

Overcurrent protective devices required for the protection of PV modules and/or their wiring shall be selected to reliably and consistently operate within 2 h when an overcurrent of 135 % of the nominal device current rating of the PV modules is applied.

**712.514.106.2 PV array disconnecting device**

The PV array DC switch disconnecter shall be identified by a sign affixed in a prominent location adjacent to the switch disconnecter.

Where multiple disconnection devices are used that are not ganged (refer to 712.536.2.103) signage shall be provided warning of multiple DC sources and the need to turn off all switch disconnectors to safely isolate equipment.

**712.536.2.101 Disconnections means**

Disconnecting means with isolation function shall be provided for the inverter, on both the DC side and the AC side.

Disconnecting means with isolation function shall be provided in PV array to isolate circuits and equipment.

**DC surge arrester for PV plants (SPD)**

**Required protection device in PV generator junction boxes**

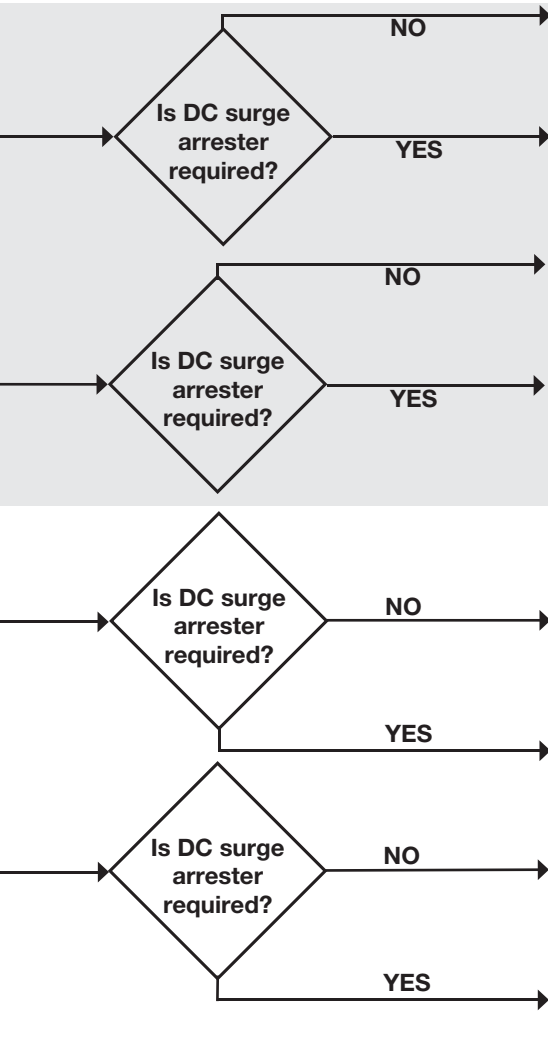

**Generator junction box with terminals**

**Generator junction box with DC surge arrester for PV plants**

**Generator junction box with DC generator disconnect switch**

**Generator junction box with DC generator disconnect switch and DC surge arrester for PV plants**

**Generator junction box with overload protection**

**Generator junction box with overload protection and DC surge arrester for PV plants**

**Generator junction box with overload protection and DC generator disconnect switch**

**Generator junction box with overload protection, DC generator disconnect switch and DC surge arrester for PV plants**



**712.534.4.4.101 Selection of SPDs on the DC side**

**712.534.4.4.101.1 General**

Due to the very specific electrical setup of PV installations on the DC side, only SPDs especially dedicated to PV installations shall be used to protect the DC side of such installations. The manufacturer of SPDs shall give the relevant information.

**712.534.4.4.101.4 Selection of SPD maximum continuous operating voltage  $U_{cpv}$**

The value of the maximum voltage acceptable by the surge protective device  $U_{cpv}$  shall be selected according to the maximum no-load voltage of the PV array  $U_{OC\ MAX}$ . The voltage  $U_{cpv}$  shall be greater than or equal to the maximum voltage  $U_{OC\ MAX}$  of the PV array.



**KV PV 1211**

**1 x PV string for 1 x inverter input**  
**1 x DC type 2 surge arrester**

- ready for connection
- 1 x DC type 2 surge arrester  
 max. outgoing surge current DC (8/20)  $I_{total}$ : 40 kA  
 protection level DC: < 4 kV
- plug-in connectors compatible to MC4  
 connection cable length: 2 x 500 mm
- rated connecting capacity PE: 1.5-16 mm<sup>2</sup>, Cu
- with stainless steel mounting plate for wall and post installations

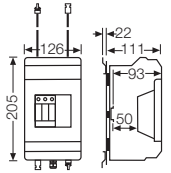

rated voltage	$U_{OC,STC} = 1000 \text{ V d.c.}$
Rated current of the power switchgear and controlgear assembly	$I_{NA} = 30 \text{ A}$
rated current of a circuit	$I_{nc} = 30 \text{ A}$
RDF (Rated Diversity Factor)	1



**KV PV 2211**

**1 x PV string for 1 x inverter input**  
**1 x DC generator disconnect switch**

- ready for connection
- 1 x DC generator disconnect switch  
 utilization category for switch disconnectors: DC-21 A =  
 Switching ohmic loads inclusively moderate overload
- plug-in connectors compatible to MC4  
 connection cable length: 2 x 500 mm
- with stainless steel mounting plate for wall and post installations

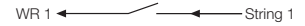
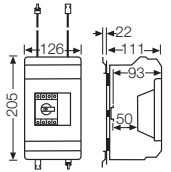

rated voltage	$U_{OC,STC} = 1000 \text{ V d.c.}$
Rated current of the power switchgear and controlgear assembly	$I_{NA} = 30 \text{ A}$
rated current of a circuit	$I_{nc} = 30 \text{ A}$
RDF (Rated Diversity Factor)	1

**Installation of KV PV ... generator junction box Possible in standard wall and post mounting.**



Connection to solar inverter only with DC and AC surge arrester

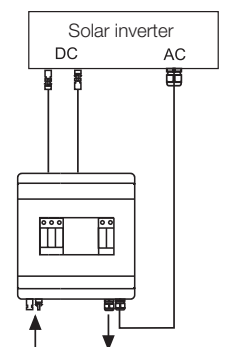



**KV PV 2411**

**1 x PV string for 1 x inverter input**  
**1 x DC type 2 surge arrester and 1 x DC generator disconnect switch**



- ready for connection
- 1 x DC type 2 surge arrester  
 max. outgoing surge current DC (8/20)  $I_{total}$ : 40 kA  
 protection level DC: < 4 kV
- 1 x DC generator disconnect switch  
 utilization category for switch disconnectors: DC-21 A =  
 Switching ohmic loads inclusively moderate overload
- plug-in connectors compatible to MC4  
 connection cable length: 2 x 500 mm
- rated connecting capacity PE: 1.5-16 mm<sup>2</sup>, Cu
- with stainless steel mounting plate for wall and post installations

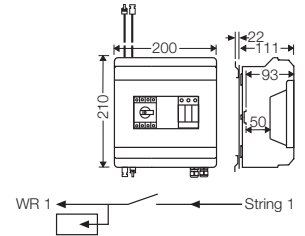

rated voltage	$U_{OC,STC} = 1000 \text{ V d.c.}$
Rated current of the power switchgear and controlgear assembly	$I_{NA} = 30 \text{ A}$
rated current of a circuit	$I_{nc} = 30 \text{ A}$
RDF (Rated Diversity Factor)	1

To protect from unauthorized access



Locking device  
KV ES 3



Sealing device  
KV PL 3



**Mi PV 1111**

**1 x PV string for 1 x inverter input**  
**1 x DC type 2 surge arrester**

- ready for connection
- 1 x DC type 2 surge arrester  
max. outgoing surge current DC (8/20)  $I_{total}$ : 40 kA  
protection level DC: < 4 kV
- plug-in connectors compatible with MC4
- rated connecting capacity PE: 1.5-16 mm<sup>2</sup>, Cu
- lid fasteners for tool operation
- with stainless steel external brackets

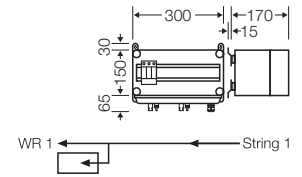

rated voltage	$U_{OC,STC} = 1000 \text{ V d.c.}$
Rated current of the power switchgear and controlgear assembly	$I_{NA} = 1 \times 30 \text{ A}$
rated current of a circuit	$I_{nc} = 30 \text{ A}$
RDF (Rated Diversity Factor)	1



**Mi PV 1122**

**2 x PV string for 2 x inverter input**  
**2 x DC type 2 surge arrester**

- ready for connection
- 1 x DC type 2 surge arrester  
max. outgoing surge current DC (8/20)  $I_{total}$ : 40 kA  
protection level DC: < 4 kV
- plug-in connectors compatible with MC4
- rated connecting capacity PE: 1.5-16 mm<sup>2</sup>, Cu
- lid fasteners for tool operation
- with stainless steel external brackets

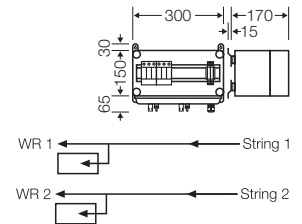

rated voltage	$U_{OC,STC} = 1000 \text{ V d.c.}$
Rated current of the power switchgear and controlgear assembly	$I_{NA} = 2 \times 30 \text{ A}$
rated current of a circuit	$I_{nc} = 30 \text{ A}$
RDF (Rated Diversity Factor)	1



**Mi PV 1133**

**3 x PV string for 3 x inverter input**  
**3 x DC type 2 surge arrester**

- ready for connection
- 1 x DC type 2 surge arrester  
max. outgoing surge current DC (8/20)  $I_{total}$ : 40 kA  
protection level DC: < 4 kV
- plug-in connectors compatible with MC4
- rated connecting capacity PE: 1.5-16 mm<sup>2</sup>, Cu
- lid fasteners for tool operation
- with stainless steel external brackets

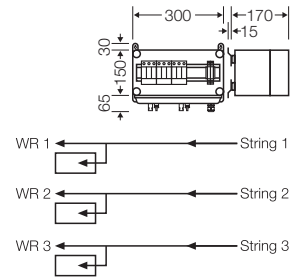

rated voltage	$U_{OC,STC} = 1000 \text{ V d.c.}$
Rated current of the power switchgear and controlgear assembly	$I_{NA} = 3 \times 30 \text{ A}$
rated current of a circuit	$I_{nc} = 30 \text{ A}$
RDF (Rated Diversity Factor)	1

Accessories to reduce condensed water



Combi climate glands KB ..



Canopy



Ventilation flange  
Mi BF 44



**Mi PV 1121**

**2 x PV string for 1 x inverter input**  
**1 x DC type 2 surge arrester**

- ready for connection
- 1 x DC type 2 surge arrester  
max. outgoing surge current DC (8/20)  $I_{total}$ : 40 kA  
protection level DC: < 4 kV
- plug-in connectors compatible with MC4
- rated connecting capacity PE: 1.5-16 mm<sup>2</sup>, Cu
- lid fasteners for tool operation
- with stainless steel external brackets

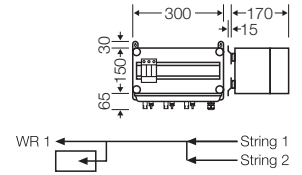

rated voltage	$U_{OC,STC} = 1000 \text{ V d.c.}$
Rated current of the power switchgear and controlgear assembly	$I_{NA} = 1 \times 30 \text{ A}$
rated current of a circuit	$I_{nc} = 15 \text{ A}$
RDF (Rated Diversity Factor)	1



**Mi PV 1242**

**4 x PV string for 2 x inverter input**  
**2 x DC type 2 surge arrester**

- ready for connection
- 1 x DC type 2 surge arrester  
max. outgoing surge current DC (8/20)  $I_{total}$ : 40 kA  
protection level DC: < 4 kV
- plug-in connectors compatible with MC4
- rated connecting capacity PE: 1.5-16 mm<sup>2</sup>, Cu
- lid fasteners for tool operation
- with stainless steel external brackets

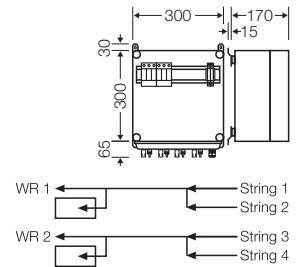

rated voltage	$U_{OC,STC} = 1000 \text{ V d.c.}$
Rated current of the power switchgear and controlgear assembly	$I_{NA} = 2 \times 30 \text{ A}$
rated current of a circuit	$I_{nc} = 15 \text{ A}$
RDF (Rated Diversity Factor)	1



**Mi PV 1263**

**6 x PV string for 3 x inverter input**  
**3 x DC type 2 surge arrester**

- ready for connection
- 1 x DC type 2 surge arrester  
max. outgoing surge current DC (8/20)  $I_{total}$ : 40 kA  
protection level DC: < 4 kV
- plug-in connectors compatible with MC4
- rated connecting capacity PE: 1.5-16 mm<sup>2</sup>, Cu
- lid fasteners for tool operation
- with stainless steel external brackets

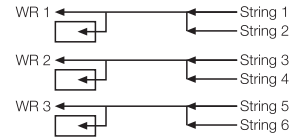
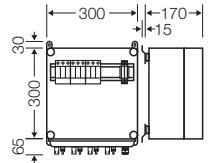

rated voltage	$U_{OC\ STC} = 1000\ V\ d.c.$
Rated current of the power switchgear and controlgear assembly	$I_{NA} = 3 \times 30\ A$
rated current of a circuit	$I_{nc} = 15\ A$
RDF (Rated Diversity Factor)	1

Accessories to reduce condensed water



Combi climate glands KB ..



Canopy



Ventilation flange  
Mi BF 44



**Mi PV 2111**

**1 x PV string for 1 x inverter input**  
**1 x DC type 2 surge arrester and**  
**1 x DC generator disconnect switch**



- ready for connection
- 1 x DC type 2 surge arrester  
max. outgoing surge current DC (8/20)  $I_{total}$ : 40 kA  
protection level DC: < 4 kV
- 1 x DC generator disconnect switch  
utilization category for switch disconnectors: DC-21 A =  
Switching ohmic loads inclusively moderate overload
- plug-in connectors compatible with MC4
- rated connecting capacity PE: 1.5-16 mm<sup>2</sup>, Cu
- lid fasteners for tool operation
- with stainless steel external brackets

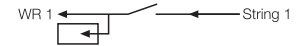
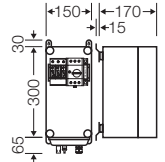

rated voltage	$U_{OC,STC} = 1000 \text{ V d.c.}$
Rated current of the power switchgear and controlgear assembly	$I_{NA} = 1 \times 30 \text{ A}$
rated current of a circuit	$I_{nc} = 30 \text{ A}$
RDF (Rated Diversity Factor)	1



**Mi PV 2222**

**2 x PV string for 2 x inverter input**  
**2 x DC type 2 surge arrester and**  
**2 x DC generator disconnect switch**



- ready for connection
- 1 x DC type 2 surge arrester  
max. outgoing surge current DC (8/20)  $I_{total}$ : 40 kA  
protection level DC: < 4 kV
- 1 x DC generator disconnect switch  
utilization category for switch disconnectors: DC-21 A =  
Switching ohmic loads inclusively moderate overload
- plug-in connectors compatible with MC4
- rated connecting capacity PE: 1.5-16 mm<sup>2</sup>, Cu
- lid fasteners for tool operation
- with stainless steel external brackets

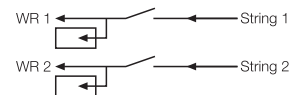
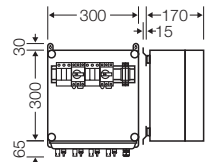

rated voltage	$U_{OC,STC} = 1000 \text{ V d.c.}$
Rated current of the power switchgear and controlgear assembly	$I_{NA} = 2 \times 30 \text{ A}$
rated current of a circuit	$I_{nc} = 30 \text{ A}$
RDF (Rated Diversity Factor)	1



**Mi PV 2233**

**3 x PV string for 3 x inverter input**  
**3 x DC type 2 surge arrester and**  
**3 x DC generator disconnect switch**



- ready for connection
- 1 x DC type 2 surge arrester  
 max. outgoing surge current DC (8/20)  $I_{total}$ : 40 kA  
 protection level DC: < 4 kV
- 1 x DC generator disconnect switch  
 utilization category for switch disconnectors: DC-21 A =  
 Switching ohmic loads inclusively moderate overload
- plug-in connectors compatible with MC4
- rated connecting capacity PE: 1.5-16 mm<sup>2</sup>, Cu
- lid fasteners for tool operation
- with stainless steel external brackets

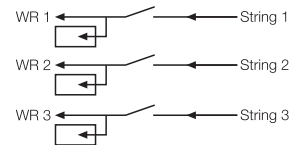
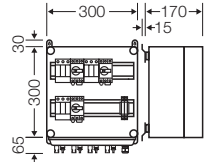

rated voltage	$U_{OC,STC} = 1000 \text{ V d.c.}$
Rated current of the power switchgear and controlgear assembly	$I_{NA} = 3 \times 30 \text{ A}$
rated current of a circuit	$I_{nc} = 30 \text{ A}$
RDF (Rated Diversity Factor)	1

To protect from unauthorized access



Sealing cap  
Mi PL 2



Lid lock with locking device  
Mi ZS 1x



Lid fastener for tool operation  
Mi DR 04



**Mi PV 2121**

**2 x PV string for 1 x inverter input**  
**1 x DC type 2 surge arrester and**  
**1 x DC generator disconnect switch**



- ready for connection
- 1 x DC type 2 surge arrester  
max. outgoing surge current DC (8/20)  $I_{total}$ : 40 kA  
protection level DC: < 4 kV
- 1 x DC generator disconnect switch  
utilization category for switch disconnectors: DC-21 A =  
Switching ohmic loads inclusively moderate overload
- plug-in connectors compatible with MC4
- rated connecting capacity PE: 1.5-16 mm<sup>2</sup>, Cu
- lid fasteners for tool operation
- with stainless steel external brackets

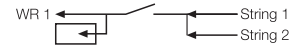
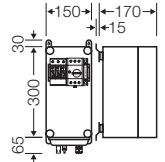

rated voltage	$U_{OC,STC} = 1000 \text{ V d.c.}$
Rated current of the power switchgear and controlgear assembly	$I_{NA} = 1 \times 30 \text{ A}$
rated current of a circuit	$I_{nc} = 15 \text{ A}$
RDF (Rated Diversity Factor)	1



**Mi PV 2242**

**4 x PV string for 2 x inverter input**  
**2 x DC type 2 surge arrester and**  
**2 x DC generator disconnect switch**



- ready for connection
- 1 x DC type 2 surge arrester  
max. outgoing surge current DC (8/20)  $I_{total}$ : 40 kA  
protection level DC: < 4 kV
- 1 x DC generator disconnect switch  
utilization category for switch disconnectors: DC-21 A =  
Switching ohmic loads inclusively moderate overload
- plug-in connectors compatible with MC4
- rated connecting capacity PE: 1.5-16 mm<sup>2</sup>, Cu
- lid fasteners for tool operation
- with stainless steel external brackets

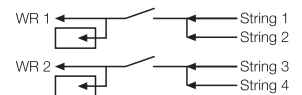
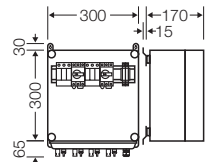

rated voltage	$U_{OC,STC} = 1000 \text{ V d.c.}$
Rated current of the power switchgear and controlgear assembly	$I_{NA} = 2 \times 30 \text{ A}$
rated current of a circuit	$I_{nc} = 15 \text{ A}$
RDF (Rated Diversity Factor)	1



**Mi PV 2263**

**6 x PV string for 3 x inverter input**  
**3 x DC type 2 surge arrester and**  
**3 x DC generator disconnect switch**



- ready for connection
- 1 x DC type 2 surge arrester  
max. outgoing surge current DC (8/20)  $I_{total}$ : 40 kA  
protection level DC: < 4 kV
- 1 x DC generator disconnect switch  
utilization category for switch disconnectors: DC-21 A =  
Switching ohmic loads inclusively moderate overload
- plug-in connectors compatible with MC4
- rated connecting capacity PE: 1.5-16 mm<sup>2</sup>, Cu
- lid fasteners for tool operation
- with stainless steel external brackets

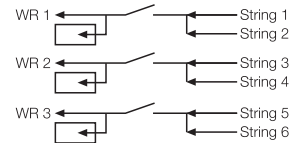
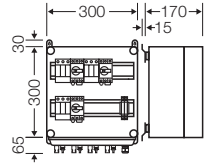

rated voltage	$U_{OC,STC} = 1000 \text{ V d.c.}$
Rated current of the power switchgear and controlgear assembly	$I_{NA} = 3 \times 30 \text{ A}$
rated current of a circuit	$I_{nc} = 15 \text{ A}$
RDF (Rated Diversity Factor)	1

To protect from unauthorized access



Sealing cap  
Mi PL 2



Lid lock with locking device  
Mi ZS 1x



Lid fastener for tool operation  
Mi DR 04



**Mi PV 1171**

**2 x PV string for 1 x inverter input**  
**1 x DC Surge arrester type 1 + 2**

- ready for connection
- DC type 1 + 2 surge arrester  
 lightning surge current DC (10/350) [DC+/DC- -> PE]  $I_{imp}$ : 12,5 kA  
 protection level [DC+/DC- -> PE]: < 2,5 kV
- plug-in connectors compatible with MC4
- rated connecting capacity PE: 1,5-25 mm<sup>2</sup>, Cu
- lid fasteners for tool operation
- with stainless steel external brackets

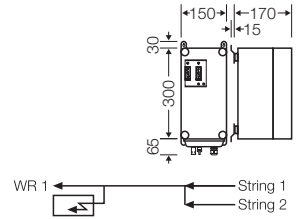

rated voltage	$U_{OC,STC} = 1000 \text{ V d.c.}$
Rated current of the power switchgear and controlgear assembly	$I_{nA} = 1 \times 30 \text{ A}$
rated current of a circuit	$I_{nc} = 15 \text{ A}$
RDF (Rated Diversity Factor)	1



**Mi PV 2171**

**2 x PV string for 1 x inverter input**  
**1 x DC Surge arrester type 1 + 2 and**  
**1 x DC Generator disconnect switch**



- ready for connection
- DC type 1 + 2 surge arrester  
 lightning surge current DC (10/350) [DC+/DC- -> PE]  $I_{imp}$ : 12,5 kA  
 protection level [DC+/DC- -> PE]: < 2,5 kV
- 1 x DC generator disconnect switch  
 utilization category for switch disconnectors: DC-21 A =  
 Switching ohmic loads inclusively moderate overload
- plug-in connectors compatible with MC4
- rated connecting capacity PE: 1,5-25 mm<sup>2</sup>, Cu
- lid fasteners for tool operation
- with stainless steel external brackets

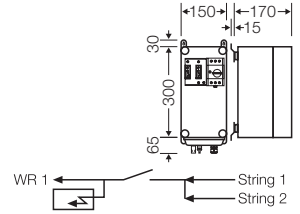

rated voltage	$U_{OC\ STC} = 1000\text{ V d.c.}$
Rated current of the power switchgear and controlgear assembly	$I_{nA} = 1 \times 30\text{ A}$
rated current of a circuit	$I_{nc} = 15\text{ A}$
RDF (Rated Diversity Factor)	1



**Mi PV 3311**

**6 x PV string for 1 x inverter input**  
**2 x DC generator disconnect switch**

- ready for connection
- 6 holder for fuses each + and - connection: 1.5-16 mm<sup>2</sup> Cu
- 2 x DC Generator disconnect switch  
 Utilization category for switch disconnectors: DC-21A = Switching ohmic loads inclusively moderate overload
- connection: 6-35 mm<sup>2</sup>, Cu
- lid fasteners for tool operation
- included cable entry: 12 x AKM 16, 2 x AKM 25
- with stainless steel external brackets

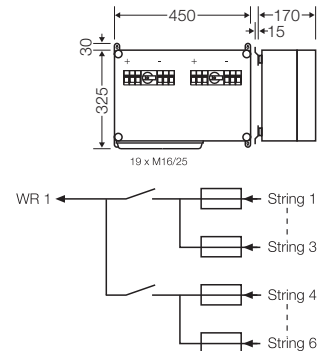

rated voltage	$U_{OC,STC} = 1000 \text{ V d.c.}$
Rated current of the power switchgear and controlgear assembly	$I_{NA} = 60 \text{ A}$
rated current of a circuit	$I_{nc} = 10 \text{ A}$
RDF (Rated Diversity Factor)	1



**Mi PV 3321**

**6 x PV string for 1 x inverter input**  
**1 x DC type 2 surge arrester and 2 x DC generator disconnect switch**

- ready for connection
- 6 holder for fuses each + and - connection: 1.5-16 mm<sup>2</sup> Cu
- 2 x DC Generator disconnect switch  
 Utilization category for switch disconnectors: DC-21A = Switching ohmic loads inclusively moderate overload
- connection: 6-35 mm<sup>2</sup>, Cu
- 1 x DC type 2 surge arrester  
 max. outgoing surge current DC (8/20)  $I_{total}$ : 40 kA  
 protection level DC: < 4 kV
- rated connecting capacity PE: 1,5-35 mm<sup>2</sup>, Cu
- lid fasteners for tool operation
- included cable entry: 12 x AKM 16, 3 x AKM 25
- with stainless steel external brackets

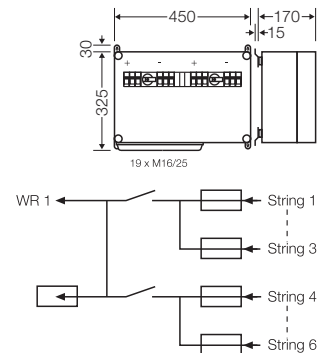

rated voltage	$U_{OC,STC} = 1000 \text{ V d.c.}$
Rated current of the power switchgear and controlgear assembly	$I_{NA} = 60 \text{ A}$
rated current of a circuit	$I_{nc} = 10 \text{ A}$
RDF (Rated Diversity Factor)	1



**Mi PV 3611**  
**12 x PV string for 1 x inverter input**  
**1 x DC generator disconnect switch**

- ready for connection
- for each 12 fuse holders + and - connection: 1.5-16 mm<sup>2</sup> Cu
- 1 x DC Generator disconnect switch connection: M 10 (max. 1 x 120 mm<sup>2</sup> per pole)
- lid fasteners for tool operation
- included cable entry: 12 x AKM 16, 12 x AKM 20, 2 x AKM 25
- with stainless steel external brackets

rated voltage	$U_{OC\ STC} = 1000\ V\ d.c.$
Rated current of the power switchgear and controlgear assembly	$I_{nA} = 120\ A$
rated current of a circuit	$I_{nc} = 10\ A$
RDF (Rated Diversity Factor)	1

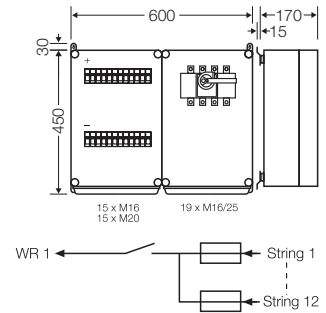

**Mi PV 3621**  
**12 x PV string for 1 x inverter input**  
**1 x DC type 2 surge arrester and 1 x DC generator disconnect switch**

- ready for connection
- for each 12 fuse holders + and - connection: 1.5-16 mm<sup>2</sup> Cu
- 1 x DC Generator disconnect switch connection: M 10 (max. 1 x 120 mm<sup>2</sup> per pole)
- 1 x DC type 2 surge arrester max. outgoing surge current DC (8/20)  $I_{total}$ : 40 kA protection level DC: < 4 kV
- rated connecting capacity PE: 1,5-35 mm<sup>2</sup>, Cu
- lid fasteners for tool operation
- included cable entry: 12 x AKM 16, 12 x AKM 20, 3 x AKM 25
- with stainless steel external brackets

rated voltage	$U_{OC\ STC} = 1000\ V\ d.c.$
Rated current of the power switchgear and controlgear assembly	$I_{nA} = 120\ A$
rated current of a circuit	$I_{nc} = 10\ A$
RDF (Rated Diversity Factor)	1

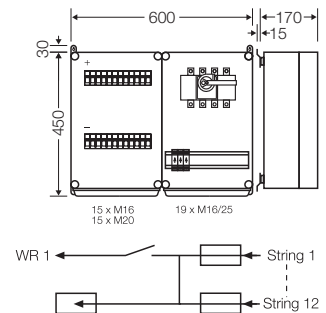

Accessories to reduce condensed water



Combi climate glands KB ..



Canopy



Ventilation flange  
 Mi BF 44



**Mi PV 3931**

**24 x PV string for 1 x inverter input**  
**1 x DC generator disconnect switch**

- ready for connection
- for each 24 fuse holders + and - connection: 1.5-16 mm<sup>2</sup> Cu
- 1 x DC Generator disconnect switch connection: M 10 (max. 1 x 120 mm<sup>2</sup> per pole)
- lid fasteners for tool operation
- included cable entry: 24 x AKM 16, 24 x AKM 20, 2 x AKM 40
- with stainless steel external brackets

rated voltage	$U_{OC,STC} = 1000 \text{ V d.c.}$
Rated current of the power switchgear and controlgear assembly	$I_{nA} = 240 \text{ A}$
rated current of a circuit	$I_{nc} = 10 \text{ A}$
RDF (Rated Diversity Factor)	1

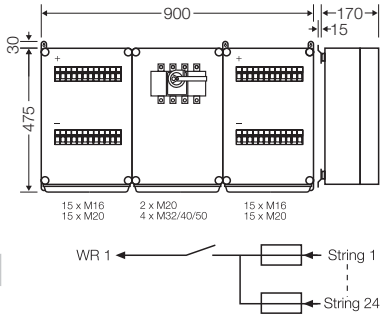

**Mi PV 3941**

**24 x PV string for 1 x inverter input**  
**1 x DC type 2 surge arrester and 1 x DC generator disconnect switch**

- ready for connection
- for each 24 fuse holders + and - connection: 1.5-16 mm<sup>2</sup> Cu
- 1 x DC Generator disconnect switch connection: M 10 (max. 1 x 120 mm<sup>2</sup> per pole)
- 1 x DC type 2 surge arrester max. outgoing surge current DC (8/20)  $I_{total}$ : 40 kA protection level DC: < 4 kV
- rated connecting capacity PE: 1,5-35 mm<sup>2</sup>, Cu
- lid fasteners for tool operation
- included cable entry: 24 x AKM 16, 25 x AKM 20, 2 x AKM 40
- with stainless steel external brackets

rated voltage	$U_{OC,STC} = 1000 \text{ V d.c.}$
Rated current of the power switchgear and controlgear assembly	$I_{nA} = 240 \text{ A}$
rated current of a circuit	$I_{nc} = 10 \text{ A}$
RDF (Rated Diversity Factor)	1

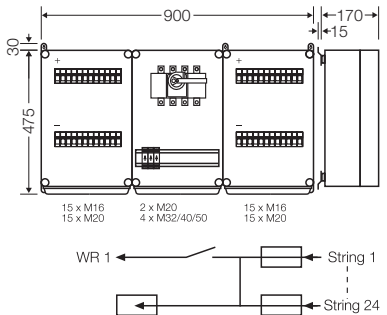

Accessories to reduce condensed water



Combi climate glands KB ..



Canopy



Ventilation flange  
Mi BF 44

Photovoltaik

Generator junction boxes **up to 1000 A**  
 made of insulation material in protection class: II,  
 degree of protection: up to IP 65

**Customised solutions?**  
**Contact us!**

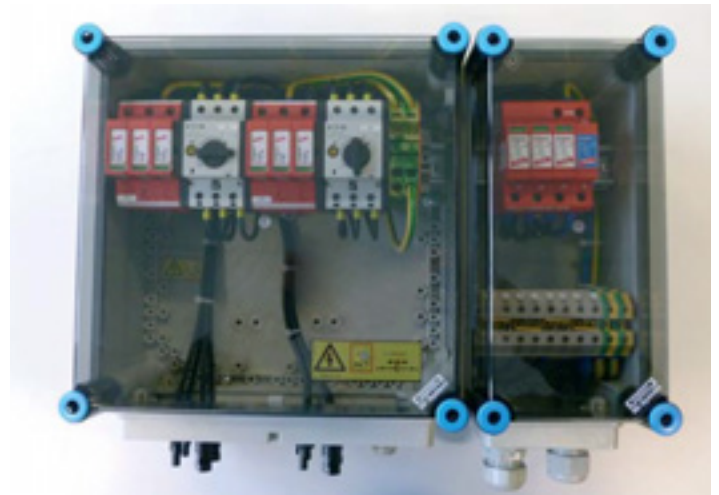
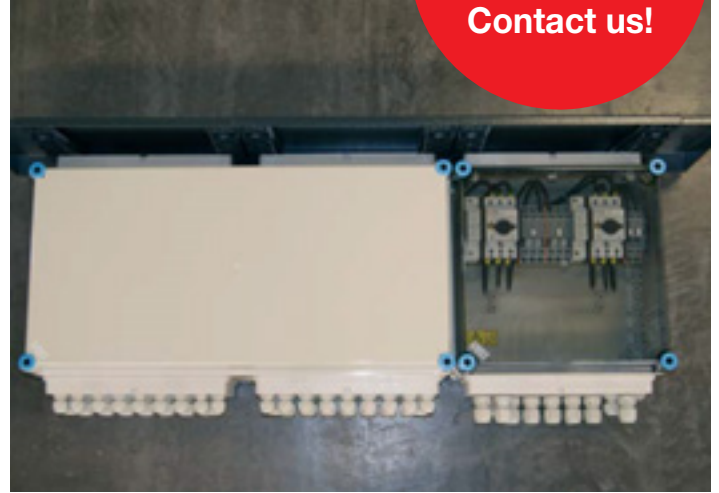



## ENYSUN

### Solar inverter collector

- Complete set:  
pre-fabricated and tested solar inverter collector solutions
- Electrical data:  
Rated voltage: 230/400 V a.c.  
Rated capacity: up to 220 kVA  
Degree of protection: up to IP 65  
optional with surge arrester
- Derating:  
Taking account of the thermal effects in generating plants, spacers ensure ventilation and degree of protection IP 2X

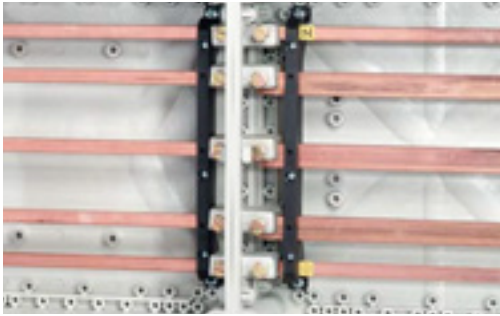

### EMC compliant busbar

The busbar system comes standard with N/PEN conductors in the phase conductor area. The N busbars have the same current carrying capacity as the phase conductor.

These busbars are appropriate for:

- Harmonics created by the solar inverter.
- Unbalanced loads (Unbalanced load limit 4.6 kVA allowed by power supply companies) created by power supply companies.



### Connection of large cable cross-sections

By using a cable insert in combination with strain relief for inverter-collectors from 140 kVA an easy connection of large cable cross-sections is possible.

When using a cable insertion the cables are inserted from the front. As a result, cables must not be inserted via cable glands.

To obtain degree of protection the strain relief keeps the cables connected centred within the stepped grommet. In addition, the cables are strain- and pressure relieved.

**Solar inverter collector supplied as set**

PV inverter collectors are supplied as a complete set. All necessary parts are put together in one set.

The individual housings are ready for connection and tested. They can be mounted to distribution boards, in order to realize a customized assembly according to the individual locations.



PV inverter collectors can be extended with lightning or surge protection and residual current protection (RCD) basing on pre-engineered enclosure solutions, thus offering optimal solutions for all requirements.

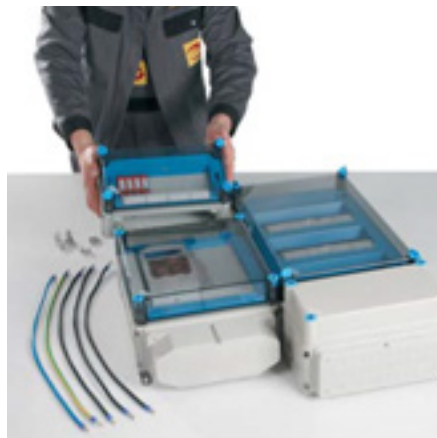

Installation variations of a complete set

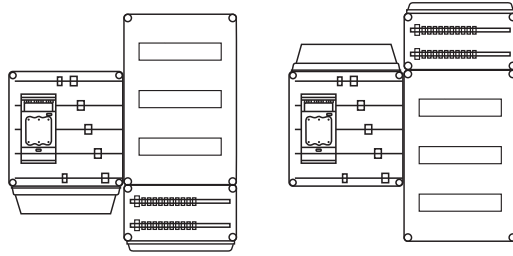

Wiring from the same direction

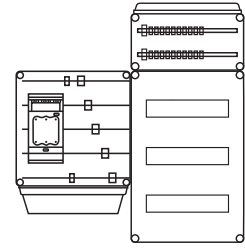

Wiring from different directions

Example: Extension of the complete set Mi PV 6123

- with surge protection device box (SPD)

Parts list for example:

1 x Mi PV 6123	Solar inverter collectors 140 kVA with circuit-breaker box
1 x Mi PV 5611	Surge protection device box (SPD)

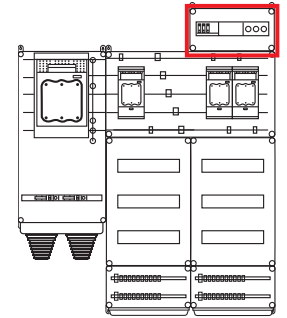

- with enclosures for residual current protection (RCD)

Parts list for example:

1 x Mi PV 6123	Solar inverter collectors 140 kVA with circuit-breaker box
2 x Mi PV 5711	circuit-breaker box

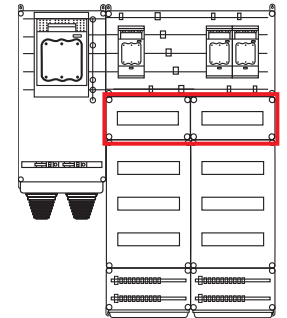

- with surge protection device box (SPD) and enclosures for residual current protection (RCD)

Parts list for example:

1 x Mi PV 6123	Solar inverter collectors 140 kVA with circuit-breaker box
1 x Mi PV 5611	Surge protection device box (SPD)
2 x Mi PV 5711	circuit-breaker box

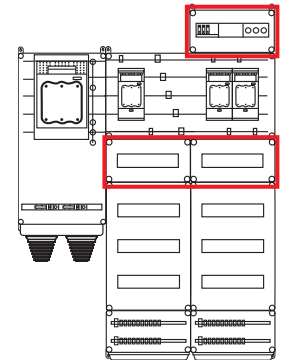

Extension of terminal compartment for the 70 mm<sup>2</sup> connection

Mi PV 6111 (70 kVA) complete set

Extension:  
Mi 010X empty box, Mi WD 2 wall gasket and terminal for direct busbar connection KS 70 F

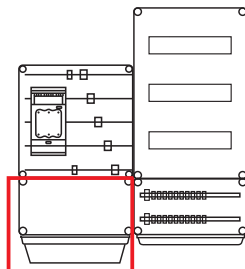

**Photovoltaic installations need special ratings.**

Why are special solutions needed for PV plants?

The rating of photovoltaic installations differs significantly from normal building installations in that the installed devices are subject to a continuous load.

**Protective device selection**

**Power distribution in buildings**

Protective device selection and rating to protect cables related to the current resp. the load of the consumer.

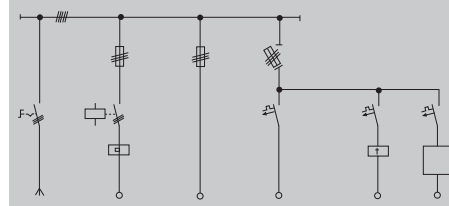

Select protective devices in the form of a fuse or miniature circuit breaker.

**Power distribution in photovoltaic plants**

Protective device selection and rating to protect cables related to the current resp. load of the solar inverter on the AC side.

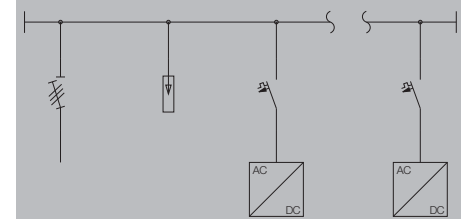

Select protective devices in the form of a fuse or miniature circuit breaker.

**Applying the simultaneity factor**

Due to the low simultaneity factor, the installed distribution board is often dimensioned according to the number of modules.

**PV plants have a simultaneity factor of 1!**  
Which is why the distribution boards in PV plants have to be dimensioned differently and not simply according to the number of modules.

**Influenced by heat from the simultaneity factor and load**

In consumption plants, power dissipation fluctuates depending on the number of consumers switched on at any one time.

**Low average effective power dissipation**

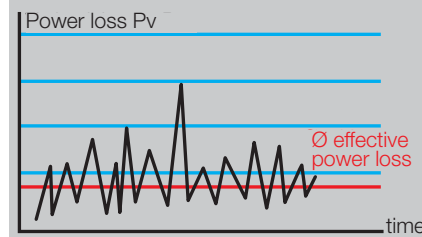

Constant high loads lead to high average power dissipation during the energy production phase.

Power dissipation therefore needs to be reduced to the point where the maximum temperature for devices is not exceeded.

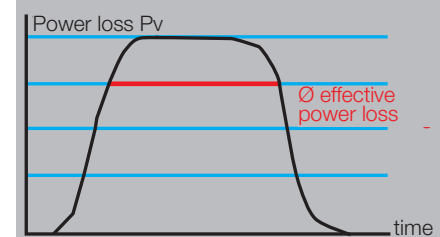

**Hensel solar inverter collectors correct dimensioned and tested: e.g. circuit-breaker box**

High power dissipation levels can lead to exceeding the maximum permitted temperature for devices meaning that protection devices can trip even when beneath rated current levels.

Photovoltaic installations require a special way of thinking about device dimensioning and selection!

The equipment of a circuit breaker box can be inferred from the following table.

**Table: Rating of solar inverter collector**

Protection device for 1~ solar inverter with 1-pole miniature circuit breakers (MCB)								*1 MU = 18 mm	
Inverter		miniature circuit breaker			cable		glands	flange	
maximum power output:	max. operating current	rated current	max. quantity	MU* between two MCB	minimum cable cross section	minimum outside diameter			
2,8 kVA	12 A	16 A	6 per row	1	3 x 2,5 mm <sup>2</sup>	11 mm	M 25	Mi FM 25	
3,7 kVA	16 A	20 A	5 per row	1	3 x 2,5 mm <sup>2</sup>	11 mm	M 25	Mi FM 25	
4,8 kVA	21 A	25 A	4 per row	1	3 x 4 mm <sup>2</sup>	13 mm	M 25	Mi FM 25	
6,5 kVA	28 A	32 A	3 per row	1	3 x 6 mm <sup>2</sup>	15 mm	M 25	Mi FM 25	

Protection device for 3~ solar inverter with 1-pole miniature circuit breakers (MCB)								*1 MU = 18 mm	
Inverter		miniature circuit breaker			cable		glands	flange	
maximum power output:	max. operating current	rated current	max. quantity	MU* between two MCB	minimum cable cross section	minimum outside diameter			
8,4 kVA	12 A	16 A	6 per row	1	5 x 2,5 mm <sup>2</sup>	13,5 mm	M 25	Mi FM 32	
11,1 kVA	16 A	20 A	5 per row	1	5 x 2,5 mm <sup>2</sup>	13,5 mm	M 25	Mi FM 32	
14,4 kVA	21 A	25 A	4 per row	1	5 x 4 mm <sup>2</sup>	15,5 mm	M 32	Mi FM 32	
19,5 kVA	28 A	32 A	3 per row	1	5 x 6 mm <sup>2</sup>	18 mm	M 32	Mi FM 32	

Protection device for 3~ solar inverter with 3-pole miniature circuit breakers (MCB)								*1 MU = 18 mm	
Inverter		miniature circuit breaker			cable		glands	flange	
maximum power output:	max. operating current	rated current	max. quantity	MU* between two MCB	minimum cable cross section	minimum outside diameter			
8,4 kVA	12 A	16 A	2 per row	6	5 x 2,5 mm <sup>2</sup>	13,5 mm	M 25	Mi FM 32	
8,9 kVA	13 A	20 A	2 per row	66	5 x 2,5 mm <sup>2</sup>	13,5 mm	M 25	Mi FM 32	
11,7 kVA	17 A	25 A	2 per row	12	5 x 4 mm <sup>2</sup>	15,5 mm	M 32	Mi FM 32	
14,4 kVA	21 A	25 A	1 per row		5 x 4 mm <sup>2</sup>	15,5 mm	M 32	Mi FM 32	
19,5 kVA	28 A	32 A	1 per row		5 x 6 mm <sup>2</sup>	18 mm	M 32	Mi FM 32	

Values are valid for max. ambient temperature of 35° C

**1. Assessing simultaneity and load capacity**



**High simultaneity and load:**

- Devices spaced apart allow a better radiation of the power dissipation.
- Additional slots assure increased air circulation in the enclosure.
- The larger enclosure increase the dissipated power loss.

**2. Standard assembly support**



- Installation devices are to be properly installed automatically with the help of spacers.



- At the same time the miniature circuit breaker is in the proper position relative to the cover plate.



**Mi PV 6111**

**Rated capacity: 70 kVA**

- complete enclosure set, not assembled
- incoming cables:
- for inverters up to 6.4 kVA, 1~ or 19.3 kVA, 3~  
rated operating current 28 A per inverter
- max. 18 x 1~ inverters or 6 x 3~ inverters
- Maximum quantity and ratings of MCBs according to table "Rating of PV solar inverter collector"
- connection: 1,5-16 mm<sup>2</sup>, Cu
- 18 terminals per PE+N
- Outgoing:
- switch disconnecter, 3 pole with knife links  
connection: 35 mm<sup>2</sup>, Cu  
1 terminal per PE+N for copper conductors
- outgoing cable changeable above or below
- maximum back-up fuse depending on the miniature circuit breakers used (manufacturer specifications)
- order cable entries separately
- with stainless steel external brackets

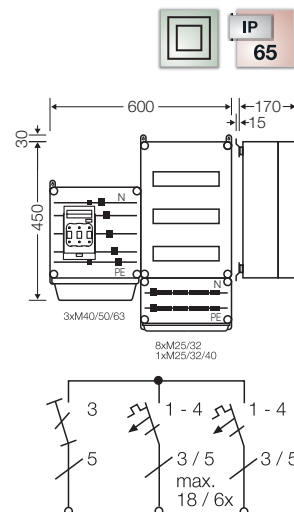

rated voltage	$U_n = 230/400 \text{ V a.c.}$
Rated current of the power switchgear and controlgear assembly	$I_{nA} = 100 \text{ A}$
rated short-time withstand current	$I_{cw} = 15 \text{ kA} / 1 \text{ s}$ with fuse links



**Mi PV 6123**

**Rated capacity: 140 kVA**

- complete enclosure set, not assembled
- incoming cables:
- for inverters up to 6.4 kVA, 1~ or 19.3 kVA, 3~  
rated operating current 28 A per inverter
- max. 36 x 1~ inverters or 12 x 3~ inverters
- Maximum quantity and ratings of MCBs according to table "Rating of PV solar inverter collector"
- connection: 1,5-16 mm<sup>2</sup>, Cu
- 36 terminals per PE+N
- Outgoing:
- switch disconnecter, 3 pole with knife links  
connection: M 10 (max. 1 x 240 mm<sup>2</sup> per phase)  
1 terminal per PE+N for copper conductors
- outgoing cable changeable above or below
- order cable entries separately
- with stainless steel external brackets

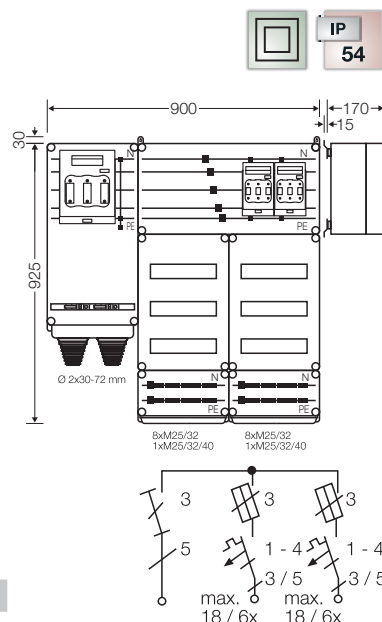

rated voltage	$U_n = 230/400 \text{ V a.c.}$
Rated current of the power switchgear and controlgear assembly	$I_{nA} = 200 \text{ A}$
rated short-time withstand current	$I_{cw} = 15 \text{ kA} / 1 \text{ s}$ with fuse links



**Mi PV 6544**

**Rated capacity: 220 kVA**

- complete enclosure set, not assembled
- incoming cables:
- for inverters up to 6.4 kVA, 1~ or 19.3 kVA, 3~  
rated operating current 28 A per inverter
- max. 72 x 1~ inverters or 24 x 3~ inverters
- Maximum quantity and ratings of MCBs according to  
table "Rating of PV solar inverter collector"
- connection: 1,5-16 mm<sup>2</sup>, Cu
- 72 terminals per PE+N
- Outgoing:
- switch disconnecter, 3 pole with knife links  
connection: M 10 (max. 1 x 240 mm<sup>2</sup> per phase)  
1 terminal per PE+N for copper conductors
- outgoing cable changeable above or below
- order cable entries separately
- with mounting profiles

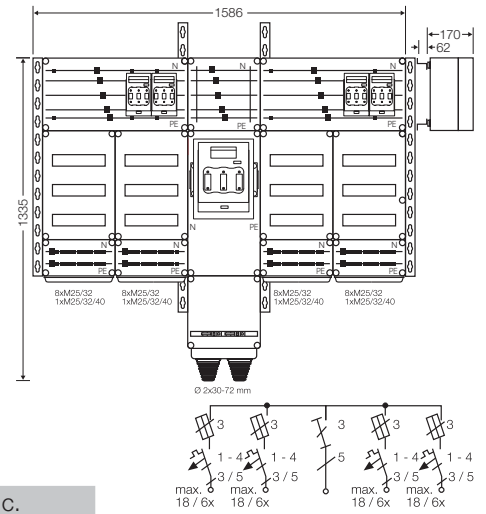

rated voltage	$U_n = 230/400 \text{ V a.c.}$
Rated current of the power switchgear and controlgear assembly	$I_{nA} = 320 \text{ A}$
rated short-time withstand current	$I_{cw} = 15 \text{ kA} / 1 \text{ s}$ with fuse links

Extension boxes for solar inverter collectors, see accessories



Mi PV 5611  
Surge protection device box (SPD)



Mi PV 5621  
Surge protection device box (SPD)



Mi PV 5711  
12 modules: 1 x 12 x 18 mm



**Mi PV 5311**

**Rated capacity: 70 kVA  
for 3~ inverters**

- complete enclosure set, not assembled
- incoming cables:
- for inverters up to 33 kVA, 3~  
rated operating current AC 48 A per inverter
- 3 x 63 A, 3-pole, D0 2  
1 or 3-pole switching  
rated connecting capacity: solid(sol) 1.5-6 mm<sup>2</sup>, flexible(f)  
1.5-16 mm<sup>2</sup>, Cu
- 3 terminals per PE+N
- Outgoing:
- switch disconnector, 3 pole with knife links  
connection: 70 mm<sup>2</sup>, Cu  
1 terminal per PE+N for copper conductors
- outgoing cable changeable above or below
- order cable entries separately
- with stainless steel external brackets

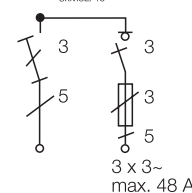
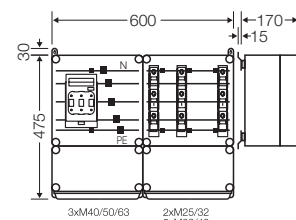

rated voltage	$U_n = 230/400 \text{ V a.c.}$
Rated current of the power switchgear and controlgear assembly	$I_{nA} = 100 \text{ A}$
rated current of a circuit	$I_{nc} = 48 \text{ A}$
RDF (Rated Diversity Factor)	1
rated short-time withstand current	$I_{cw} = 15 \text{ kA} / 1 \text{ s}$ with fuse links



**Mi PV 5323**

**Rated capacity: 140 kVA  
for 3~ inverters**

- complete enclosure set, not assembled
- incoming cables:
- for inverters up to 33 kVA, 3~  
rated operating current AC 48 A per inverter
- 6 x 63 A, 3-pole D0 2  
1- or 3-pole switching  
rated connecting capacity: solid (sol) 1.5-6 mm<sup>2</sup>, flexible (f)  
1.5-16 mm<sup>2</sup>, Cu
- 6 terminals per PE+N
- Outgoing:
- switch disconnector, 3 pole with knife links  
connection: M 10 (max. 1 x 240 mm<sup>2</sup> per phase)  
1 terminal per PE+N for copper conductors
- outgoing cable changeable above or below
- order cable entries separately
- with stainless steel external brackets

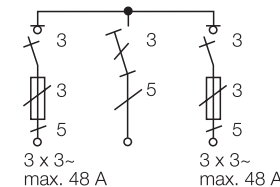
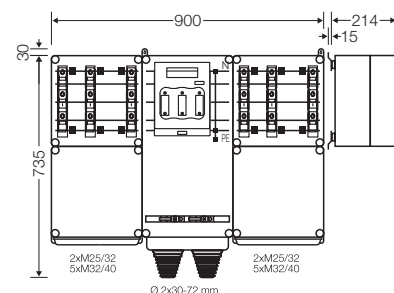

rated voltage	$U_n = 230/400 \text{ V a.c.}$
Rated current of the power switchgear and controlgear assembly	$I_{nA} = 200 \text{ A}$
rated current of a circuit	$I_{nc} = 48 \text{ A}$
RDF (Rated Diversity Factor)	1
rated short-time withstand current	$I_{cw} = 15 \text{ kA} / 1 \text{ s}$ with fuse links

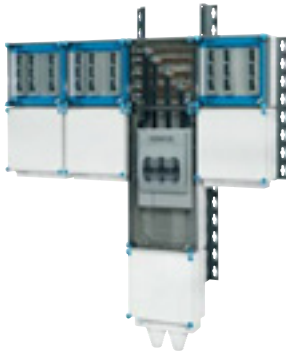

**Mi PV 5341**  
**Rated capacity: 220 kVA**  
**for 3~ inverters**

- complete enclosure set, not assembled
- incoming cables:
- for inverters up to 33 kVA, 3~  
rated operating current AC 48 A per inverter
- 9 x 63 A, 3-pole D0 2  
1- or 3-pole switching  
rated connecting capacity: solid (sol) 1.5-6 mm<sup>2</sup>, flexible (f)  
1.5-16 mm<sup>2</sup>, Cu
- 9 terminals per PE+N
- Outgoing:
- switch disconnector, 3 pole with knife links  
connection: M 10 (max. 1 x 240 mm<sup>2</sup> per phase)  
1 terminal per PE+N for copper conductors
- outgoing cable changeable above or below
- order cable entries separately
- with mounting profiles

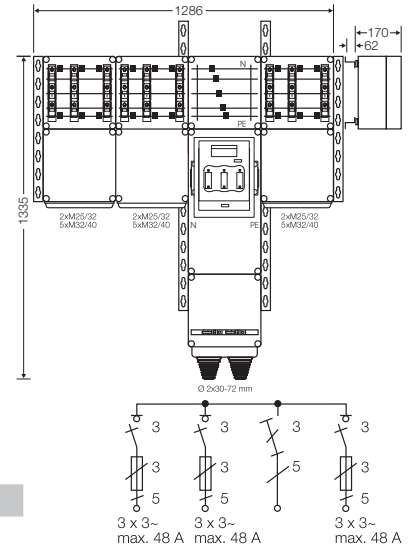

rated voltage	$U_n = 230/400 \text{ V a.c.}$
Rated current of the power switchgear and controlgear assembly	$I_{nA} = 320 \text{ A}$
rated current of a circuit	$I_{nc} = 48 \text{ A}$
RDF (Rated Diversity Factor)	1
rated short-time withstand current	$I_{cw} = 15 \text{ kA} / 1 \text{ s}$ with fuse links

Extension boxes for solar inverter collectors, see accessories



Mi PV 5611  
Surge protection device  
box (SPD)



Mi PV 5621  
Surge protection device  
box (SPD)



Mi PV 5711  
12 modules: 1 x 12 x 18  
mm



**Mi PV 1318**

**18 modules: 3 x 6 x 18 mm  
without PE and N terminal**

- 3-row
- for installation of DIN rail equipment in accordance with DIN 43880
- Maximum quantity and ratings of MCBs and flange selection according to table "Rating of PV solar inverter collector"
- with blanking strips for unused DIN rail openings
- lid fasteners for hand operation

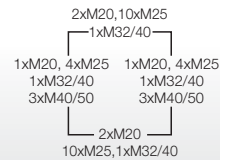
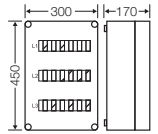

**Mi 1335**

**36 modules: 3 x 12 x 18 mm  
without PE and N terminal**

- 3-row
- for installation of DIN rail equipment in accordance with DIN 43880
- order PE/N terminals separately
- with blanking strips for unused DIN rail openings
- lid fasteners for hand operation

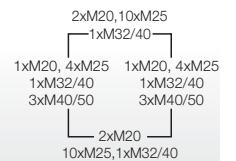
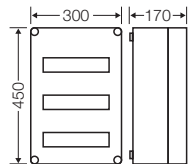

More empty enclosures or enclosures with electrical function:



Mi Distribution boards



**Mi 3266**

**with switch disconnectors with fuses**  
**Rated current of busbars 250 A**  
**only for combination**

- 3 x 63 A, 3-pole, D0 2  
1 or 3-pole switching  
rated connecting capacity: solid(sol) 1.5-6 mm<sup>2</sup>, flexible(f) 1.5-16 mm<sup>2</sup>, Cu
- per PE and N terminal: 3 x 1.5-16 mm<sup>2</sup>, Cu, round conductors
- without supply cable
- N conductor with the same current carrying capacity as the phase conductors
- lid fasteners for hand operation

rated voltage of the device	$U_n = 400 \text{ V a.c.}$
rated current of the device	63 A
rated current of a circuit	$I_{nc} = 50.4 \text{ A}$ for design verification of permissible temperature rise according to IEC 61439-1, Section 10.10.4
number of circuits	3
rated short-time withstand current	$I_{cw} = 15 \text{ kA} / 1 \text{ s}$
busbar system - polarity	5
busbar thickness	L1-L3: 10 mm N, PE: 5 mm
centreline spacing of busbars	60 mm

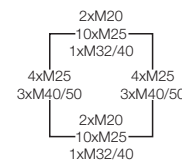
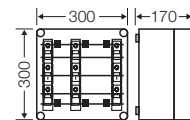

**Mi 3267**

**with switch disconnectors with fuses**  
**Rated current of busbars 400 A**  
**only for combination**

- 3 x 63 A, 3-pole, D0 2  
1 or 3-pole switching  
rated connecting capacity: solid(sol) 1.5-6 mm<sup>2</sup>, flexible(f) 1.5-16 mm<sup>2</sup>, Cu
- per PE and N terminal: 3 x 1.5-16 mm<sup>2</sup>, Cu, round conductors
- without supply cable
- N conductor with the same current carrying capacity as the phase conductors
- lid fasteners for hand operation

rated voltage of the device	$U_n = 400 \text{ V a.c.}$
rated current of the device	63 A
rated current of a circuit	$I_{nc} = 50.4 \text{ A}$ for design verification of permissible temperature rise according to IEC 61439-1, Section 10.10.4
number of circuits	3
rated short-time withstand current	$I_{cw} = 15 \text{ kA} / 1 \text{ s}$
busbar system - polarity	5
busbar thickness	L1-L3, N: 10 mm PE: 5 mm
centreline spacing of busbars	60 mm

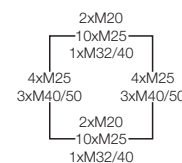
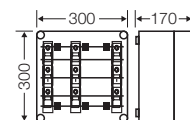



**Mi PV 5511**

**Terminal box**

- extension set
- ready for connection
- with wall gasket
- per PE+N 12 x 1.5-16 mm<sup>2</sup>, Cu, 1 x 4-35 mm<sup>2</sup>, Cu
- with 100 A wiring between PE+N terminals and busbar
- lid fasteners for tool operation
- Separately order flange for cable entry.

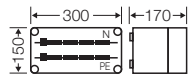

rated voltage  $U_n = 230/400$  V a.c.

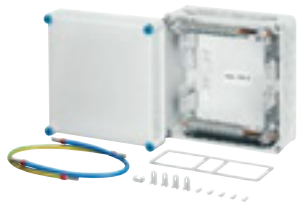

**Mi PV 5521**

**Terminal box**

- extension set
- ready for connection
- with wall gasket
- terminals per PE+N:  
9 x 1.5-16 mm<sup>2</sup>, Cu  
1 x 4-35 mm<sup>2</sup>, Cu
- with 100 A wiring between PE+N terminals and busbar
- lid fasteners for tool operation
- Separately order flange for cable entry.

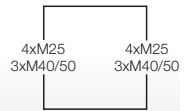
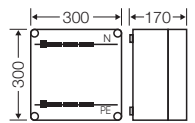

rated voltage  $U_n = 230/400$  V a.c.

More empty enclosures or enclosures with electrical function:



Mi Distribution boards

Photovoltaik

Solar inverter collectors **up to 560 kVA**  
made of insulation material, protection class II,  
degree of protection up to IP 65

**Customised solutions?  
Contact us!**



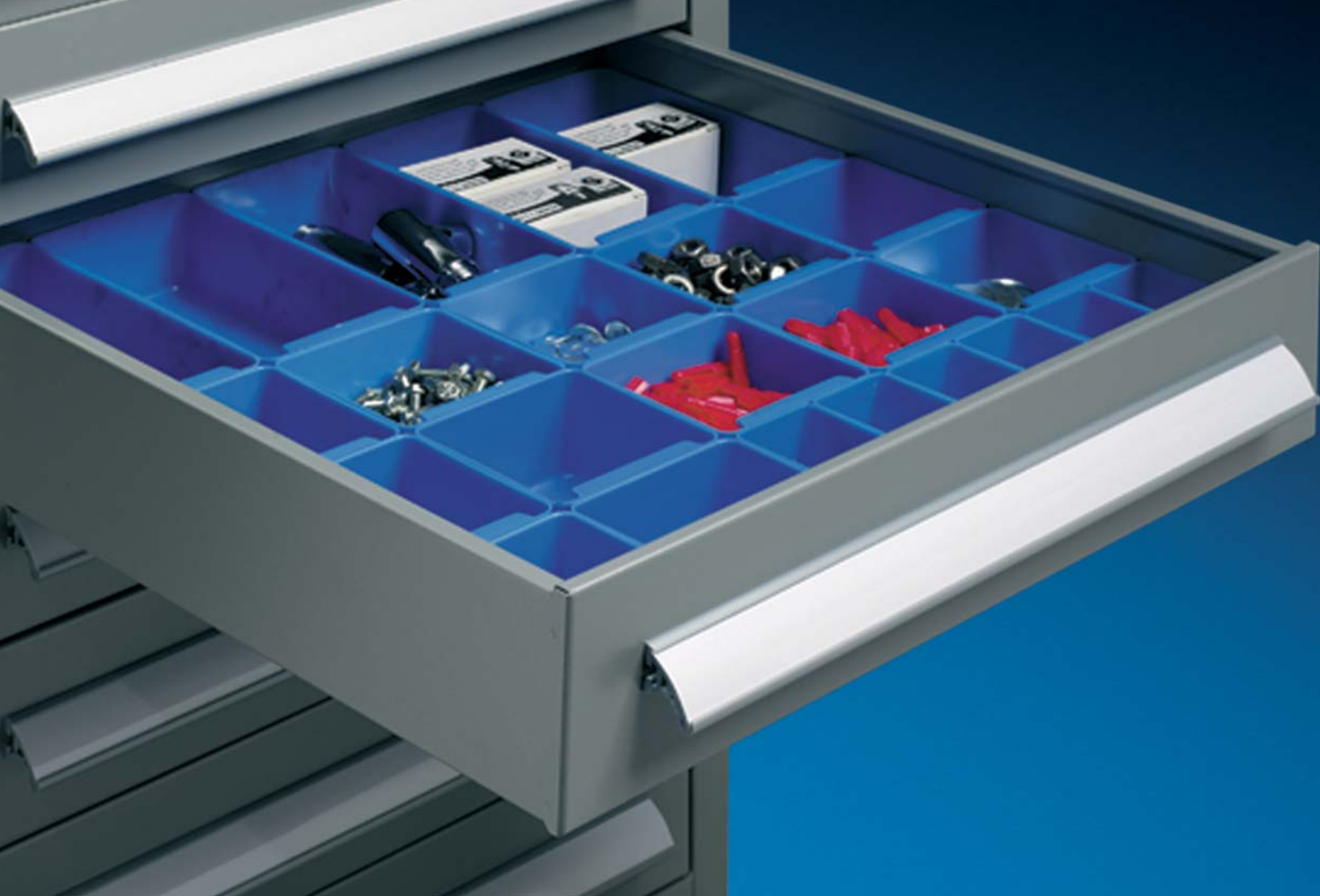

**ENYSUN**

**Accessories**

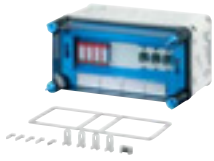

**Mi PV 5611**

**Surge protection device box (SPD)  
1 x AC type 2 surge arrester**

- extension set
- with wall gasket
- with pre-assembled connecting cables
- with terminals for direct connection on busbar
- with fuse bases 63 A, Neozed
- 1 x AC type 2 surge arrester  
max. outgoing surge current AC (8/20)  $I_{total}$ : 40 kA  
protection level AC: < 2,5 kV  
defect display
- for 3-phase TN
- lid fasteners for hand operation
- Connection

rated voltage  $U_n = 230/400$  V a.c.

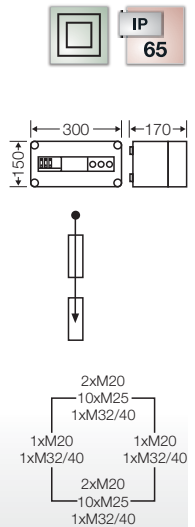

**Mi PV 5621**

**Surge protection device box (SPD)  
1 x AC type 1 surge arrester**

- extension set
- with wall gasket
- with pre-assembled connecting cables
- with fuse switch disconnectors HRC 00, 3-pole  
with fuse links 3 x 160 A
- AC type 1 surge arrester  
lightning surge current AC(10/350) [L+N -> PE]  $I_{imp}$ : 100 kA  
protection level AC: < 4 kV  
defect display
- for 3-phase TN
- lid fastener for tool operation
- Connection

rated voltage  $U_n = 230/400$  V a.c.

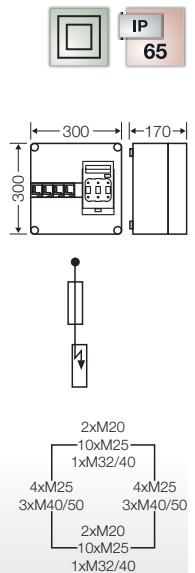

**Mi PV 5711**

**12 modules: 1 x 12 x 18 mm**

- 1-row
- without PE and N terminal
- for installation of DIN rail equipment in accordance with DIN 43880
- with blanking strips for unused DIN rail openings
- with wall gasket
- lid fasteners for hand operation

rated voltage  $U_n = 230/400$  V a.c.

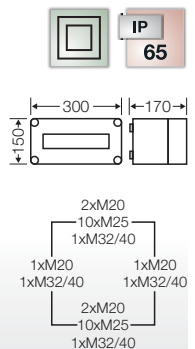



**DA 240**

**Terminal for direct connection up to 400 A  
max. 240 mm<sup>2</sup>**

- for mounting onto switchgear with flat contact M10
- with insulating cover
- rated connecting capacity:
  - 35-70 mm<sup>2</sup> s (round), Cu/Alu
  - 50-185 mm<sup>2</sup> s (sector), Cu/Alu
  - 35-50 mm<sup>2</sup> sol, Cu/Alu
  - 70-240 mm<sup>2</sup> sol (sector) Cu/Alu
- Before connecting, aluminum conductors must be pre-treated according to the appropriate technical recommendations, see technical information aluminum conductors

tightening torque for terminal	22,0 Nm
--------------------------------	---------



**MS NH 00**

**Fuse switch disconnecter 160 A, HRC 00, 3-pole  
for retrofitting on busbars**

- for the exchange and complement in Mi fuse boxes
- height: 200 mm x width: 106 mm
- Connection: 1.5-70 mm<sup>2</sup>, Cu, round conductor  
Connection of wiring strip Mi VS 100/160

rated voltage	U <sub>n</sub> = 690 V a.c.
busbar thickness	10 mm
centreline spacing of busbars	60 mm
tightening torque for terminal	terminal 6.0 Nm



**Mi SP 18**

**switch disconnecter with fuses D02  
63 A, 3-pole, D0 2**

- for the exchange and complement in Mi fuse boxes
- 1 or 3-pole switching
- rated connecting capacity: solid(sol) 1.5-6 mm<sup>2</sup>, flexible(f) 1.5-16 mm<sup>2</sup>, Cu
- width: 27 mm

rated voltage	U <sub>n</sub> = 400 V a.c.
busbar thickness	10 mm
centreline spacing of busbars	60 mm
tightening torque for terminal	3.0 Nm



**Mi BA 6**

**blanking cover  
in Mi-HRC fuse boxes**

- for sealing protection covers
- Width: 108 mm



**Mi WD 2**

**Wall gasket  
for box walls 150/300 mm**

- for the assembly of Mi boxes
- consisting of 1 seal, 4 wedge links, 1 bracket

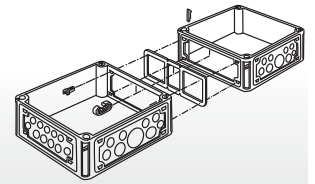

**Mi SV 25**

**Busbar connector  
for busbars 250 A, 5-pole**

- with wall gasket
- for the assembly of Mi boxes containing busbars
- Busbars 250 A and 400 A can only be connected with busbar connector Mi SV 25. Connecting of busbars with different rated current only under care and attention of the corresponding short circuit and overload standards.

tightening torque for terminal	6.0 Nm
--------------------------------	--------

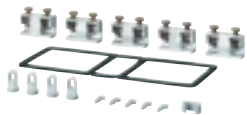

**Mi SV 45**

**Busbar connector  
for busbars 400/630 A, 5-pole**

- with wall gasket
- for the assembly of Mi boxes containing busbars

tightening torque for terminal	10.0 Nm
--------------------------------	---------



**AS 12**

**Blanking strip  
12 modules**

- 12 x 18 mm, divisible every 9 mm
- for the covering of spare equipment openings, for material thickness up to 3 mm



**DAE 12**

**Spacer**

- to improve the heat dissipation of DIN rail mounted devices
- consisting of 12 items



**Mi FM 25**

**Flange**  
**knockouts: 19 x M 16/25**

- box wall 300 mm
- with fixing wedges and seal

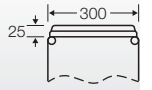

**Mi FM 32**

**Flange**  
**knockouts: 8 x M 25/32, 1 x M 25/32/40**

- box wall 300 mm
- with fixing wedges and seal

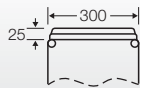

**Mi FM 40**

**Flange**  
**knockouts: 2 x M 25/32, 5 x M 32/40**

- box wall 300 mm
- with fixing wedges and seal

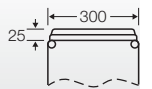

**Mi FM 50**

**Flange**  
**knockouts: 2 x M 20, 4 x M 32/40/50**

- box wall 300 mm
- with fixing wedges and seal

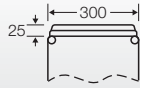

**Mi FM 60**

**Flange**  
**knockouts: 3 x M 40/50/63**

- box wall 300 mm
- with fixing wedges and seal

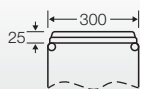

**Mi FP 70**

**Flange**  
**sealing range: 1 x Ø 30-72 mm**

- box wall 300 mm
- with fixing wedges and seal

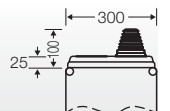

**Mi FP 72**

**Flange**  
**sealing range: 2 x each Ø 30-72 mm**

- box wall 300 mm
- with fixing wedges and seal

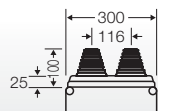



**Mi FM 63**

**Flange with cable arrangement space  
knockouts: 3 x M 40/50/63**

- box wall 300 mm
- with fixing wedges and seal

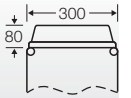

**Mi FP 82**

**Cable insert  
sealing range: 2 x each Ø 30-72 mm**

- box wall 300 mm
- divisible for cable insertion from the front
- degree of protection IP 54 only with additional strain and pressure relief (e.g. Mi ZE 62)

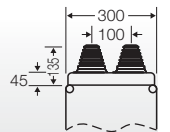

**Mi ZE 62**

**Cable strain relief  
for 2 cables with max. 60 mm external diameter**

- with fixing rail 284 mm long
- to be used only in connection with cable insertion Mi FP 82



**AKM 12**  
**Cable glands**  
**for knockouts M 12**



- sealing range: Ø 4-6 mm
- ISO thread M 12 x 1.5
- bore-hole: Ø 12.3 mm
- wall thickness up to 3 mm
- with strain relief and locknut
- for indoor (normal environment and/or protected outdoor) and outdoor installation (harsh environment and/or outdoor)
- ambient temperature - 25 °C to + 55 °C
- glow wire test IEC 60695-2-11: 960 °C
- colour: grey, RAL 7035



tightening torque	0,9 Nm
-------------------	--------



**AKM 16**  
**Cable glands**  
**for knockouts M 16**



- sealing range: Ø 5-10 mm
- ISO thread M 16 x 1.5
- bore-hole: Ø 16.3 mm
- wall thickness up to 3 mm
- with strain relief and locknut
- for indoor (normal environment and/or protected outdoor) and outdoor installation (harsh environment and/or outdoor)
- ambient temperature - 25 °C to + 55 °C
- glow wire test IEC 60695-2-11: 960 °C
- colour: grey, RAL 7035



tightening torque	3,0 Nm
-------------------	--------



**AKM 20**  
**Cable glands**  
**for knockouts M 20**



- sealing range Ø 6,5-13,5 mm
- ISO thread M 20 x 1.5
- bore-hole: Ø 20.3 mm
- wall thickness up to 3 mm
- with strain relief and locknut
- for indoor (normal environment and/or protected outdoor) and outdoor installation (harsh environment and/or outdoor)
- ambient temperature - 25 °C to + 55 °C
- glow wire test IEC 60695-2-11: 960 °C
- colour: grey, RAL 7035



tightening torque	4,0 Nm
-------------------	--------



### AKM 25

#### Cable glands for knockouts M 25

- sealing range  $\varnothing$  11-17 mm
- ISO thread M 25 x 1.5
- bore-hole:  $\varnothing$  25.3 mm
- wall thickness up to 3 mm
- with strain relief and locknut
- for indoor (normal environment and/or protected outdoor) and outdoor installation (harsh environment and/or outdoor)
- ambient temperature - 25 °C to + 55 °C
- glow wire test IEC 60695-2-11: 960 °C
- colour: grey, RAL 7035

tightening torque

7,5 Nm



### AKM 32

#### Cable glands for knockouts M 32

- sealing range  $\varnothing$  15-21 mm
- ISO thread M 32 x 1.5
- bore-hole:  $\varnothing$  32.3 mm
- wall thickness up to 3 mm
- with strain relief and locknut
- for indoor (normal environment and/or protected outdoor) and outdoor installation (harsh environment and/or outdoor)
- ambient temperature - 25 °C to + 55 °C
- glow wire test IEC 60695-2-11: 960 °C
- colour: grey, RAL 7035

tightening torque

10,0 Nm



### AKM 40

#### Cable glands for knockouts M 40

- sealing range:  $\varnothing$  19-28 mm
- ISO thread M 40 x 1.5
- bore-hole:  $\varnothing$  40.3 mm
- wall thickness up to 3 mm
- with strain relief and locknut
- for indoor (normal environment and/or protected outdoor) and outdoor installation (harsh environment and/or outdoor)
- ambient temperature - 25 °C to + 55 °C
- glow wire test IEC 60695-2-11: 960 °C
- colour: grey, RAL 7035

tightening torque

10,0 Nm





### AKM 50

#### Cable glands for knockouts M 50

- sealing range: Ø 27-35 mm
- ISO thread M 50 x 1.5
- bore-hole: Ø 50.3 mm
- wall thickness up to 3 mm
- with strain relief and locknut
- for indoor (normal environment and/or protected outdoor) and outdoor installation (harsh environment and/or outdoor)
- ambient temperature - 25 °C to + 55 °C
- glow wire test IEC 60695-2-11: 960 °C
- colour: grey, RAL 7035



tightening torque	10,0 Nm
-------------------	---------



### AKM 63

#### Cable glands for knockouts M 63

- sealing range: Ø 35-42 mm
- ISO thread M 63 x 1.5
- bore-hole: Ø 63.3 mm
- wall thickness up to 3 mm
- with strain relief and locknut
- for indoor (normal environment and/or protected outdoor) and outdoor installation (harsh environment and/or outdoor)
- ambient temperature - 25 °C to + 55 °C
- glow wire test IEC 60695-2-11: 960 °C
- colour: grey, RAL 7035



tightening torque	10,0 Nm
-------------------	---------



**Mi BF 44**

**Ventilation flange  
for vertical installation on box walls**



- box wall 300 mm
- for ventilation of Mi-Distribution boards in the event of extremely high internal temperatures or a risk of water condensation



**BE 44**

**Ventilation insert**



**BM 20G**

**Pressure compensation element for M 20 knockouts**



- for the reduction of condensation by pressure compensation in power distribution systems
- ISO thread M 20 x 1.5
- bore-hole: Ø 20.3 mm
- wall thickness up to 4 mm
- with counter nut
- for indoor (normal environment and/or protected outdoor) and outdoor installation (harsh environment and/or outdoor)
- ambient temperature - 25 °C to + 55 °C
- In order not to exceed leakage limit of 0.07 bar with pressure compensation, one pressure compensation element BM 20G must be used per 28 litres (28000 cm³) of enclosure volume.
- Example: enclosure size 30 cm x 60 cm x 17 cm = 30600 cm³ = 30,6 litres. Number of necessary BM 20G (M20) = 2 piece.
- technical changes reserved
- colour: grey, RAL 7035

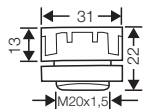

**BM 40G**

**Pressure compensation element for M 40 knockouts**



- for the reduction of condensation by pressure compensation in power distribution systems
- ISO thread M 40 x 1.5
- bore-hole: Ø 40.3 mm
- wall thickness of up to 8 mm
- with counter nut
- for indoor (normal environment and/or protected outdoor) and outdoor installation (harsh environment and/or outdoor)
- ambient temperature - 25 °C to + 55 °C
- In order not to exceed leakage limit of 0.07 bar with pressure compensation, one pressure compensation element BM 40G must be used per 122 litres (122000 cm³) of enclosure volume.
- Example: enclosure size 60 cm x 60 cm x 17 cm = 61200 cm³ = 61,2 litres. Number of necessary BM 40G (M40) = 1 piece.
- technical changes reserved
- colour: grey, RAL 7035

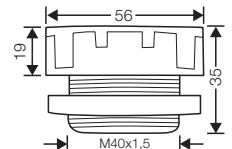

Pressure compensation element



**Mi DB 15**  
**Canopy**  
**for box wall 150 mm**

- with fixing wedges and seal
- suitable for outdoor installation, UV resistant



material	stainless steel powder-coated
----------	----------------------------------

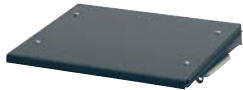

**Mi DB 30**  
**Canopy**  
**for 300 mm box walls**

- with fixing wedges and seal
- suitable for outdoor installation, UV resistant



material	stainless steel powder-coated
----------	----------------------------------

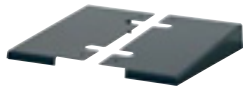

**Mi DB 01**  
**Canopy end plate**

- for canopies FP DB xx and Mi DB xx

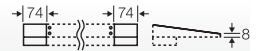

material	stainless steel powder-coated
----------	----------------------------------

Canopy





**Mi PL 2**

**Sealing cap**

- 2 sealing caps for converting the lid fasteners



**Mi SR 4**

**Conversion set  
for hand operation on tool operation**

- 4 fastening covers



**Mi SN 4**

**Conversion set  
for converting lid fasteners from tool to manual operation**

- 4 manual actuators



**Mi DV 01**

**Locking device insertion**

- only in connection with Mi PL 2, Mi SR 4 or Mi SN 4



**Mi ZS 11**

**Lid lock  
with locking device I  
for Mi boxes sizes 1 to 6**

- can be used instead of fasteners for hand or tool operation in order to prevent unauthorised opening of the lids
- consisting of: cylinder lock, keys, locking device insertion, dust cover



**Mi ZS 12**

**Lid lock  
with locking device II  
for Mi boxes sizes 1 to 6**

- can be used instead of fasteners for hand or tool operation in order to prevent unauthorised opening of the lids
- consisting of: cylinder lock, keys, locking device insertion, dust cover



**Mi DR 04**

**lid fastener for tool operation  
triangle 8 mm**

- is being used in place of fasteners for hand- or tool operation to prevent unauthorized opening of lids
- 4 locking devices with triangle 8 mm and key



**DS 1**

**Triangular key 8 mm**



**Mi SA 2**

**Dust protection cover**

- for box sizes 1 to 6
- for 2 lid fittings



**Mi AL 40**  
**4 stainless steel external brackets**

- for external fixing of enclosures

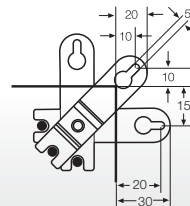

**Mi MS 2**  
**Profile for wall mounting**

- for Mi distribution board assemblies up to 900 x 1200 mm
- with 8 screws M6 x 16, washers and nuts for mounting enclosures

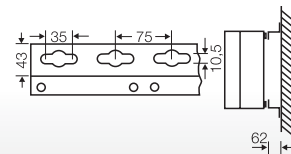

length	1950 mm
material	sendzimir galvanised steel profile with structured powder coating



**ENYSUN**

Technical Data

Products	Material used	Glow wire test IEC 60695-2-11	UL Subject 94	Temperature resistance	Chemical resistance <sup>1)</sup>					
					Acid 10 %	Lye 10 %	Alcohol	Petrol (MAK) <sup>2)</sup>	Benzene (MAK) <sup>2)</sup>	Minerar oil
<b>bases of Mi ...</b>	PC (polycarbonate) (with GFS)	960 °C	V-0	-40 °C / +120 °C	+	+	0	+	—	+
<b>lid Mi ... door and lid KV ... /</b>	PC (polycarbonate)	960 °C	V-0	-40 °C / +120 °C	+	+	0	+	—	+
<b>Sealings KV ... / Mi FP ...</b>	TPE (thermoplastic elastomer)	750 °C	—	-25 °C / +100 °C	+	+	+	0	0	0
<b>Sealings KV ... / Mi ...</b>	PUR (polyurethane)	—	—	-25 °C / +80 °C	0	+	0	0	—	+
<b>AKM .. / BM ...</b>	PA (polyamide)	960 °C	V-0	-40 °C / +100 °C	+	0	+	+	+	+
<b>Sealings AKM ..</b>	CR/NBR (polychloroprene - nitrile rubber)	—	—	-20 °C / +100 °C	+	+	+	0	—	0

As at: January 2018

(+ = resistance; 0 = partially resistance; — = not resistant)

1) The specifications on chemical resistance are a general guide. In individual cases it may be necessary to check resistance in combination with other chemicals and ambient conditions (temperature, concentration, etc.)

2) (MAK) - Maximum allowable concentration (work place)

	KV PV..., Mi PV..	Cable glands
		AKM
<b>Application area</b>	<b>Suitable for indoor installation and outdoor installation, protected against weather influences</b> However, pay attention to the climatic effects on the installed equipment , for example, high or low ambient temperatures or formation of condensed water see technical information	
<b>Ambient temperature</b>		
- Average value over 24 hours	+ 35 °C	+ 55 °C
- Maximum value	+ 40 °C	+ 70 °C
- Minimum value	- 5 °C	- 25 °C
<b>Relative humidity</b>	50% at 40 °C	
- short-time	100% at 25 °C	
<b>Fire protection</b> in the event of internal faults	Demands placed on electrical devices from standards and laws  Minimum requirements - Glow wire test in accordance with IEC 60695-2-11: - 650° C for boxes and cable glands - 850° C for conducting components	
<b>Burning behaviour</b>		
- Glow wire test IEC 60 695-2-11	960 °C	750 °C
- UL Subject 94	V-2 flame-retardant self-extinguishing	V-0 flame-retardant self-extinguishing
<b>Degree of protection against mechanical load</b>	IK 08 (5 Joule)	
<b>Toxic behaviour</b>	halogen-free <sup>1)</sup> silicone-free	

<sup>1)</sup> "Halogen-free" in accordance with IEC 754-2 "Common test methods for cables - Determination of the amount of halogen acid gas".

**Generator junction boxes  
and solar inverter collector  
comply with the require-  
ments of the IEC 61439 part  
1 and part 2**

Distribution boards assembled and wired according to manufacturer data without essential deviations from the original type or system.

To meet these requirements for Hensel Mi Distribution Boards, the following must be noted:

1. The distribution boards must consist of the verified enclosures documented in this list.
2. The wiring of the equipment must be carried out with the cross-sections and conductor types indicated in Table "Rating of insulated conductors in switchgear assemblies", Index Techniques.
3. Once the distribution board is completed, a routine test must be carried out in accordance with this standard.
4. The test must be certified with a test report.
5. The assembly must be provided with a manufacturer's identification mark.  
Compliance with important data such as
  - limit of temperature rise
  - dielectric strength
  - IP degrees of protection
  - creepage distances and clearances
 is verified for this system.

**Standards and regulations**

- IEC 61439-1  
Low voltage switchgear and controlgear assemblies
- IEC 60999  
Safety requirements for screw-type and screwless-type clamping units for electrical copper conductors
- DIN EN 50262  
Metric threaded cable glands for electrical installations
- IEC 60269  
Low voltage fuses
- DIN 43880  
Built-in equipment for electrical installations;  
overall dimensions and related mounting dimensions
- IEC 60529  
Degrees of protection provided by enclosures (IP-Code)
- IEC 60364-7-712  
Electrical installations of buildings  
Requirements for special installations or locations –  
Solar photovoltaic (PV) power supply systems

Technical Data

Outside Diameter of Conventional Cable Cross Sections

Short Forms of Cables

The outside diameters are average values of different products.

Cable cross-section	NYM	NYY	NYCY NYCWY
mm <sup>2</sup>	mm Ø	mm Ø	mm Ø
1x4	8	9	—
1x6	8.5	10	—
1x10	9.5	10.5	—
1x16	11	12	—
1x25	—	14	—
1x35	—	15	—
1x50	—	16.5	—
1x70	—	18	—
1x95	—	20	—
1x120	—	21	—
1x150	—	23	—
1x185	—	25	—
1x240	—	28	—
1x300	—	30	—
2x1.5	10	12	—
2x2.5	11	13	—
2x4	—	15	—
2x6	—	16	—
2x10	—	18	—
2x16	—	20	—
2x25	—	—	—
2x35	—	—	—
3x1.5	10.5	12.5	13
3x2.5	11	13	14
3x4	13	16	16
3x6	15	17	17
3x10	18	19	18
3x16	20	21	21
3x25	—	26	—
3x35	—	—	—
3x50	—	—	—
3x70	—	—	—
3x95	—	—	—
3x120	—	—	—
3x150	—	—	—
3x185	—	—	—
3x240	—	—	—
3x25/16	—	27	27
3x35/16	—	28	27
3x50/25	—	32	32
3x70/35	—	32-36	36
3x95/50	—	37-41	40
3x120/70	—	42	43
3x150/70	—	46	47
3x185/95	—	52	48-54
3x240/120	—	57-63	60
3x300/150	—	63-69	—

Cable cross-section	NYM	NYY	NYCY NYCWY
mm <sup>2</sup>	mm Ø	mm Ø	mm Ø
4x1.5	11	13.5	14
4x2.5	12.5	14.5	15
4x4	14.5	17.5	17
4x6	16.5	18	18
4x10	18.5	20	20
4x16	23.5	23	23
4x25	28.5	28	28
4x35	32	26-30	29
4x50	—	30-35	34
4x70	—	34-40	37
4x95	—	38-45	42
4x120	—	42-50	47
4x150	—	46-53	52
4x185	—	53-60	60
4x240	—	59-71	70
4x25/16	—	—	30
4x35/16	—	—	30
4x50/25	—	—	34-37
4x70/35	—	—	40
4x95/50	—	—	44.5
4x120/70	—	—	48.5
4x150/70	—	—	53
4x185/95	—	—	—
4x240/120	—	—	—
5x1.5	12	15	15
5x2.5	13.5	16	17
5x4	15.5	16.5	18
5x6	18	19	20
5x10	20	21	—
5x16	26	24	—
5x25	31.5	—	—
7x1.5	13	16	—
7x2.5	14.5	16.5	—
19x1.5	—	22	—
24x1.5	—	25	—

Short forms of cables

- NYM Light plastic-sheathed cable
- NYY Plastic-sheathed cable
- NYCY Plastic-sheathed cable with concentric conductor
- NYCWY Plastic-sheathed cable with concentric undulated conductor

Technical Data

Assignment of Cable Outside Diameters to Cable Entries Standards and Requirements



Outside diameter of cables		Cable entry metric
min. mm Ø	max. mm Ø	
3	6.5	AKM/ASS 12
5	10	AKM/ASS 16
6.5	13.5	AKM/ASS 20
10	17	AKM/ASS 25
14	21	AKM/ASS 32
20	28	AKM/ASS 40
25	35	AKM/ASS 50
35	48	AKM/ASS 63
5	10	AFM 16
8	13	AFM 20
11	17	AFM 25
15	21	AFM 32

**Cable glands AKM/ASS**

Degree of protection: up to IP 67  
With strain relief and counternut.

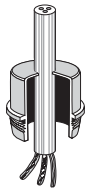

Outside diameter of cables		Cable entry metric
min. mm Ø	max. mm Ø	
4.8	11	ESM 16
6	13	ESM 20
9	17	ESM 25
9	23	ESM 32
17	30	ESM 40

**Grommets ESM**

Degree of protection: IP 55  
Grommets are inserted into knockouts.  
No nut is necessary!

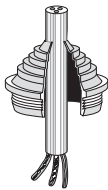

Outside diameter of cables		Cable entry metric
min. mm Ø	max. mm Ø	
3.5	12	STM 16
5	16	STM 20
5	21	STM 25
13	26.5	STM 32
13	34	STM 40

**Stepped grommets STM**

Degree of protection: IP 55  
Stepped grommets are inserted into knock outs.  
No nut is necessary!

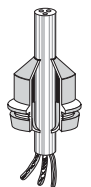

Outside diameter of cables		Cable entry metric
min. mm Ø	max. mm Ø	
5	10	EDK 16
6	13	EDK 20
9	17	EDK 25
8	23	EDK 32
11	30	EDK 40

**Grommets EDK**

Degree of protection: IP 65  
Grommets are inserted into knock outs.  
No nut is necessary!

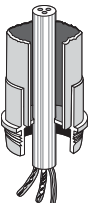

Outside diameter of cables		Cable entry metric
min. mm Ø	max. mm Ø	
Conduit		
M 16		EDR 16
M 20		EDR 20
M 25		EDR 25
M 32		EDR 32
M 40		EDR 40

**Grommets for conduits EDR**

Degree of protection: IP 65  
Grommets for conduits are inserted into knock outs.  
No nut is necessary!

**Hensel cable entries comply with the following standards and regulations:**

- EN 50262  
Metric cable entries for electrical installations
- EN 60423  
Conduits for electrical purposes - Outside diameter of conduits for electrical installations and threads for conduits and fittings
- IEC 60529  
Degrees of protection provided by enclosures (IP-Code)

**Definition of Terms**

Rated values for setting up low-voltage switchgear are given in the standard IEC 61439-1

**Rated voltage ( $U_n$ )**

highest nominal value of the a.c. (r.m.s.) or d.c. voltage, declared by the assembly manufacturer, to which the main circuit(s) of the assembly is (are) designed to be connected.

**Rated operational voltage ( $U_e$ ) (of a circuit of an assembly)**

value of voltage, declared by the assembly manufacturer, which combined with the rated current determines its application.

**Rated insulation voltage ( $U_i$ )**

r.m.s. withstand voltage value, assigned by the assembly manufacturer to the equipment or to a part of it, characterising the specified (long-term) withstand capability of the insulation.

**Rated impulse voltage ( $U_{imp}$ )**

impulse withstand voltage value, declared by the assembly manufacturer, characterising the specified withstand capability of the insulation against transient overvoltages.

**Rated current ( $I_n$ )**

value of current, declared by the assembly manufacturer taking into consideration the ratings of the components, their disposition and application, which can be carried without the temperature-rise of various parts of the assembly exceeding specified limits under specified conditions.

**Prospective short circuit current ( $I_{cp}$ )**

current which flows when the supply conductors to the circuit are short-circuited by a conductor of negligible impedance located as near as practicable to the supply terminals of the assembly.

**Rated peak withstand current ( $I_{pk}$ )**

value of peak short-circuit current, declared by the assembly manufacturer, that can be withstood under specified conditions.

**Rated short-time withstand current ( $I_{cw}$ )**

r.m.s value of short-time current, declared by the assembly manufacturer, that can be carried without damage under specified conditions, defined in terms of a current and time.

**Rated current of the assembly ( $I_{nA}$ )**

The rated current of the assembly is the smaller of:

- the sum of the rated currents of the incoming circuits within the assembly operated in parallel;
- the total current which the main busbar is capable of distributing in the particular assembly arrangement.

This current shall be carried without the temperature rise of the individual parts exceeding the limits specified in the standard.

**Rated current of a circuit ( $I_{nc}$ )**

The rated current of a circuit is stated by the assembly manufacturer, taking into consideration the ratings of the devices within the circuit, their disposition and application. This current shall be carried without the temperature rise of the various parts of the assembly exceeding the limits specified in the standard when the circuit is loaded alone.

**Rated diversity factor (RDF)**

per unit value of the rated current, assigned by the assembly manufacturer, to which outgoing circuits of an assembly can be continuously and simultaneously loaded taking into account the mutual thermal influences.



Request/offer

Order

Date: \_\_\_\_\_

**Contractor:**

**Project:**

Name: \_\_\_\_\_

\_\_\_\_\_

Address: \_\_\_\_\_

\_\_\_\_\_

\_\_\_\_\_

\_\_\_\_\_

Tel.: \_\_\_\_\_

\_\_\_\_\_

E-Mail: \_\_\_\_\_

\_\_\_\_\_

- protection class II
- ready for connection
- with external stainless steel bracket

- lid fasteners for tool operation
- material: thermoplastic
- colour: grey, RAL 7035
- degree of protection: IP 65

Quantity of PV generator junction boxes (pieces): \_\_\_\_\_

**Installation und ambient conditions**

Ambient temperature (°C): \_\_\_\_\_

**Installation**

- **Indoor installation:**  in closed electrical operating room  in factory
- **Outdoor installation:**  protected outdoor  unprotected outdoor

**Available wall surface in mm:** Width: \_\_\_\_\_ Height: \_\_\_\_\_ Depth: \_\_\_\_\_

**Assembly type:**  wall-mounted  floor-standing

**Degree of protection:**  IP 44  IP 54  IP 55  IP 65  IP \_\_\_\_\_

**Connection inverter**

Rated voltage (U<sub>OC ST0</sub>): \_\_\_\_\_ V d.c.

Solar inverter feeding  1  2  3  \_\_\_\_\_

(MPP tracker)

DC generator disconnect  yes  no

switch:

Connection of conductors  Multi Contact MC4  \_\_\_\_\_

going to inverter:  Screw connection and terminals

Cable cross-section (mm<sup>2</sup>): \_\_\_\_\_

Overvoltage protection:  no  yes  Type 1  Type 2  Floating remote indication

Manufacturer:  Dehn  \_\_\_\_\_

Earthing cable type  NYY 1 x 16 mm<sup>2</sup>  \_\_\_\_\_

and diameter:

Cable entry:  Cable glands

**Anschluss Stränge**

Number of strings \_\_\_\_\_

per box:  1  2  3  4  \_\_\_\_\_

Current per string:  15 A  30 A  \_\_\_\_\_

String overload protection:  yes  no

Blocking diodes:  yes  no

Connection of conductors:  Multi Contact MC4  \_\_\_\_\_

Screw connection and terminals

Cable cross-section (mm<sup>2</sup>): \_\_\_\_\_



Request/offer

Order

Date: \_\_\_\_\_

**Contractor:**

**Project:**

Name: \_\_\_\_\_

\_\_\_\_\_

Address: \_\_\_\_\_

\_\_\_\_\_

\_\_\_\_\_

\_\_\_\_\_

Tel.: \_\_\_\_\_

\_\_\_\_\_

E-Mail: \_\_\_\_\_

\_\_\_\_\_

- protection class II
- ready for connection

- material: thermoplastic
- colour: grey, RAL 7035

Quantity of Solar inverter collectors (pieces): \_\_\_\_\_

**Installation und ambient conditions**

Ambient temperature (°C): \_\_\_\_\_

**Installation**

- **Indoor installation:**  in closed electrical operating room  in factory
- **Outdoor installation:**  protected outdoor  unprotected outdoor

**Available wall surface in mm:** Width: \_\_\_\_\_ Height: \_\_\_\_\_ Depth: \_\_\_\_\_

**Assembly type:**  wall-mounted  floor-standing

**Degree of protection:**  IP 44  IP 54  IP 55  IP 65  IP \_\_\_\_\_

**Connection to the public power supply system**

Rated voltage: \_\_\_\_\_ V a.c. \_\_\_\_\_ Hz Rated current: \_\_\_\_\_ A

Conductor designation:  L1, L2, L3  N  PE  PEN

Protection class:  I  II

Incoming device:  HRC fuse switch disconnecter  switch disconnecter  \_\_\_\_\_

**Connection incoming:**

- from top  from below  from left  from right  \_\_\_\_\_
- copper  aluminium
- with cable lug  with terminal
- conductor  single conductor cross-section (mm<sup>2</sup>): \_\_\_\_\_

**Circuits and consumer**

**Solar inverter connection:**

- from top  from below  from left  from right  \_\_\_\_\_
- connected to device  via terminal blocks cross-section (mm<sup>2</sup>): \_\_\_\_\_

Inverter (manufacturer/type): \_\_\_\_\_

Quantity (pieces): \_\_\_\_\_

Output (kVA): \_\_\_\_\_

Current (A): \_\_\_\_\_

Solar inverter connection (1~/3~):  /   /   /   /

RCD (residual current protective):  no  yes  Type A  Type B

Wire protection to solar inverter:  MCB  fuse element  fuse switch disconnecter

Overvoltage protection:  yes  Type 1  Type 2  floating remote indication

**Notes:**

\_\_\_\_\_

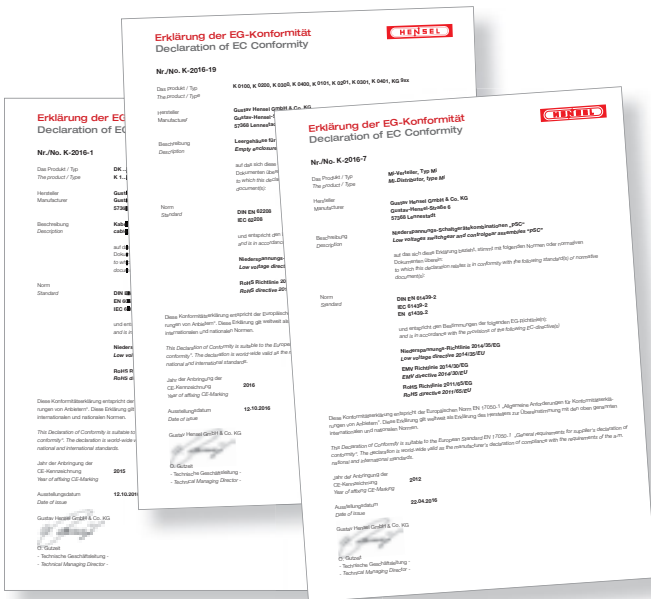

Erklärung der EG-Konformität Declaration of EC Conformity		
<b>Nr./No. K-2016-12</b>		
Das Produkt / Typ The product / Type	FK 0402, FK 0404, FK 0504, FK 0505, FK 1606, FK 1608, FK 1610, FK 1616 FK 8025, FK 9105, FK 9255, FK 9259 FK 7045, 7105, FK 7165 FK 6505	
Hersteller Manufacturer	Gustav Hensel GmbH & Co. KG Gustav-Wiesel-Straße 6 57368 Lennebstadt	
Beschreibung Description	Kabelabzweigkästen mit Funktionserhalt E30-E90 cable junction boxes tested for intrinsic fire resistance E30-E90  auf das sich diese Erklärung bezieht, stimmt mit folgenden Normen oder normativen Dokumenten überein: to which this declaration relates is in conformity with the following standard(s) or normative document(s):	
Name Standard	DIN EN 60670-22 EN 60670-22 IEC 60670-22 DIN 4102-12	
	und entspricht den Bestimmungen der folgenden EG-Richtlinie(n): and is in accordance with the provisions of the following EC-directive(s)	
	<b>Niederspannungs-Richtlinie 2014/35/EG</b> Low voltage directive 2014/35/EG	
	<b>RoHS Richtlinie 2011/65/EG</b> RoHS directive 2011/65/EG	
	Diese Konformitätserklärung entspricht der Europäischen Norm EN 17050-1 „Allgemeine Anforderungen für Konformitätserklärungen von Anbietern“. Diese Erklärung gilt weltweit als Erklärung des Herstellers zur Übereinstimmung mit den oben genannten internationalen und nationalen Normen. This Declaration of Conformity is suitable to the European Standard EN 17050-1 „General requirements for supplier's declaration of conformity“. The declaration is worldwide valid as the manufacturer's declaration of compliance with the requirements of the a.m. national and international standards.	
Jahr der Anbringung der CE-Kennzeichnung Year of affixing CE-Marking	2015	
Ausstellungsdatum Date of issue	22.04.2016	
Gustav Hensel GmbH & Co. KG D 57368 - Technische Geschäftsführung - - Technical Managing Director -	 Gustav Hensel GmbH & Co. KG D 57368 - Technische Geschäftsführung - - Technical Managing Director -	



The current status of EC Declarations of conformity is available on the Internet at [www.hensel-electric.de](http://www.hensel-electric.de) -> Products

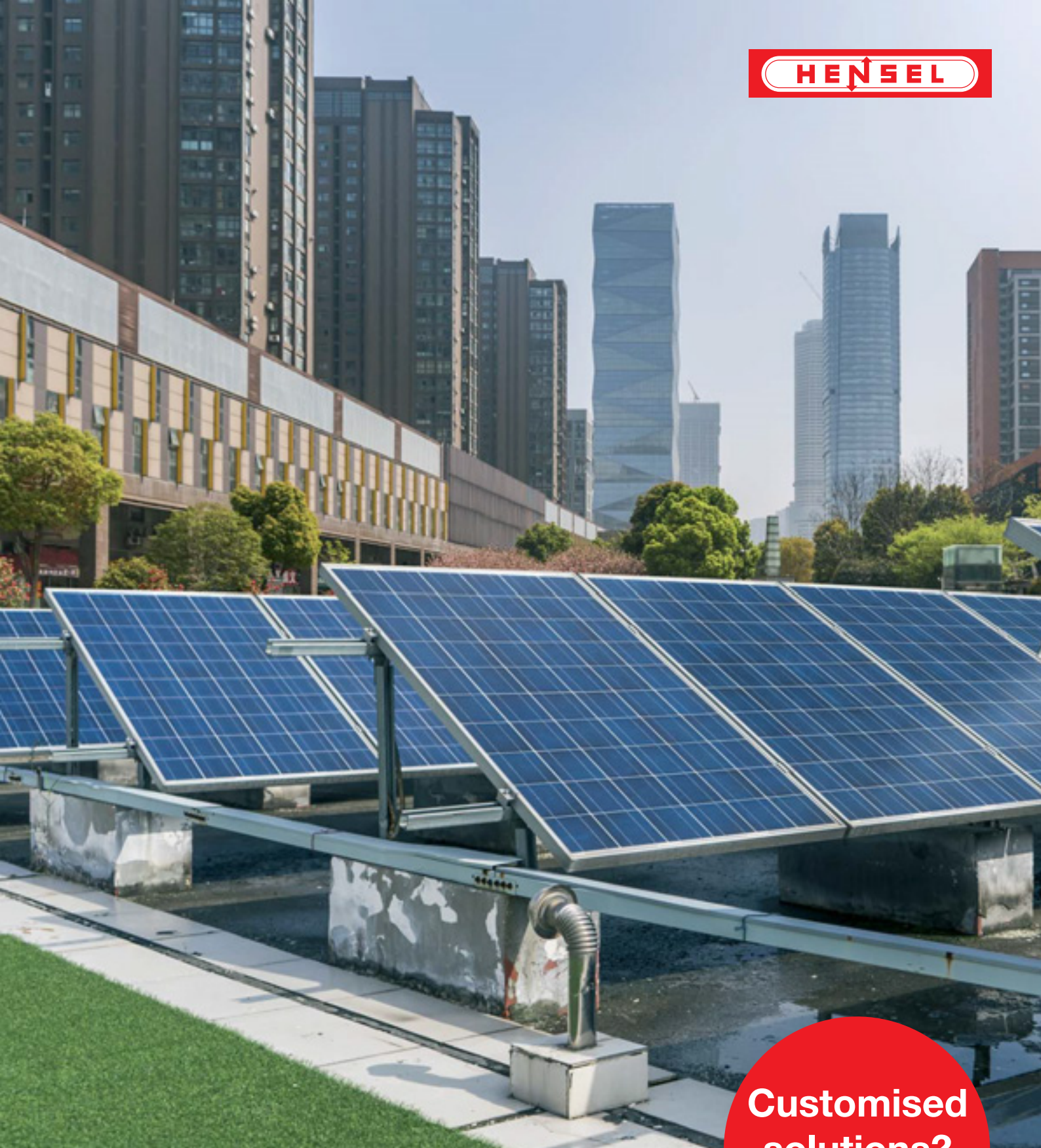

**Customised  
solutions?  
Contact us!**

## **DISCONNECT SWITCH**

Connection of generation systems in accordance with application guide VDE-AR-N 4105:2018-11 and VDE-AR-N 4110:2018-11



**Gustav Hensel GmbH & Co. KG**  
**Elektroinstallations- und Verteilungssysteme**

Altenhudem  
Gustav-Hensel-Straße 6  
D-57368 Lennestadt, Germany  
P.O. Box 1461  
D-57344 Lennestadt, Germany

Phone: +49 (0)2723/609-0  
Fax: +49 (0)2723/60052  
E-Mail: [info@hensel-electric.de](mailto:info@hensel-electric.de)  
[www.hensel-electric.de](http://www.hensel-electric.de)

98 17 1404 05.19/2/11