

## Bus Bars

The positive and negative bus bars are marked with “+” and “-” symbols respectively. The ground terminal is marked with the  $\perp$  symbol and is located beneath the negative bar.

Connect a ground cable to the battery rack. Follow all applicable electrical codes when grounding the rack.

The bus bars have multiple attachment points. The battery cables inside the rack are already attached. For battery loads, attach external positive (+) and negative (-) cables using  $\frac{3}{8}$ ” bolts.

The load cables must be routed inside the enclosure using one of the side openings and must exit using one of the conduit openings on the sides or top.

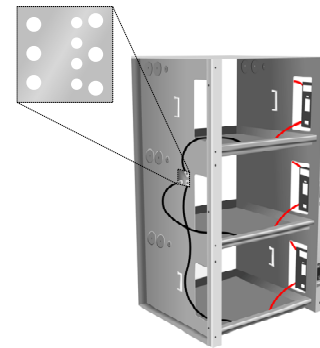

## Protective Shields

Install the protective shields on the left and right sides of the battery rack. Each shield has an edge which is designed to slide into a metal tab on the rack. Once the edge of the shield is secured, attach the other side using M6 screws.

Install the protective shields on the front of each shelf that is occupied by batteries. Make certain to orient the shield correctly. The shield has an opening to allow access to the circuit breaker for each set of batteries. If the shield is oriented incorrectly, it will block access to the circuit breaker.

**NOTE:** The battery rack does not require additional ventilation. Provide adequate ventilation for the room where the rack is installed.

**Installation is complete.**  
**Turn on all circuit breakers and switches.**

## Shunts

This item is optional. Up to three shunts may be installed for the use of a battery monitor such as the OutBack FLEXnet DC. Perform the following steps before beginning the wiring instructions.

**NOTE:** Models IBR-2 and IBR-2-Lithium-Ion can only effectively use two shunts (**A** and **B**), even though three can be mounted.

- Remove the negative bus bar and cables from the left side of the rack as in **C**. Unbolt the individual cables from the bus bar.
- Three pairs of holes are located in the area where the bus bar is mounted. Place a shunt over each set of holes. Each shunt has twin screws (**D**) which can be used for mounting.
- Reinstall the negative bus bar so that it mounts across the inner terminal of each shunt (**E**).
  - Each negative battery cable must not be bolted to the bus bar, but should connect to the outer terminal of each shunt (**F**). The load cable must connect to the negative bus bar.
  - The monitor’s voltage sense wires must connect to the bus bars, not the batteries.

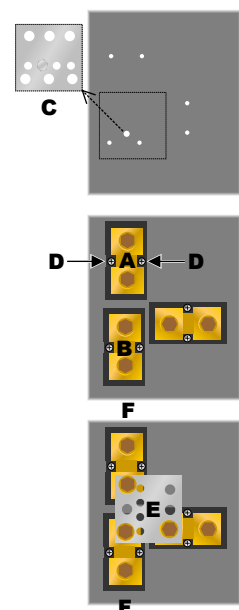
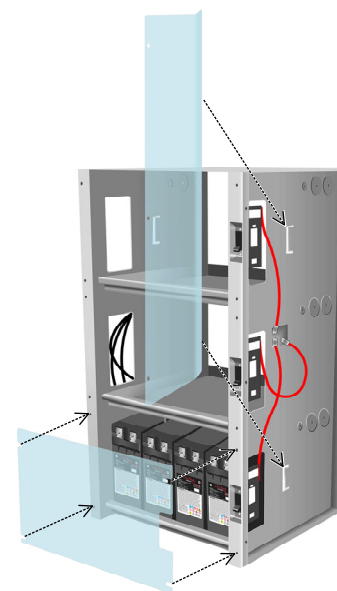

### Date and Revision

November 2018, Revision A

### Contact Information

Mailing Address: Corporate Headquarters  
17825 – 59<sup>th</sup> Avenue NE  
Suite B  
Arlington, WA 98223 USA  
Web Site: [www.outbackpower.com](http://www.outbackpower.com)

# Integrated Battery Rack

## Scope

This document is intended for use by anyone required to install and operate batteries. Be sure to review this manual carefully to identify any potential safety risks before proceeding. The owner must be familiar with all the features of this product before proceeding.

Failure to install or use this product as instructed can result in damage to the product that may not be covered under the limited warranty.

This battery rack accommodates all batteries sold by OutBack Power, as well as other models.

This product has no user-replaceable parts.

## Specifications

- Type 1 enclosure only for indoor use only
- Maximum Current: 140 Adc per shelf
- Maximum Voltage: 68 Vdc / 48 Vdc nominal
- Maximum Continuous Power: 9 kW per shelf
- Maximum Installed kWh: 10.6 kWh per shelf
- Maximum Short-Circuit Current: 10 kAdc
- Ambient Temperature range: -20°C to 40°C  
Installed batteries may reduce the ratings above
- Dimensions (2-shelf models): 33.0 × 27.0 × 24.5 in  
83.8 × 68.6 × 62.2 cm
  - Weight (without batteries): 60 lb / 27 kg
- Dimensions (3-shelf models): 48.6 × 27.0 × 24.5 in  
123.4 × 68.6 × 62.2 cm
  - Weight (without batteries): 89 lb / 40.4 kg
- Maximum capacity for battery weight (per shelf): 560 lb
- Typical weight (per shelf) of approved lithium-ion batteries: 160 lb

See battery literature for specific battery ratings and weights



### ADDITIONAL REQUIREMENTS FOR UL 9540-MARKED SYSTEMS

- The IBR must be installed against a wall or similar surface. The back of the IBR will not be accessible after installation.
- Connected inverters and charge controllers must be certified to UL 1741.
- See Declaration of Conformity for a list of approved batteries.

### The following labels appear on the unit.



#### WARNING

- This unit can cause arcs and sparks.
- Hazardous voltage circuits.



#### WARNING

- To reduce the risk of injury, read all instructions.



### WARNING: Explosion, Electrocution, or Fire Hazard

- A battery can present a risk of electric shock, burns from high short-circuit current, fire, or explosion. Observe proper precautions.
- Ensure the cables are properly sized.
- Ensure clearance requirements are strictly enforced around the batteries.
- Ensure the area around the batteries is well ventilated and clean of debris.
- Never smoke near, the batteries. Never allow a spark or flame near the batteries.
- Always use insulated tools. Avoid dropping tools onto batteries or other electrical parts.
- Never charge a frozen battery.
- If a battery must be removed, always remove the grounded terminal from the battery first. Make sure all devices are de-energized or disconnected to avoid causing a spark.



### IMPORTANT

- Use with copper conductors rated 75°C minimum.
- When installing batteries, leave adequate clearance between batteries.
- If installed in the United States, all wiring methods shall be in accordance with the National Electrical Code (NFPA 70), Current Edition.
- If installed in Canada, all wiring methods shall be in accordance with the Canadian Electrical Code, C22.1, Current Edition.
- Follow the battery manufacturer’s recommendations for installation and maintenance.
- When replacing batteries, use the same number and type of batteries.
- Proper disposal of batteries is required. (See battery literature). Refer to local codes for any battery disposal or IBR disposal requirements.
- Insulate batteries as appropriate against freezing temperatures. A discharged battery will freeze more easily than a charged one.
- Wear complete eye and clothing protection when working with batteries. Avoid touching bare skin or eyes while working near batteries.
- Do not expose to rain or spray.
- Fire suppression equipment must be available in case of fire. The minimum required equipment for this installation is a type ABC fire extinguisher.
- Make certain to follow any other requirements specified in the battery literature.

### For any attached inverters, chargers, or other devices:

- The device ratings cannot exceed the specifications of this battery rack or of the installed batteries.
- If a device is adjustable, the settings must be adjusted before activation to place the device operation within the battery and rack specifications.

## Mounting

### To assemble the integrated battery rack:

1. Install four 1/2" studs into the mounting surface (concrete or a similarly reinforced material). From the front to the back, the stud centers should be spaced 19" (48.3 cm) apart. Spacing from left to right should be 25" (63.5 cm) apart.
2. Lower the battery rack over the four studs and settle the rack in place.  
Alternately, 1/2" bolts can be inserted through the mounting holes into prepared openings.



### IMPORTANT

The battery rack **must** be mounted on a level surface.

3. Secure the studs or bolts with nuts or appropriate hardware. Anchor the rack according to local building codes.
4. Load all batteries into the rack. Load the bottom shelf first to prevent balancing issues. Proceed to the next shelf.

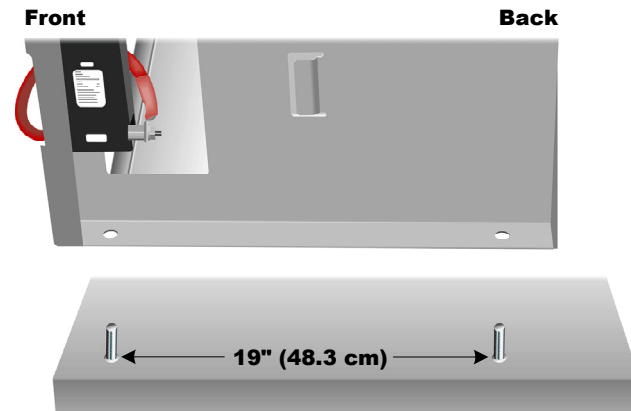

### NOTE

Slots are available under the front edge of each shelf for strapping the batteries down if necessary.

## Wiring

Ensure all circuit breakers or switches are turned off before proceeding. These should be turned on only when wiring is complete.

Batteries should be connected in series as appropriate to meet the system voltage requirements. (Lithium-ion batteries are not usually connected in series.) Batteries installed in series are usually equipped with interconnect bars. In the images to the right, these bars are represented by orange jumpers.



All IBR models are equipped with cables for each shelf (positive on the right, negative on the left). (Lithium-ion IBR models are equipped with cables for individual batteries.) Each positive (red) cable is connected to a 175-amp circuit breaker that protects the cables on that shelf. The cables (and circuit breakers) lead to separate positive and negative bus plates. These are attached to each side of the rack. For clarity, the illustrations to the right depict these plates apart from the rack.

Shunts may be installed if required. Before proceeding, follow the shunt instructions on the back page.

Follow all wiring instructions in the battery manual. Make certain to use the recommended torque values. Do not install terminal hardware in a different order than shown by the battery instructions.

## IBR-2

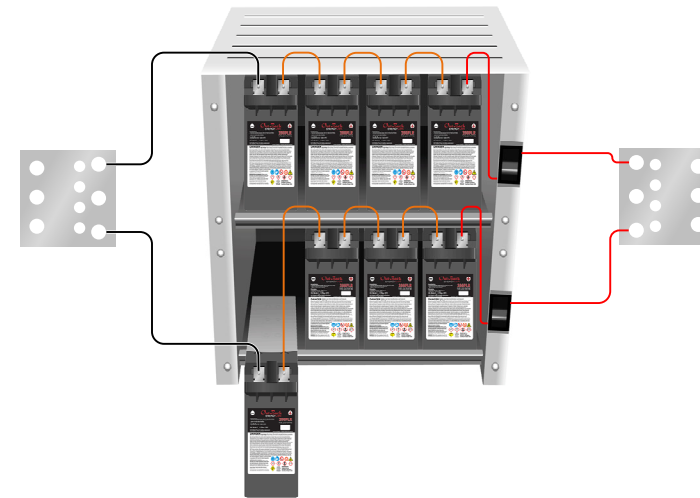

## IBR-2-Lithium-Ion

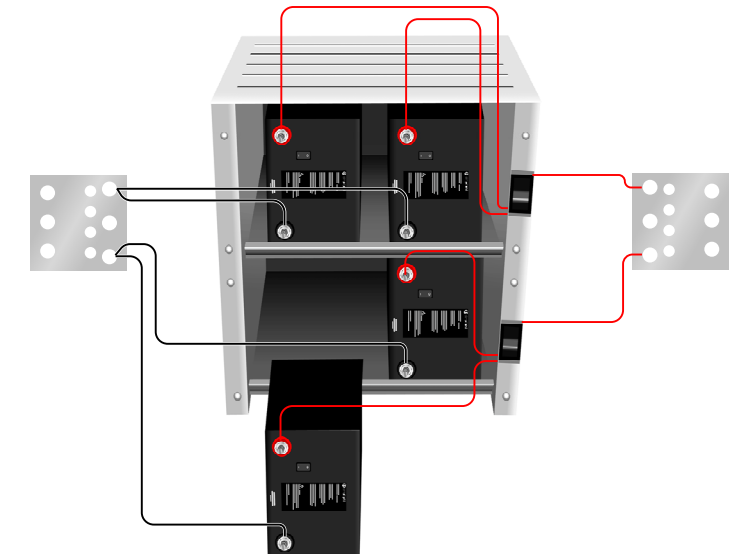

## IBR-3

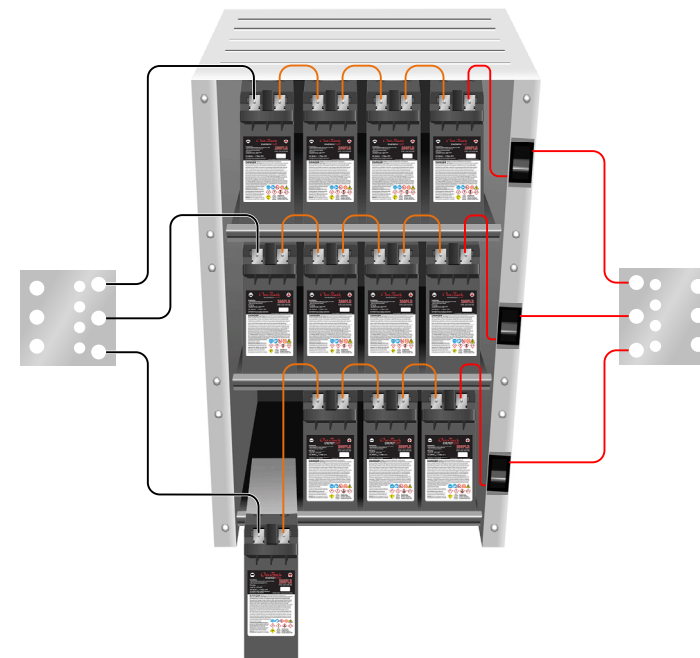

## IBR-3-Lithium-Ion

