

V-BOX-IC Installation instructions

Tools to Prepare



hex key



socket spanner



cross screwdriver

Step 1

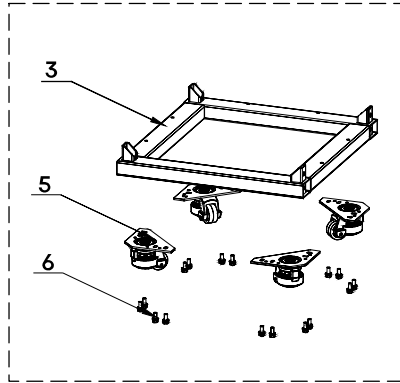

Fasten wheels to bottom rack with M8 screws

Step 2

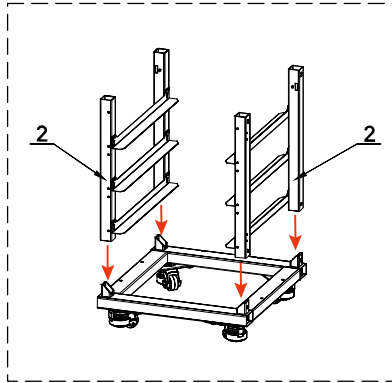

Align side racks to the bottom rack according to picture illustrated.

Step 3

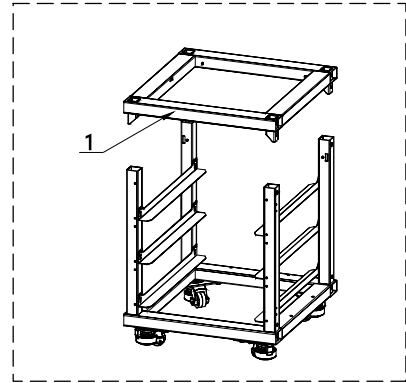

Align the top rack

Step 4

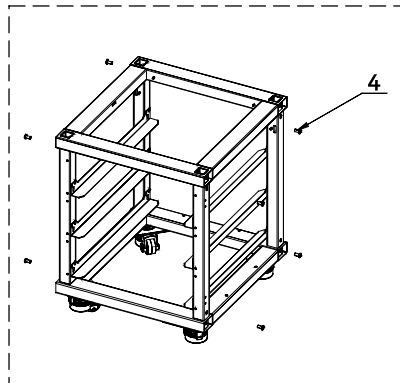

Fasten the racks to each other with M8 screws

Step 5

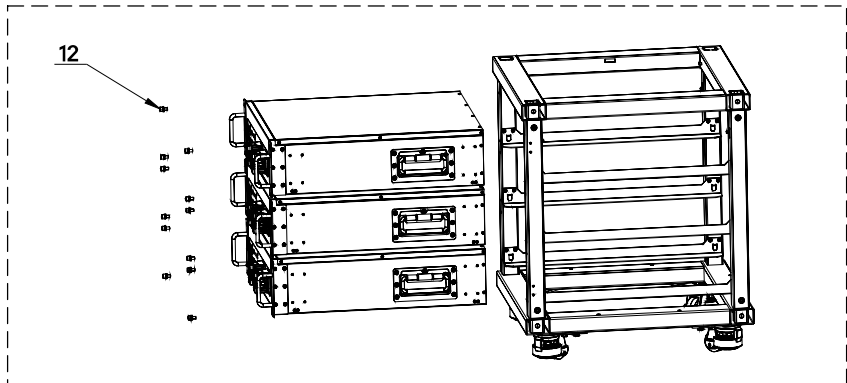

Place and fix batteries to the rack with M6 screws

Step 6

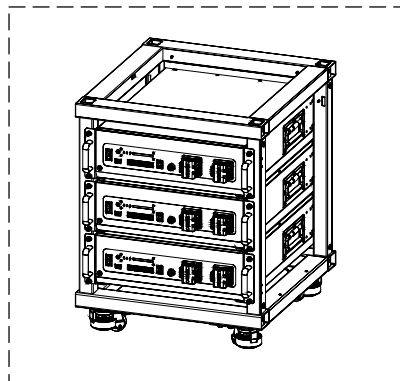

Cabling

Step 7

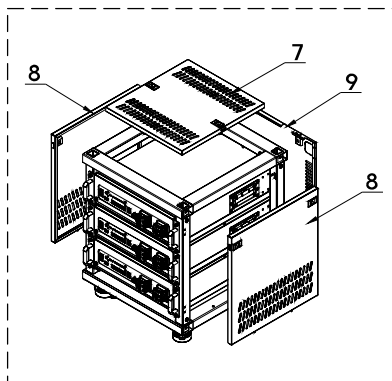

Install plates by insert plate buckles to rack slots



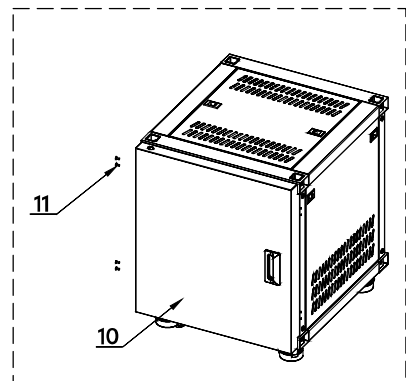





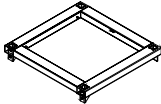
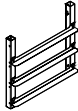
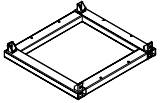

Step 8

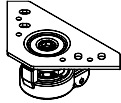

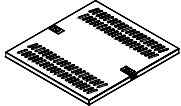
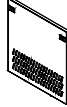
Install the symmetrical structured door to cabinet with KM5 screws

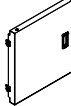
Remarks: Numbers indicated in each picture are corresponding to stuff in packing list.

Packing List

No.	Item	Quantity	Specification	Picture
1	Topframe	1pcs	21.0' ' x22.2' ' x3.2' ' (533x565x80mm)	
2	Side frame (Left=Right)	2pcs	21.5' ' x18.9' ' x3.2' ' (545x480x80mm)	
3	Bottom frame	1pcs	21.0' ' x22.2' ' x3.2' ' (533x565x80mm)	
4	Screw	12pcs	M8 (#5 Inner hexagon nut hole)	
5	Wheel	4pcs	YS-60T	
6	Screw	16pcs	M8(with gasket)	
7	Top cover plate	1pcs	16.2' ' x17.4' ' x0.8' ' (411x443x20mm)	
8	Side cover plate	2pcs	18.3' ' x18.8' ' x0.8' ' (464x478x20mm)	
9	Back cover plate	1pcs	19.0' ' x18.8' ' x0.7' ' (483x478.5x18mm)	
10	Door (Symmetrical Structure)	1pcs	20.6' ' x21.6' ' x2.2' ' (523x548.4x55mm)	
11	Screw	4pcs	KM5X10	
12	Screw	12pcs	ISO 10644G-2014 M6x12 (0.4' ')	
13	Ribbon	2pcs	F07	
14	Warning Labels	5pcs	2.0' ' x3.9' ' (50mmx100mm)	
15	Cabinets Connect Tube	4pcs	1.0' ' x1.0' ' x4.2'' (26x26x106mm)	