

# 1. Flight Mission and Operation

The flight mission consists of the following stages: vertical take-off up to an altitude of 100 m (~330ft), a transition phase to horizontal attitude (pitching down by 90 degrees), cruise of 60 km for 5 kg payload or 100 km for 3 kg payload, 5 minutes loiter, transition phase to vertical attitude (pitching up by 90 degrees), and vertical landing.

## 1.1. Take-Off

For the take-off phase, the drone is designed to accelerate 25kg to 20m/s by an altitude of 100m to be able to generate sufficient airframe lift to assist in the transition phase. The 4 main propellers provide this acceleration, and the two trailing edge propellers are used to initiate the transition phase.

Considering a constant acceleration, the take-off phase should last 8 seconds. For safety reasons, though, we can allow the drone to accelerate in a slower pace for the first 10-20 meters, which would almost double the time needed to reach the required altitude.

## 1.2. Transition Phase

The transition phase starts at an altitude of 100m. At the beginning of the stage, the aircraft lift is purely generated by the 4 main rotors. The aim of the transition phase is to transfer lift generating responsibilities from the rotors to the airframe, so that by the end of the stage the lift is only generated by the airframe.

## 1.3. Cruise

The drone will cruise at 28 m/s for a range of 100km for the 3kg payload, and at 22.5 m/s for a range of 60km for the 5kg payload.

## 1.4. Landing

The choice of a large wing area and low wing loading results in the ability of generating lift at low speeds. This eases the transition from horizontal to vertical flight. The forward position of the main propellers improves the vertical flight dynamics and thus reduces the requirements for the auxiliary propellers.

The drone is able to land on the skids which are located behind the trailing edge of the wing tips.

# 2. Propulsion

The Protean propulsion system generates thrust using propellers driven by battery powered electric motors. There are 4 main rotors located on pylons extending forward of the wing leading edge, and two smaller rotors located on pylons extending rearward of the wing trailing edge. There are two main rotors (which constitute a rotor pair) on each wing, one mounted above the wing and the other mounted below the wing. Each rotor within the pair is positioned with a tilt angle of 10 degrees to the aircraft longitudinal axis such that the two rotors are pitched towards each other. This allows the rotor pair to provide pitch control as well as providing thrust. The trailing edge rotors provide the large pitch rate required in the initial transition phase, and also provide download at the trailing edge during cruise to balance any negative pitching moment not countered by the lower main rotors.

The tilt angle of 10 degrees for additional pitch control in horizontal flight and increased maneuverability in vertical flight

The 4 main rotors were sized by the need to vertically lift a total mass of 25kg (maximum drone mass allowable, including the heaviest required payload). Initial calculations for the power requirements and

efficiency of the propellers lead to a diameter specification of 0.66m.

The 2 smaller rotors were sized to deliver an acceptable pitch rate (17 degrees per second) to transition the aircraft from vertical flight to horizontal flight. The diameter of the small propellers is 0.25m.

Four batteries are used for the main propellers and two for the small ones (one battery per propeller).

## 2.1. Propulsion System Sizing

The selection of the motors and batteries was based on the power requirements for the heavy configuration (5 kg payload) and longest distance covered (100 km).

The disk loading of the main propeller during take-off is about  $24.5 \text{ kg/m}^2$ , while during hover it drops to  $18.5 \text{ kg/m}^2$ . The power requirements change along with the stage in the flight mission. The maximum power per rotor is required during take-off and it is estimated at 1.3 KW.

For the computation of the energy needed from the batteries the flight envelope specifications are used as provided by local motors (1 minute for take-off, 60 minutes cruise flight, 5 minutes loiter, and 1 minute for landing). The total energy requirement per battery is 115 Watt-hours. Using a 9 cell battery (33.3 volt) we get a capacity need of about 3500 mAh. ZIPPY Compact 5800mAh 9S 25C Lipo Pack (166x45x71 mm) was finally selected for the main propeller. Its capacity is 5800mAh which gives us a remaining 40% after the completion of the flight envelope. In fact, given the actual time needed for the drone to complete each stage of the flight, it is estimated that only 35% of the battery capacity is needed, which result in a 2 way flight without the need of charging the batteries. Detailed specifications of the batteries can be found in: [http://www.hobbyking.com/hobbyking/store/\\_21386\\_ZIPPY\\_Compact\\_5800mAh\\_9S\\_25C\\_Lipo\\_Pack.html](http://www.hobbyking.com/hobbyking/store/_21386_ZIPPY_Compact_5800mAh_9S_25C_Lipo_Pack.html)

A motor between U10 and U10 plus Tiger-motor should be used for the main propellers. The external design follows the classical U series high efficiency appearance light in weight (400 grams), and optimized thermal dissipation. Based on the manufacturers the motor is waterproofed and dirt resistant. This motor family along with a propeller of 26x8.5 are able to produce the required thrust for take-off at about 80% of throttle. For the secondary props the brushless motor MT2216 (Tiger-motor) is selected (75 grams). Detailed specifications for all families can be found at: <http://www.rctigermotor.com>

For the secondary motors two Turnigy nano-tech (73x31x35 mm – 155 grams each) with a capacity of 1300 mAh were selected. The capacity is much smaller compared to the main prop batteries, but the requirements for those props are less as they will operate for a limited time during take-off, and for extended controllability of the drone. The total weight of the propulsion system including propellers, motors and batteries is 7 kg.

## 3. Airframe Structure

The V-N diagram of Protean is presented below. A load factor of 3.5 was selected at the beginning as can be seen from the black solid line. The blue dashed-dotted line indicates the load change due to a 10 m/sec gust for 35 m/s speed at 100 m altitude, while the green line presents the gust effect for dive speed at the same altitude. The consideration of the gust is a clear limitation on the design as it gives a load factor of 5.6 at 35 m/sec cruise speed.

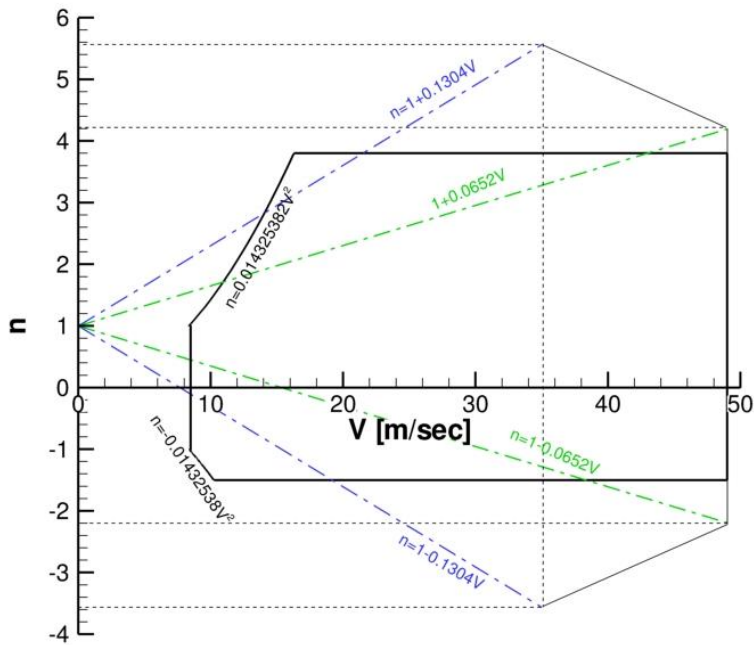

After computing the load distribution on the wing the shear force and bending moment was estimated along the span. Those values were used to size the spars and the ribs of the structure, using the beam theory. As can be seen in the following plots it was decided to use two spars in the inboard section of the wing mainly to secure the connection of the propellers and to avoid twist effects after assembling all parts. The outboard section accommodates one spar. The change in its number made a difference in the loads that ribs in different sections experience, and according to the aluminium properties the number and thickness of the ribs were selected to withstand the aero forces.

Chordwise shear force - rib with 2 spars [N]

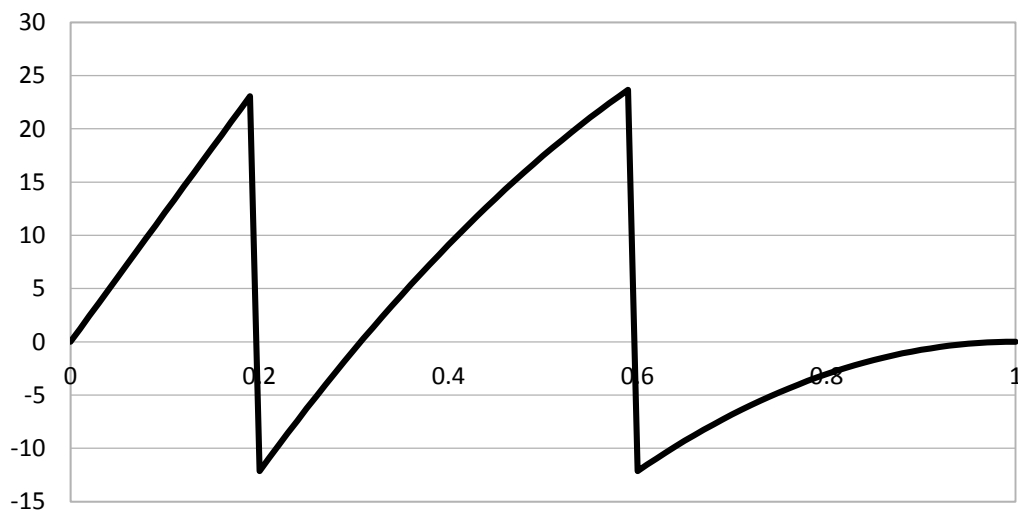

Chordwise shear force - rib with one spar [N]

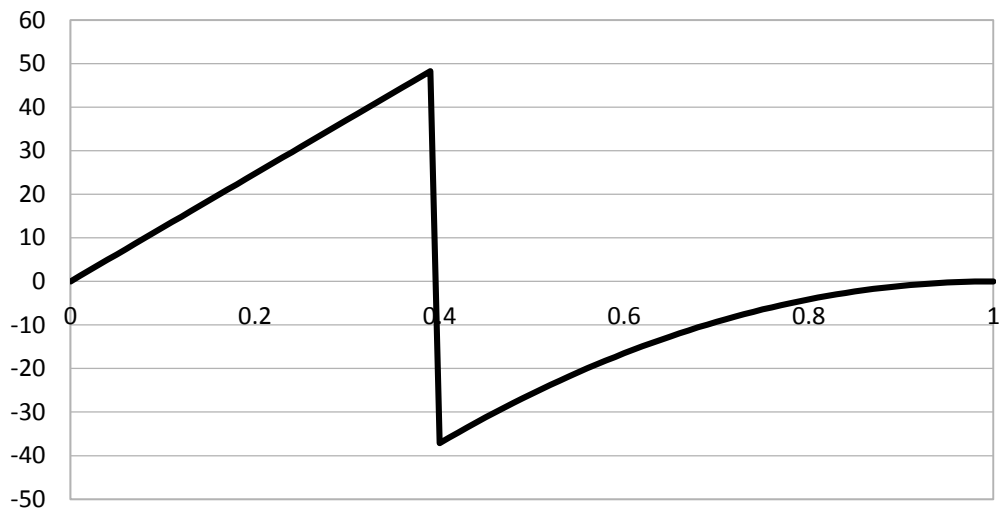

Spanwise shear load [N]

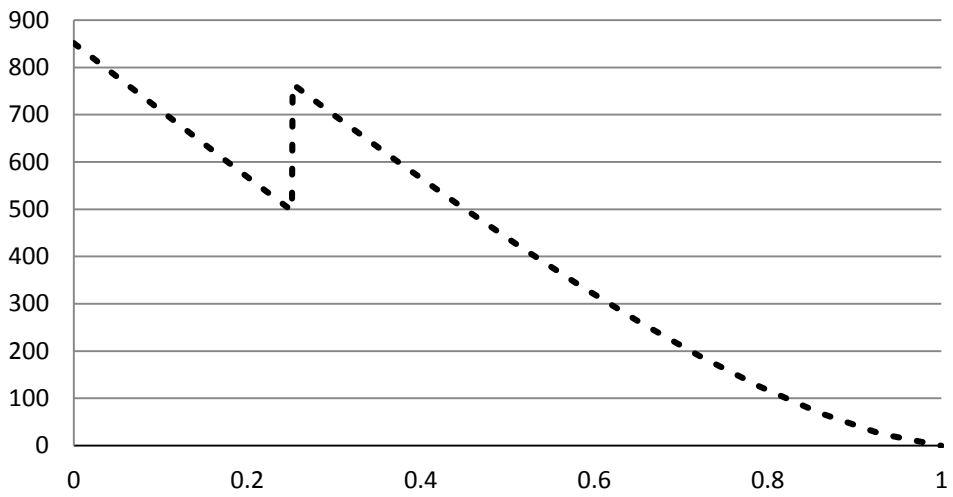

Spanwise bending moment [Nm]

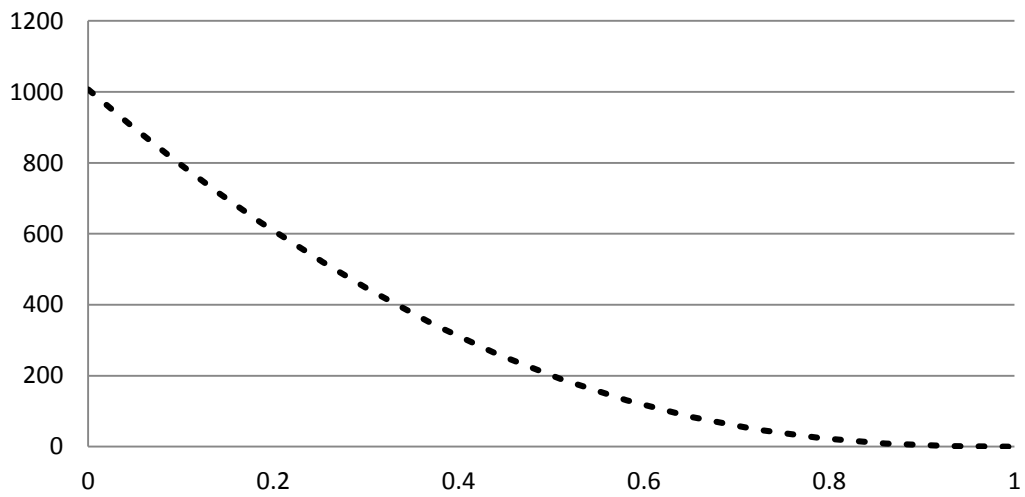

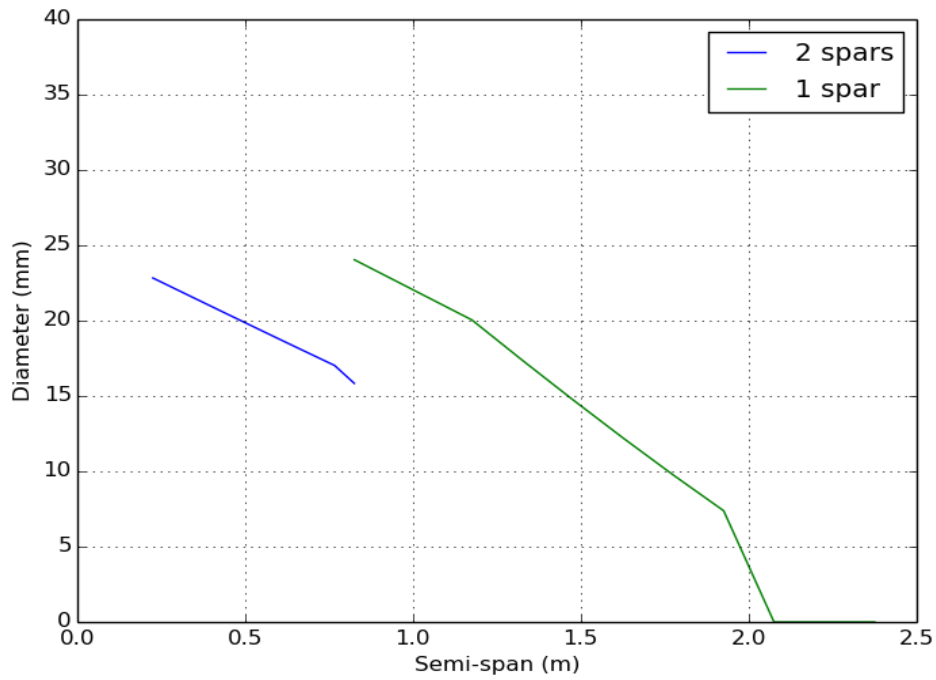

The spars are carbon fibre cylinders with wall thickness of 1.5 mm. The diameters of the spars and the thickness and locations of the ribs are presented in the tables below (note, they show the spars and ribs for the starboard wing).

*Table 1: Spar details for the starboard wing*

Spar	x/c	y start (m)	y end (m)	Length (m)	dia (m)	thickness (m)	Mass (kg)
<b>Forward Spar Outer</b>	0.2	0.225	0.921	1.285	0.028	0.0015	0.254
<b>Forward Spar Inner</b>	0.2	0.846	1.435	0.600	0.027	0.0015	0.112
<b>Centre Spar</b>	0.4	0.733	2.442	1.709	0.027	0.0015	0.320
<b>Rear Spar</b>	0.6	0.225	0.827	1.124	0.028	0.0015	0.223

*Table 2: Rib details for the starboard wing*

Rib ID	y (m)	chord (m)	Thickness (m)	Net Mass (kg)
<b>1</b>	0.225	1.100	0.002	0.674
<b>2</b>	0.528	0.951	0.0015	0.277
<b>3</b>	0.826	0.820	0.002	0.171
<b>4</b>	1.131	0.754	0.001	0.072

<b>5</b>	1.435	0.687	0.001	0.060
<b>6</b>	1.834	0.600	0.001	0.046
<b>7</b>	2.281	0.503	0.001	0.032
<b>8</b>	2.340	0.491	0.0005	0.015

#### 4. Centre of Gravity Calculations

The centre of gravity of the aircraft was calculated by balancing the masses of the structural components, propulsion system, power sources (batteries), systems, and payload. It was estimated to be at 0.46m behind the leading edge of the wing at the root, which corresponded to 17.04% of the aerodynamic mean chord.

Group	Component	Location		Mass (kg)	X Moment about root LE (kgm)	Y Moment about centreline (kgm)	
		x (m)	y (m)				
<b>Airframe</b>	<b>Skin</b>						
	Skin - Stb Centre Wing Inboard	0.550	0.113	0.148	0.082	0.017	
	Skin - Stb Centre Wing Outboard	0.615	0.483	0.309	0.190	0.149	
	Skin - Stb Mid Wing	0.815	1.135	0.332	0.271	0.377	
	Skin - Stb Outer Wing	1.094	1.898	0.259	0.283	0.491	
	Skin - Prt Centre Wing Inboard	0.550	-0.113	0.148	0.082	-0.017	
	Skin - Prt Centre Wing Outboard	0.615	-0.483	0.309	0.190	-0.149	
	Skin - Prt Mid Wing	0.815	-1.135	0.332	0.271	-0.377	
	Skin - Prt Outer Wing	1.094	-1.898	0.259	0.283	-0.491	
	<b>Centre Wingbox</b>						
	Forward Wingbox Spar	0.148	0.000	0.089	0.013	0.000	
	Centre Wingbox Spar	0.532	0.000	0.089	0.047	0.000	
	Rear Winbox Spar	0.900	0.000	0.073			
	Winbox Frame 1	0.110	0.000	0.003	0.000	0.000	
	Winbox Frame 2	0.550	0.000	0.004	0.002	0.000	
	Winbox Frame 3	0.770	0.000	0.003	0.002	0.000	
	Tray	0.716	0.000	0.377	0.270	0.000	
	<b>Spars</b>						
	Forward Spar Outer	0.760	0.573	0.254	0.193	0.146	
	Forward Spar Inner	1.343	1.141	0.112	0.151	0.128	
	Centre Spar	1.442	1.588	0.320	0.462	0.508	
	Rear Spar	1.135	0.526	0.223	0.253	0.117	
	Forward Spar Outer	0.760	-0.573	0.254	0.193	-0.146	
	Forward Spar Inner	1.343	-1.141	0.112	0.151	-0.128	
	Centre Spar	1.442	-1.588	0.320	0.462	-0.508	
	Rear Spar	1.135	-0.526	0.223	0.253	-0.117	
	<b>Ribs</b>						
		1	0.550	0.225	0.674	0.371	0.152
		2	0.626	0.528	0.277	0.173	0.146
		3	0.707	0.826	0.171	0.121	0.141
		4	0.813	1.131	0.072	0.059	0.082

	5	0.919	1.435	0.060	0.055	0.086
	6	1.058	1.834	0.046	0.049	0.084
	7	1.213	2.281	0.032	0.039	0.074
	8	1.266	2.340	0.015	0.019	0.036
	9	0.550	-0.225	0.674	0.371	-0.152
	10	0.626	-0.528	0.277	0.173	-0.146
	11	0.707	-0.826	0.171	0.121	-0.141
	12	0.813	-1.131	0.072	0.059	-0.082
	13	0.919	-1.435	0.060	0.055	-0.086
	14	1.058	-1.834	0.046	0.049	-0.084
	15	1.213	-2.281	0.032	0.039	-0.074
	16	1.266	-2.340	0.015	0.019	-0.036
	<b>Landing Equipment</b>					
	Skid (stb)	1.165	2.374	0.074	0.086	0.176
	Spar (stb)	1.165	2.374	0.027	0.032	0.065
	Skin (stb)	1.165	2.374	0.000	0.000	0.000
	Skid (prt)	1.165	-2.374	0.074	0.086	-0.176
	Spar (prt)	1.165	-2.374	0.027	0.032	-0.065
	Skin (prt)	1.165	-2.374	0.000	0.000	0.000
<b>Propulsion</b>	Stb Main Motor 1 (overwing)	-0.300	0.766	0.400	-0.12	0.306
	Stb Main Prop 1	-0.300	0.766	0.076	-0.023	0.059
	Stb Main Motor 1 Forward Front Pylon	-0.001	0.826	0.080	0.000	0.066
	Stb Main Motor 1 Forward Aft Pylon	0.409	0.826	0.112	0.046	0.093
	Stb Main Motor 1 Support Pylon	0.224	0.677	0.051	0.011	0.035
	Stb Main Motor 2 (underwing)	-0.300	0.766	0.400	-0.120	0.306
	Stb Main Prop 2	-0.300	0.766	0.076	-0.023	0.059
	Stb Main Motor 2 Forward Front Pylon	-0.001	0.826	0.080	0.000	0.066
	Stb Main Motor 2 Forward Aft Pylon	0.409	0.826	0.112	0.046	0.093
	Stb Main Motor 2 Support Pylon	0.224	0.677	0.051	0.011	0.035
	Stb Vertical Motor	1.088	0.766	0.075	0.082	0.057
	Stb Vertical Prop	1.088	0.766	0.006	0.006	0.004



	Stb Vertical Motor Pylon	1.035	0.826	0.023	0.024	0.019
	Prt Main Motor 1 (overwing)	-0.300	-0.766	0.400	-0.120	-0.306
	Prt Main Prop 1	-0.300	-0.766	0.076	-0.023	-0.059
	Prt Main Motor 1 Forward Front Pylon	0.001	-0.826	0.080	0.000	-0.066
	Prt Main Motor 1 Forward Aft Pylon	-0.409	-0.826	0.112	-0.046	-0.093
	Prt Main Motor 1 Support Pylon	-0.224	-0.677	0.051	-0.011	-0.035
	Prt Main Motor 2 (underwing)	-0.300	-0.766	0.400	-0.120	-0.306
	Prt Main Prop 2	-0.300	-0.766	0.076	-0.023	-0.059
	Prt Main Motor 2 Forward Front Pylon	0.001	-0.826	0.080	0.000	-0.066
	Prt Main Motor 2 Forward Aft Pylon	-0.409	-0.826	0.112	-0.046	-0.093
	Prt Main Motor 2 Support Pylon	-0.224	-0.677	0.051	-0.011	-0.035
	Prt Vertical Motor	1.088	-0.766	0.075	0.082	-0.057
	Prt Vertical Prop	1.088	-0.766	0.006	0.006	-0.004
	Prt Vertical Motor Pylon	1.035	-0.826	0.023	0.024	-0.019
<b>Power Source</b>						
	Stb Main Prop 1 Battery	0.325	0.280	1.135	0.369	0.318
	Stb Main Prop 2 Battery	0.346	0.331	1.135	0.393	0.375
	Prt Main Prop 1 Battery	0.325	-0.280	1.135	0.369	-0.318
	Prt Main Prop 2 Battery	0.346	-0.331	1.135	0.393	-0.375
	Stb Vert Prop Battery	0.381	0.368	0.155	0.059	0.057
	Prt Vert Prop Battery	0.381	-0.368	0.155	0.059	-0.057
<b>Systems</b>						
	Flight Control Computer	0.670	0.088	0.580	0.389	0.051
	Inertial Measurement Unit	0.535	0.000	0.058	0.031	0.000
	ADS-B Transponder	0.600	-0.130	0.155	0.093	-0.020
	Antennas, etc...	0.000	0.000	0.322	0.000	0.000
	Flight Termination Parachute	0.820	0.000	1.020	0.836	0.000
	Flight Termination Launcher	0.613	0.000	0.181	0.111	0.000
	Camera System	0.080	0.000	0.483	0.039	0.000
	Communication System	0.731	-0.120	0.575	0.420	-0.069

<b>Payload</b>	Payload (Heavy)	0.340	0.000	5.000	1.700	0.000
Total				23.76	11.02	-0.04
CGPos		17.04	%AMC			
		0.46	m			

## 5. Aerodynamic Performance and Stability

The choice of a flying wing configuration has been made as a compromise between simplicity, manoeuvrability and efficiency. The whole planform has been studied and refined using inviscid vortex lattice methods with a viscous boundary layer coupling.

Flying wings usually pose some problems concerning the pitching moment and the lateral stability. In order to address the first problem, the outer parts of the wing have been designed with a -2 degrees twist. The lateral stability is achieved adding a dihedral of 15 degrees to the outer third of the wing. This has stabilizing properties.

Both the efficiency and the stability of the design have been addressed. The main flight dynamics modes are a phugoid in the longitudinal dimension and a dutch roll in the lateral one. The lateral stability has proven to be quite good, while the longitudinal mode presents low damping but long period, and has been deemed not problematic.

The static margin, which defines the behaviour of the uncontrolled platform has been analysed and a suitable range has been achieved for the considered flight speeds. A too large static margin will define a very slow plane, and then the vertical-to-horizontal flight transition would required additional effort. On the other hand, a close to 0% or negative static margin will result in a platform requiring extended control efforts, or even unstable.

Concerning the aerofoil choice, a quite popular option has been initially considered. Historically, flying wings need a reflexed camber line in order to work against the typical pitching down moment. The aerofoil of choice is the MH60, available free from the internet, which has been tested in wing tunnel and flight. However, the requirements concerning the payload volume required a greater thickness for the central sections. An in-house variant of the MH60 was developed by the team in order to achieve comparable efficiency and pitching-up moment while maintaining a 22% thickness.

The resulting aerodynamic configuration presents very good properties, such as high CL/CD (around 25) and low pitching moment. The following picture summarises the aerodynamic data obtained, including static margin ((XCp-XCG)/MAC), power required for horizontal flight ( $F_x \cdot V_x$ ), pitching moment (M) and efficiency (CL/CD).

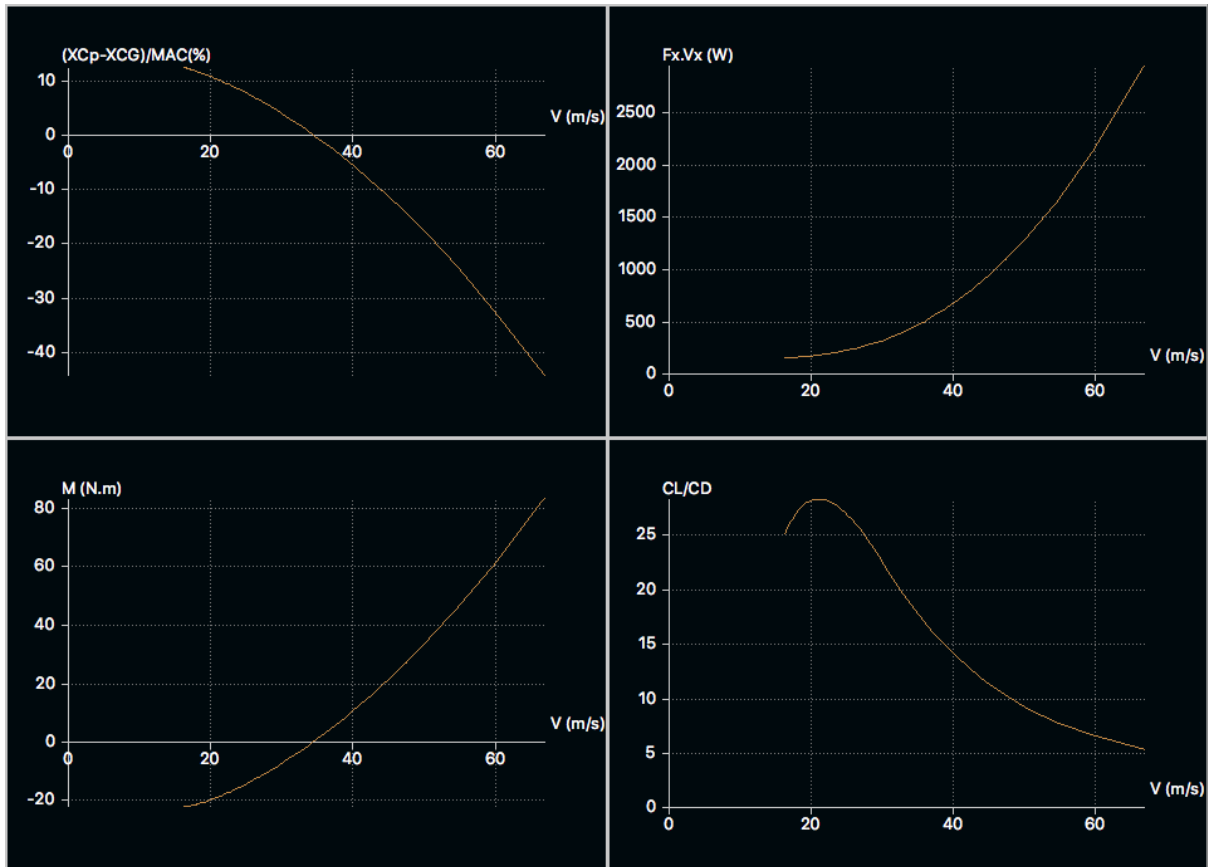

## 6. Other Considerations

### 6.1. Waterproofness

The motors have been verified for their waterproofness by their manufacturers. The fact that the payload bay and the electronics one are separated guarantees the waterproofness and the tamperproofness of the most sensitive parts. The batteries can be accessed from specific panels fitted with rubber seals. The same approach is followed for the assembly panels.

### 6.2. Modularity and Ease of Handling

The wing has been designed so that it can be split in 3 sections. Figure 6-1 thru Figure 6-6 present different views of the drone in assembled or disassembled mode, as well as a detailed view of the payload bay including all the required systems. The middle section (presented in green) is the biggest part of the drone (1.638 m length). The propeller pylons are attached to the middle section in order to make it simple for anyone to assemble the aircraft, and to increase the waterproofness of the configuration. At the connection point of the outer parts of the wing with the middle section there are small access points to facilitate the assembly process. The assembly is done by connecting the rear spar of the outer wing to the outer rib of the middle section, and by sliding the front spar of the outer wing into the front spar of the middle section (to avoid twisting the wing). During operation of the drone the access points are covered with panels with rubber seals. The whole configuration can fit in a 2.122m x 1.452m x 0.941m box. The choice of the skin material has been made so that it can withstand being manipulated by non-trained personnel, featuring a more rigid complexion.

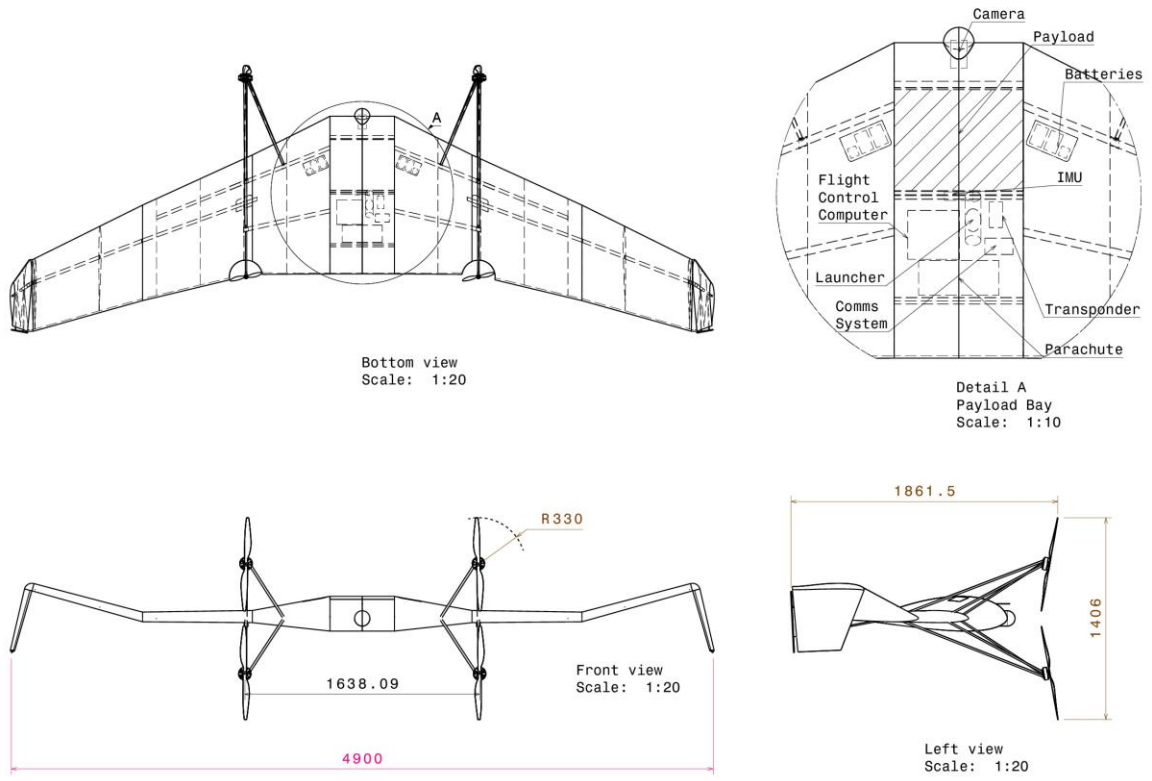

Figure 6-1: Top, front and side view of Protean, and detailed view of payload bay.

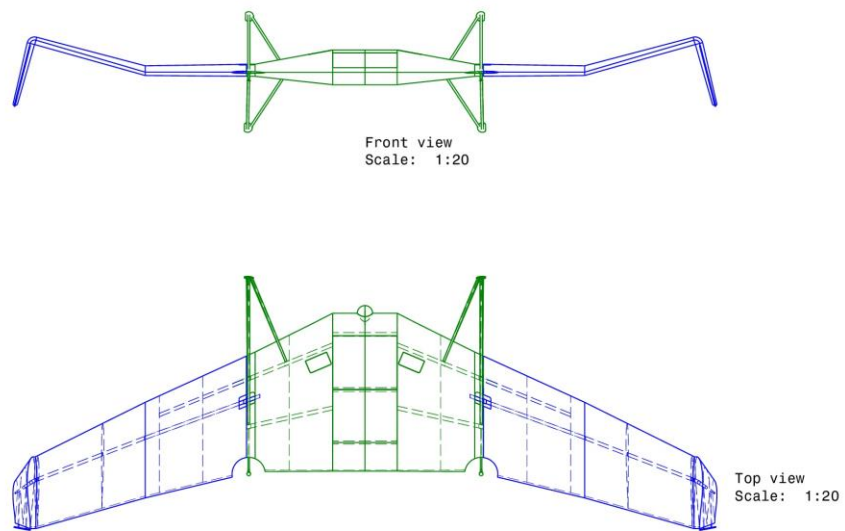
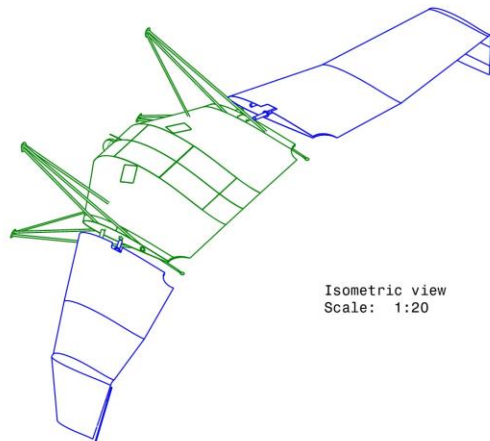
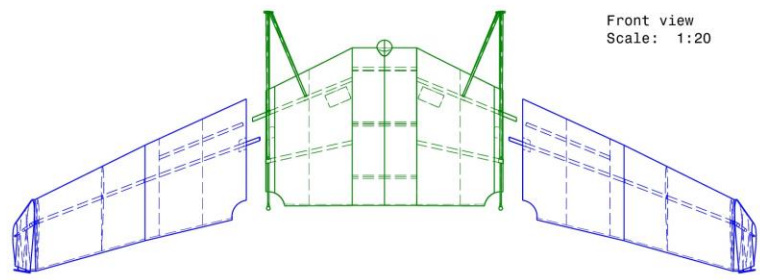
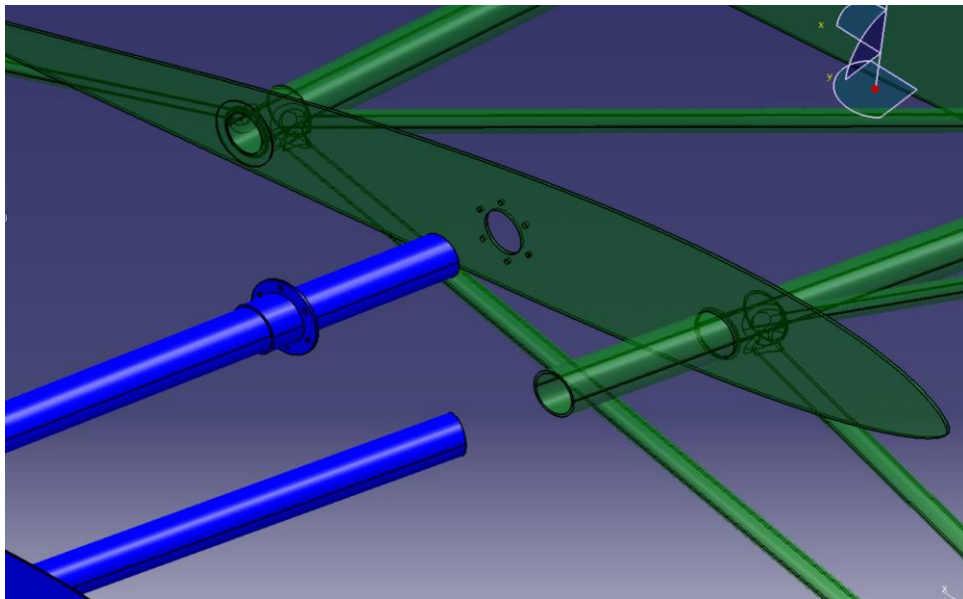

Figure 6-2: Assembled drone.



*Figure 6-3: Disassembled drone.*



*Figure 6-4: Disassembled wing structure.*

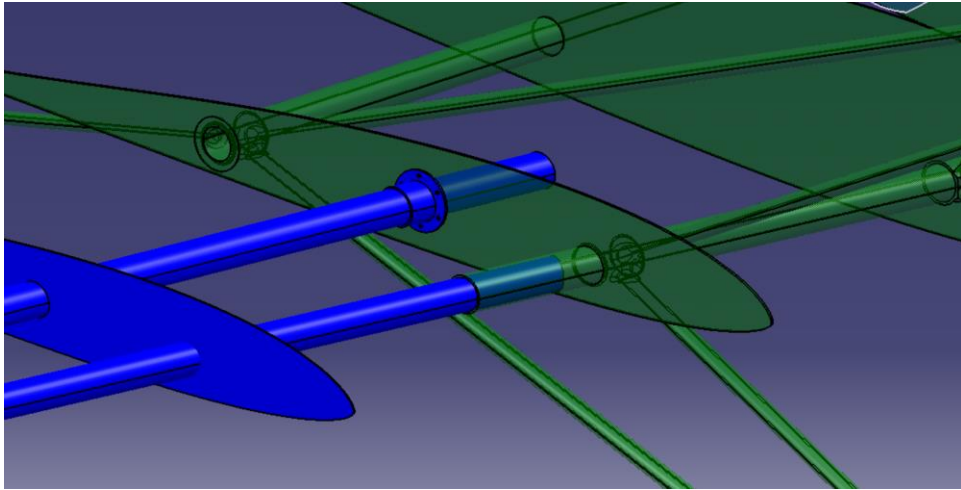

*Figure 6-5: Assembled wing structure.*

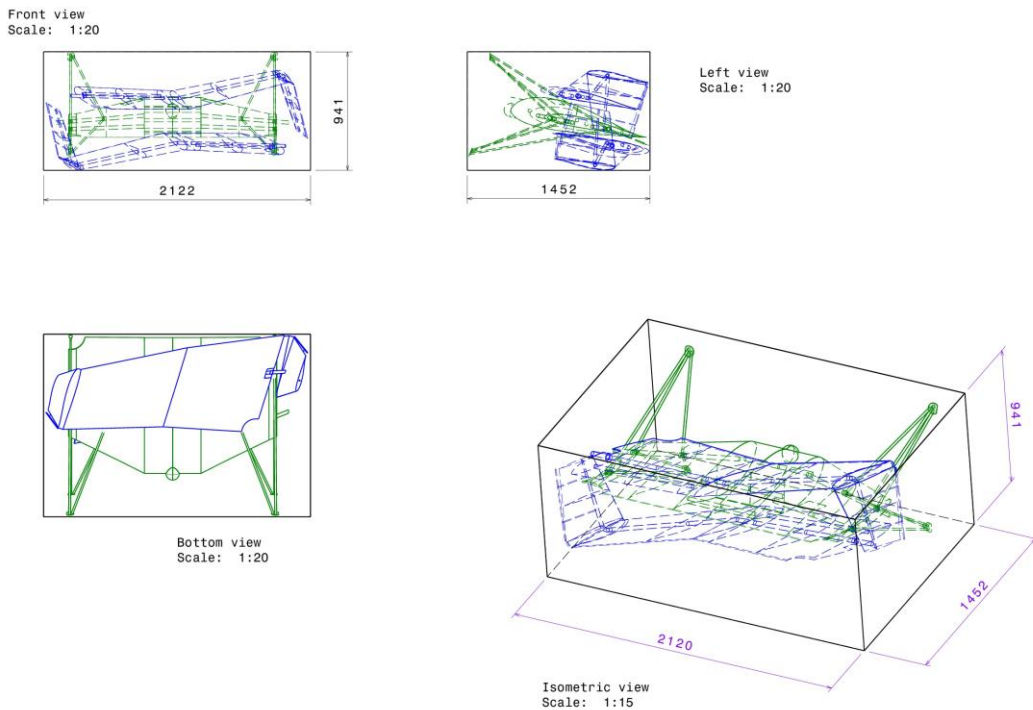

*Figure 6-6: Disassembled drone placed in transportation box.*

### 6.3. Fail Safe Operation

One of the strongest points of our design is the redundancy of the control systems. The tilted propellers allow controlling the motion in an additional dimension, which guarantees the controllability in case of failure of one propeller. In case of a main propeller failure, the aircraft is able to complete the majority of the mission, and just the vertical landing would pose problems. This issue has been considered, and a flight termination system has been fitted for safety purposes.

An important point to consider is the take-off and landing safety. The propellers are quite exposed and can injure a person standing next to it. However, the dimensioning of the rotors has been done such that the time on ground with the motors operating is minimal (less than 2 seconds for reaching 5 m of altitude).