

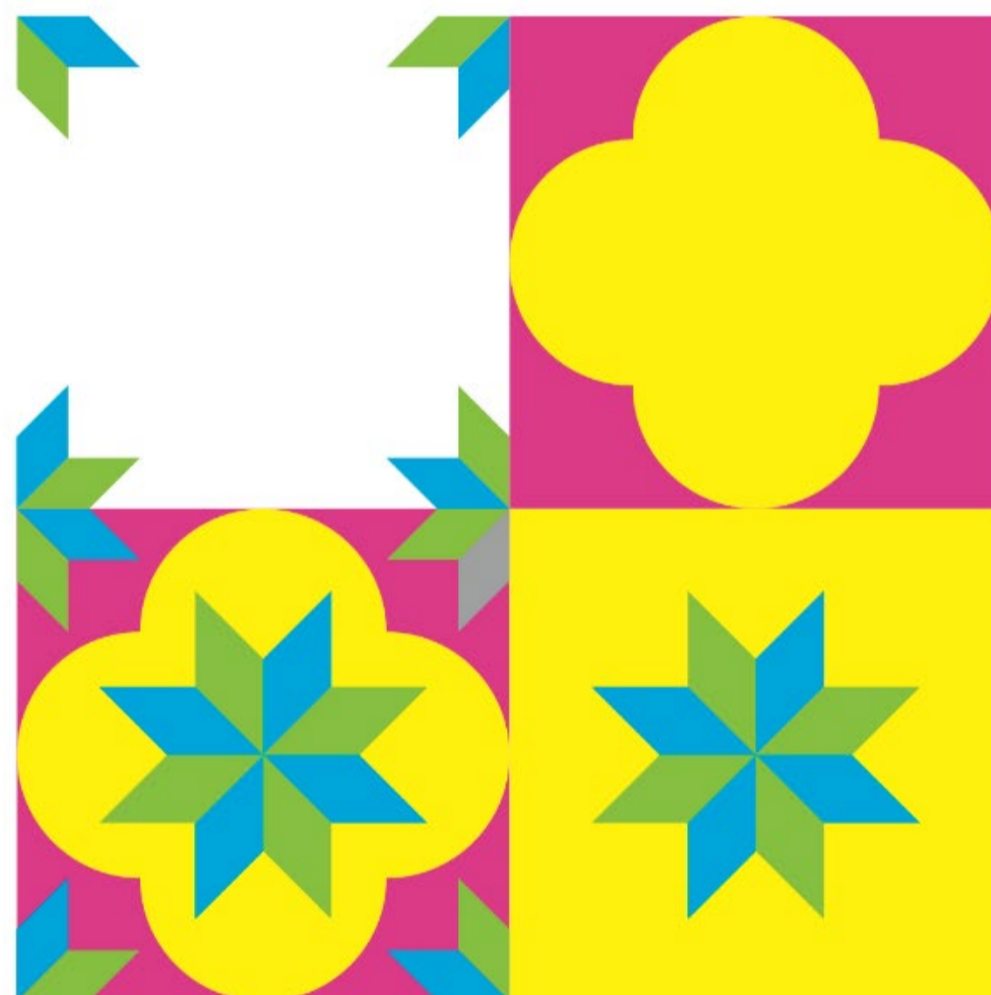

ReInHerit
Redefining the Future of Cultural Heritage, through a
disruptive model of sustainability



ReInHerit
Redefining the Future
of Cultural Heritage

www.reinherit.eu



This project has received funding from the European Union's Horizon 2020 research and innovation programme under grant agreement No 101004545

Project

Project Number	101004545
Project Acronym	ReInHerit
Project Title	Redefining the future of cultural heritage, through a disruptive model of sustainability
Starting Date	01/03/2021
Duration in Months	36
Funding Scheme	Coordination and Support Action
Call (part) Identifier	H2020-SC6-TRANSFORMATIONS-2020
Topic	TRANSFORMATIONS-19-2020 <i>Culture beyond borders – Facilitating innovation and research cooperation between European museums and heritage sites</i>
Website	www.reinherit.eu

Deliverable

Work Package	6
Task	
Deliverable	D6.2-6.7
Dissemination Level	Public
Type of Deliverable	Brochure
Leader	Graz Museum
Due Date	30.09.2022
Submission Date	17.10.2022
Keywords	Exhibition, Open Call, Call for Contribution

Version History

Version	Date	Authors	Notes
V1.0	17.10.2022	Nefeli Bantela, Catalin Betz, Sibylle Dienesch, Helene Gödl, Irimi Khenkin, Martina Schiller, Rainer Stadlbauer, Chiara Zuanni	Review by: Paolo Montemurro (MateraHub), Susanne Ådahl (ARCADA), Dr. Panayiotis Charalambou (CYENS)



ReInHerit
Travelling Exhibition Brochure
→ *Open Call*

ReThinking GENDER IDENTITIES

Intro

Open Call: Hosting an Exhibition

ReThinking GENDER IDENTITIES

Exhibition Design

Visitors Engagement

Whats's Next

Imprint

Intro

Open Call: Hosting an Exhibition

ReThinking GENDER IDENTITIES

Exhibition Design

Visitors Engagement

Whats's Next

Imprint

ReThinking IDENTITIES

Gender Roles, Diversity and Discrimination

A modular Travelling Exhibition

Have you ever considered making your museum's objects part of a European exhibition? Have you always wanted to take on a Travelling Exhibition that allows you to include your own local perspective and references? Are you thinking about innovative and affordable ways to exhibit digital representations of objects in your physical museum space? Are you intent upon offering an exhibition that specifically attracts a young audience?

ReThinking IDENTITIES is a Travelling Exhibition designed for small and medium-sized museums that addresses the above-mentioned questions for the topic of gender roles, diversity and discrimination:

The notion of identities has shifted over time, changing the way gender is experienced in the short term, challenging viewpoints on the different roles held by women in the past and today, sexual diversity and discrimination at multiple layers.

ReThinking IDENTITIES is a Travelling Exhibition that presently covers a small fraction of the topic but has the potential to accommodate a large number of objects and perspectives. It provides a modular structure for the physical space and can host many more objects in the digital collection.

ReThinking IDENTITIES is analogue and digital at the same time. It is easily adaptable and extendable. It is interactive and specially addresses a local audience and young adults.

What is the project about

The Horizon 2020 project ReInHerit focuses on current challenges in the heritage sector across Europe and aims to foster further communication and exchange opportunities between actors of the cultural heritage sector. This includes the networking of Cultural Heritage Sites and museums, the transfer of knowledge, and the exchange and sharing of collections and contents.

Based on the results of the primary and secondary research conducted in the ReInHerit project the three partner museums, Bank of Cyprus Cultural Foundation, Museum of Cycladic Art and Graz Museum have developed three Travelling and three Digital Exhibitions and a Digital Collection in a co-creative process.

Social Issues and the three Thematic Areas

The topic “Social Issues” serves as the basis for the three overarching Thematic Areas. Societal challenges in the changing context of times are of equal concern to societies worldwide. The Thematic Areas “Craftsmanship, Production and Environmental Issues”, “Gender Roles, Diversity and Discrimination” and “Craftsmanship, Production and Environmental Issues” have emerged from this context, taking into account the respective collections.

The subjects and concerns of this exhibition are at its core the different cultural skills and abilities that we cultivate in order to deal with social issues and social topics. If we look at how these skills and abilities are articulated through objects, museum collections can act as a starting point for the display, interpretation, and contextualization of social issues through a pan-European lens.

By having each museum supplement the other’s topic through the open sharing of their collections, the Thematic Areas are no longer separate from each other but in reality, share many commonalities. This collaboration highlights different ways of approaching social issues which fosters multidimensional perspectives and invites other museums to join the discourse.

[Intro](#)[Open Call: Hosting an Exhibition](#)[ReThinking GENDER IDENTITIES](#)[Exhibition Design](#)[Visitors Engagement](#)[Whats's Next](#)[Imprint](#)

The Exhibitions

One Travelling and an online Digital Exhibition will be dedicated to each of the three Thematic Areas. All Thematic Areas will be on display at the three venues in Athens, Nicosia and Graz, with the respective objects, as well as the changing narratives, travelling exclusively digitally. The three exhibitions can subsequently be taken up and expanded by other museums.

Digital Collection

As an integral part of the exhibitions, a digital collection is being created within the three Thematic Areas. In addition to the partner museums, other museums and Cultural Heritage Sites will be invited to contribute their objects to the collection. This growing collection serves as the basis for the exhibitions, and it aims to simplify the exchange of collection objects between museums in the future. It will be hosted on the RelnHerit Digital Hub provided by the University of Graz.

Target Group

The exhibitions intend to address a mainly local audience with a special emphasis on a younger audience. As these visitor groups represent an important audience, specific content and media, such as the integration of Social Media tools, developed with a focus group, are explicitly developed that may make a visit to the exhibitions more attractive.

Intro

Open Call: Hosting an Exhibition

ReThinking GENDER IDENTITIES

Exhibition Design

Visitors Engagement

Whats's Next

Imprint

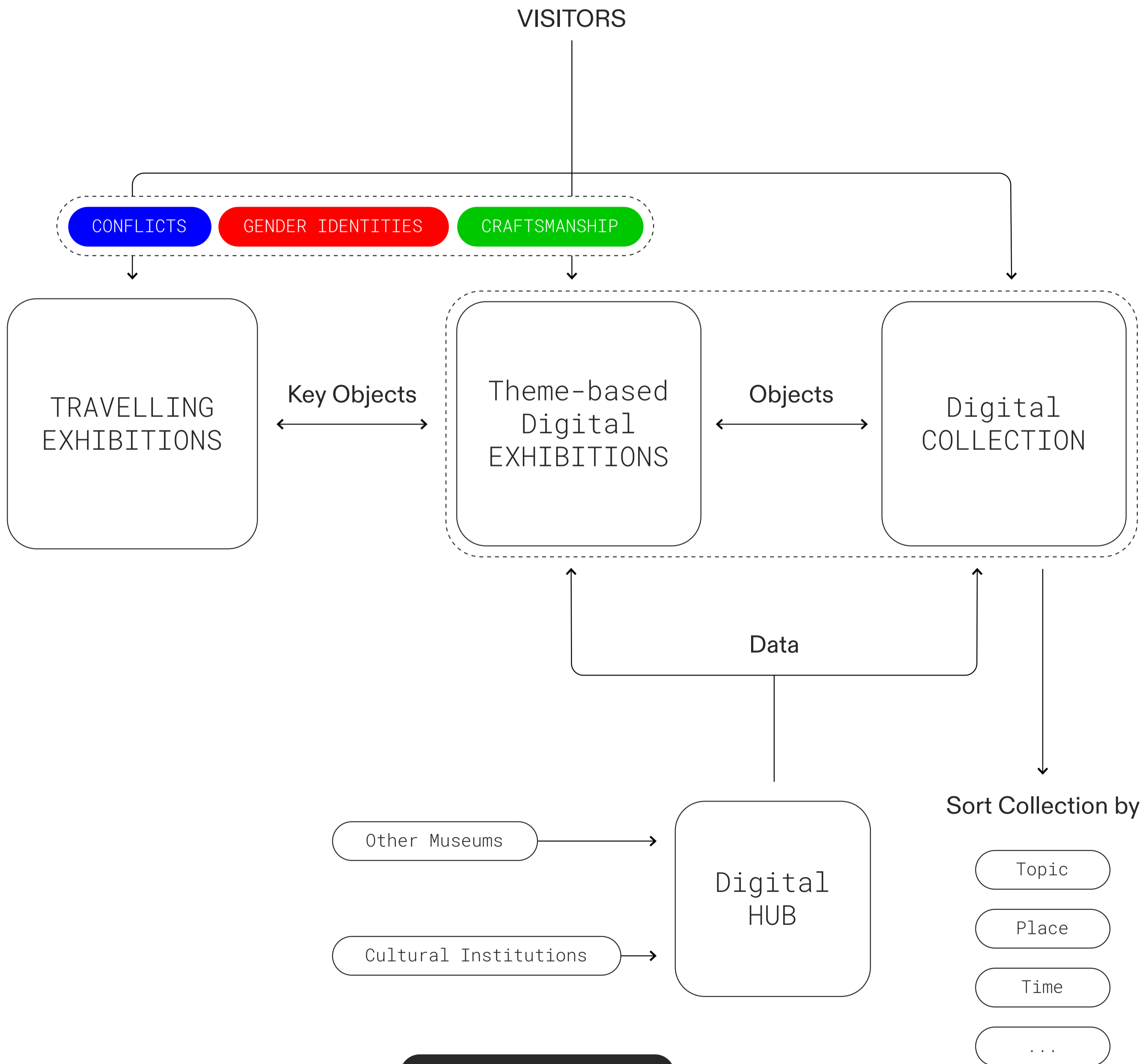

Interested in hosting an exhibition?

Please go to page 9

Intro

Open Call: Hosting an Exhibition

ReThinking GENDER IDENTITIES

Exhibition Design

Visitors Engagement

Whats's Next

Imprint

Call for Hosting an Exhibition

The Travelling Exhibitions aim to be shown in as many different places as possible. To this end, they are designed in such a way that they can also be taken on by smaller and medium-sized museums without major costs and effort. The exhibitions are structurally conceived like a puzzle, which can be expanded with new puzzle elements that can be filled with their own narrative strands and objects. The exhibition will be shared digitally and the easy to implement exhibition architecture can be produced regionally and with locally available resources with the help of concrete instructions.

How to host a Travelling Exhibition

The exhibition concept consists of various puzzle components and aspires to be expanded. Therefore, the already provided content (audios, texts, digital objects) can be taken up and extended with new content and objects from the respective museum/cultural institution. The exhibition grows with each takeover.

In the exceptional case that an interested institution cannot add its own content or would like to show an existing puzzle element within a thematically matching exhibition, it can also be shown without its individual extension.

1

DOWNLOAD INFORMATION

- Thematic Areas
- Exhibition Architecture
- Content Implementation

2

CREATE A NARRATIVE

- Select a topic
- Choose objects
- Find key objects

3

ORGANISING THE CONSTRUCTION

- Check the dimensions of the exhibition space
 - Check what media are needed
- Find local workshops and (reused) material
- Install the structure and the devices

4

CONTENT IMPLEMENTATION

- Download the "implementation instructions"

Intro

Open Call: Hosting an Exhibition

ReThinking GENDER IDENTITIES

Exhibition Design

Visitors Engagement

Whats's Next

Imprint

ReThinking IDENTITIES – Gender, Diversity and Discrimination

In today's world, the notions of gender, sexual diversity and discrimination are more relevant than ever. We constantly face gender issues, instances of discrimination in all spheres of life and changing attitudes towards sexual diversity. However, how novel are such phenomena?

Distinct gender roles have always existed in society from the prehistoric era to our contemporary world. Although it is not easy to make assumptions on the role that women and men held in the Early Cycladic Society as we do today, we can assume that women and men held important but different roles. However, in later years, during the Historic Period, more information about the different roles men and women held is available. Women oversaw the raising of their children, and they only left the house to participate in burial customs and certain religious rituals, carry water for the household needs or visit a relative's grave. Women were also allowed to attend weddings.

Men had an active role in public life while women had an important role within their households. Men could hold office, become warriors, skilled craftsmen, or athletes. The craftsmen of the time were extraordinarily skilled in the techniques they had developed, which results in the remarkable fact that most of these techniques in sculpting and pottery are still alive today with minor changes mostly due to the existence of modern means.

While women were not part of social life, men enjoyed celebrations and symposia with other men. As a result, men formed strong friendships and romantic attachments with each other. During celebrations, it was usual for men to express their admiration for other men publicly. Men also formed strong bonds during the war.

However, in all spheres of activity, discrimination based on social status, social class and wealth, at war and in the society was quite usual. The privileged wealthy men of the society enjoyed certain privileges over other males and women which could be interpreted as a source of social conflict. Violent conflicts in the battlefield were also quite usual at the time due to the upheavals in the Aegean region.

[Intro](#)[Open Call: Hosting an Exhibition](#)[ReThinking GENDER IDENTITIES](#)[Exhibition Design](#)[Visitors Engagement](#)[Whats's Next](#)[Imprint](#)

The three partner museums cover different subjects within one Thematic Area. The diversity of the museums and their collections evoked the emergence and adoption of different perspectives. The objects in all three collections represent parts of social life from different times. They tell stories of the past, but they also give us the opportunity to compare, contrast and reflect on them with the challenges of today.

THE MOTHER – GODDESS: FERTILITY, NATURE, MOTHERHOOD



Cycladic female figurine

2300-2000 BC

Museum of Cycladic Art

Marble figurine of the "canonical" type representing a nude female figure with the arms folded. The elegant marble figurines are the most representative creations of Cycladic Art and were considered as prestige objects of great importance. Figurines of this type range in height from 13 to 76 cm and are almost exclusively female, with characteristic planar surfaces, triangular head, broad angular shoulders and almost straight legs.

They are associated with the feminine aspect of nature, fertility, and religious rituals as suggested by research. Moreover, it can also be an indication of a matriarchal Cycladic society of the time. It seems that gender roles have shifted over time, changing the way gender is experienced in the short term, which can also challenge viewpoints on the different roles held by women in the past and today.

[Intro](#)[Open Call: Hosting an Exhibition](#)[ReThinking GENDER IDENTITIES](#)[Exhibition Design](#)[Visitors Engagement](#)[Whats's Next](#)[Imprint](#)

BETWEEN GENDER ROLES



Self Portrait

Ida Sofia Maly
1928-1930
Graz Museum

The (non-)identification with one gender has always heated up tempers and shed light on general socially accepted role models.

Ida Maly, who lived an unconventional and emancipated life as an artist, depicted herself as a garçonne, a woman of boyish appearance, in her self-portrait. The breaking with stereotyped roles defined by society and the suspension of typically female and male gender identity were characteristic features of her works. Ida Maly was committed to a psychiatric hospital in 1928. In 1941, she was murdered in the frame of the Nazi euthanasia programme.

[Intro](#)[Open Call: Hosting an Exhibition](#)[ReThinking GENDER IDENTITIES](#)[Exhibition Design](#)[Visitors Engagement](#)[Whats's Next](#)[Imprint](#)

QUESTIONING GENDER



Statuette of a temple-boy seated on a roughly rectangular plinth in typical pose

4th century B.C. - Cypro-Classical Period (480-310 B.C.)

Bank of Cyprus Cultural Foundation

Temple-boy statuettes were primarily popular in the Levant region and were presented to male and female divinities as votive offerings representing a wish for male children, connected to the rite of circumcision or depicting male prostitutes in temples. These statuettes offer a glimpse into how gender and sexuality were perceived in the past, and how gender underpinned different aspects of social life such as the socio-sexual dynamics of sacred spaces and the hierarchy of patriarchal societies. By examining how gender roles were depicted in ancient societies, we can use gender as a lens to examine contemporary social structures.

Intro

Open Call: Hosting an Exhibition

ReThinking GENDER IDENTITIES

Exhibition Design

Visitors Engagement

Whats's Next

Imprint

Exhibition Design and Requirements

ReInHerit's Travelling Exhibition architecture adapts to the specific conditions of each venue. It is modular, flexible in use and expandable. The design of the modular components is related to the physical dimensions of digital key objects as core entities. Each of the key objects defines a spatial footprint in the exhibition spaces independently of its actual physical presence. Transport boxes materialise the dimensions of the objects within the network of the exhibition and redefine the absence of objects as different form of presence. Various properties of the key objects can be exhibited via digital media like projection mapping or holography.

Measure the dimensions of a possible exhibition space:

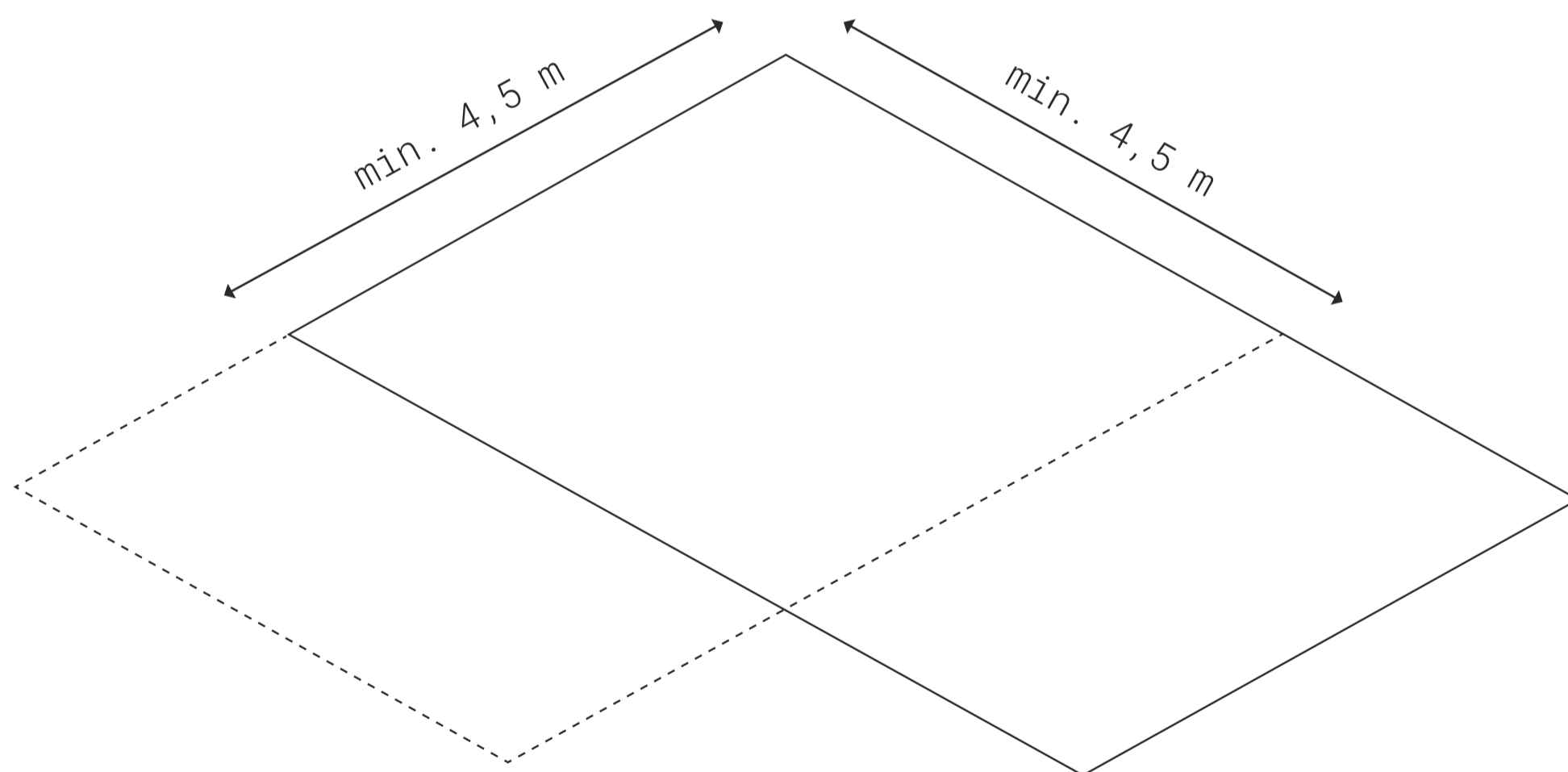

Area must be at least 45 m² &
no side may be less than 4,5 m

Choose display elements which relate to key elements:

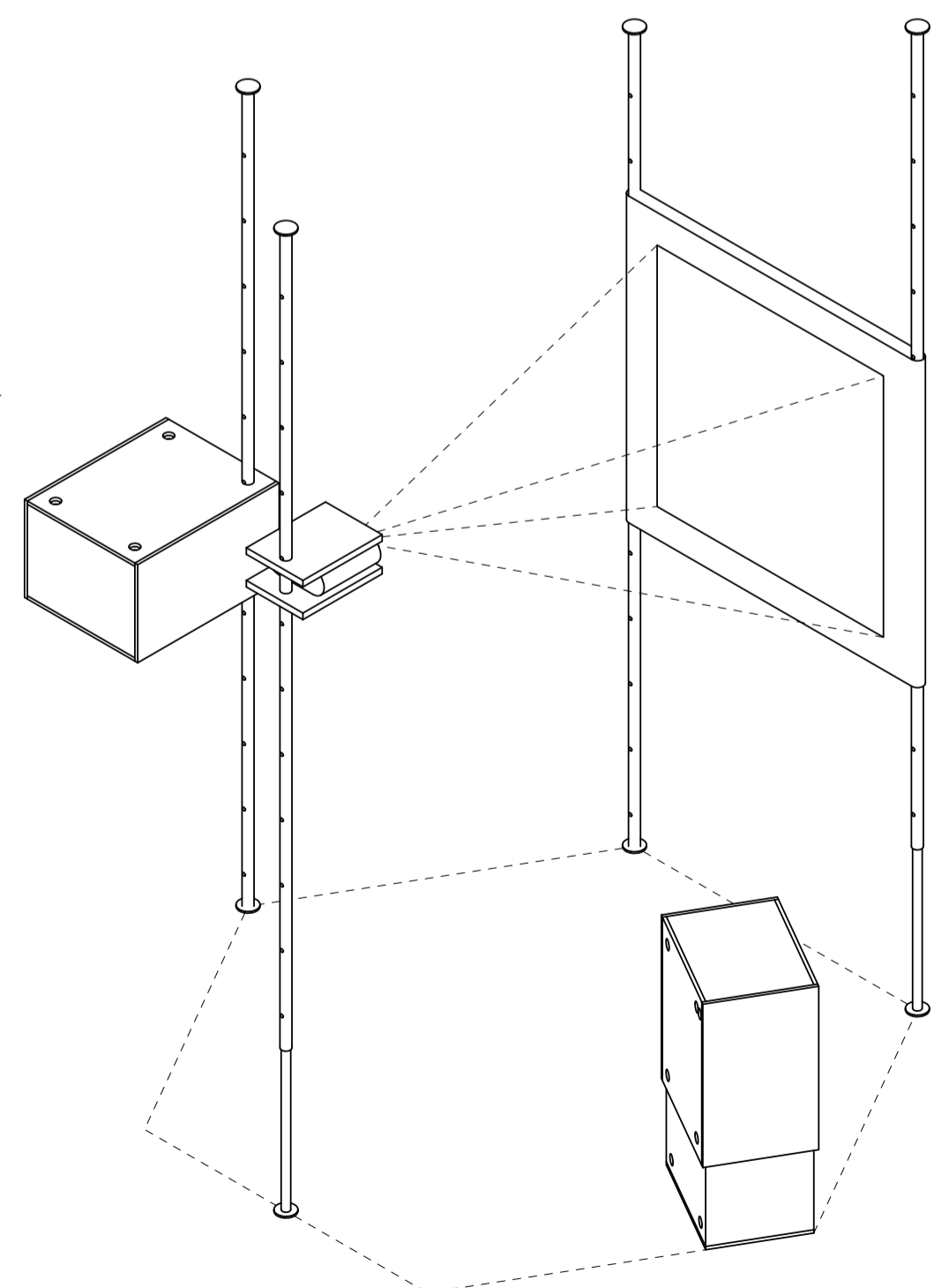

Intro

Open Call: Hosting an Exhibition

ReThinking GENDER IDENTITIES

Exhibition Design

Visitors Engagement

Whats's Next

Imprint

Telescopic rods serve as anchor points for different screens within the display system. Depending on the point of view and interactive use of different media, each visitor creates his/her personal exhibition space. The display system can be adopted by a growing number of museums in the future. Instructions are provided so that the architecture can be produced by local carpenters and with the materials commonly used in the region.

Define the relation of key objects through
defining a spatial network:

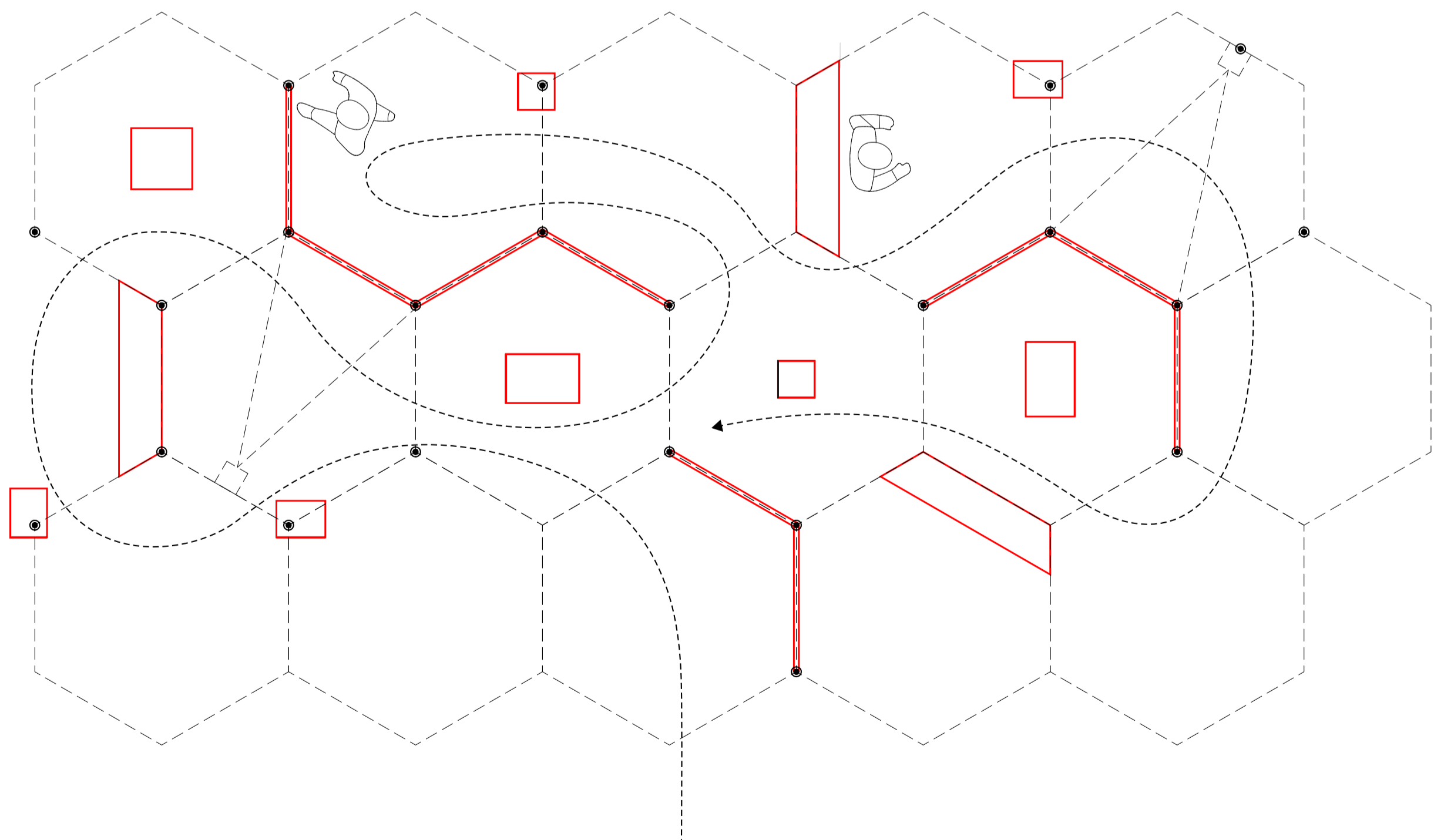

Digital Exhibition Formats

The basis for the digital representations is the use of projection technology. From this technological basis, the participating museums are free to choose a modality that works for each object, their respective exhibition spaces and their resources. The possibilities range from simple projections on projection fabric or mesh to using more elaborate applications like projection mapping and interactive projections.

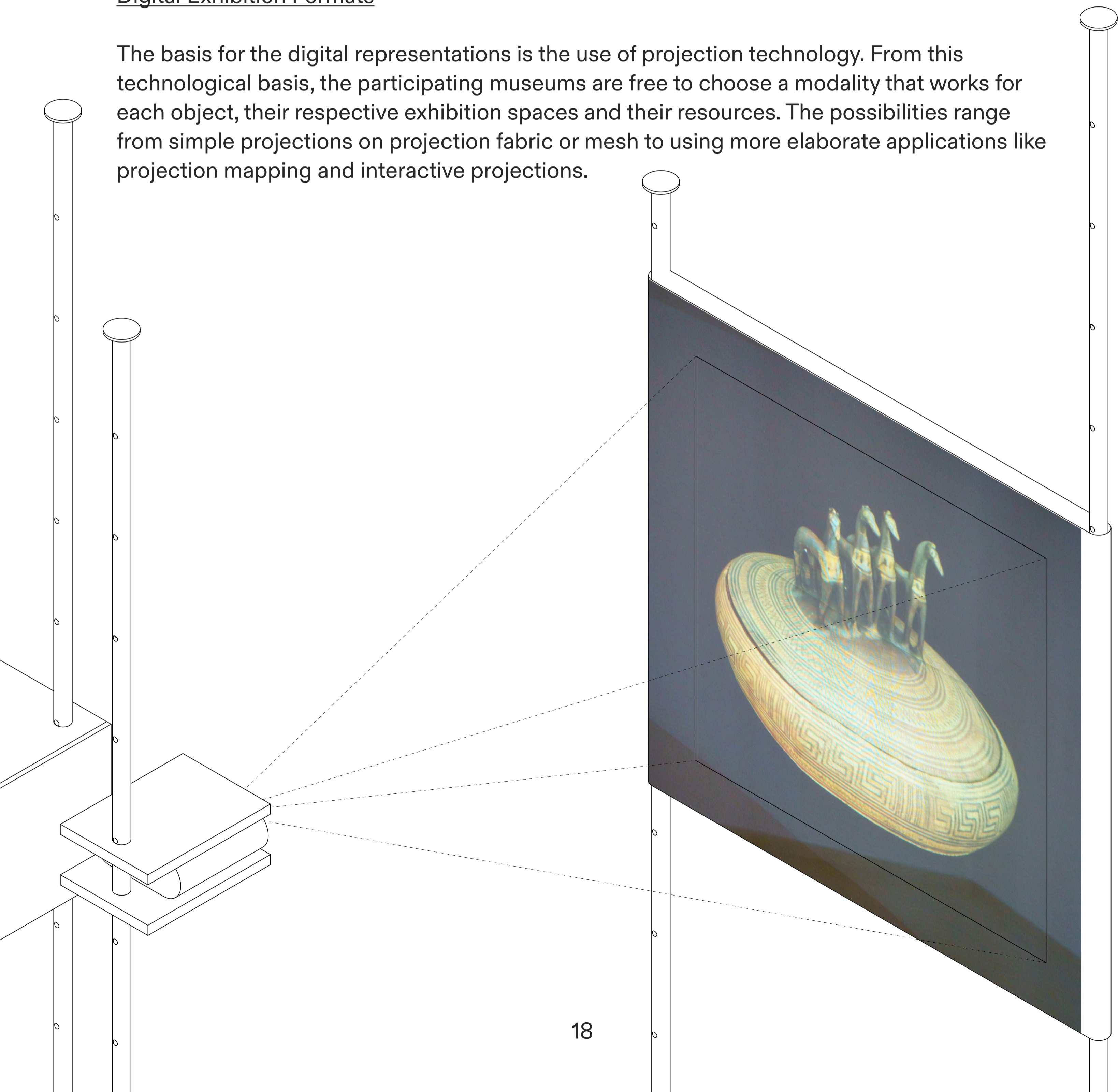

Intro

Open Call: Hosting an Exhibition

ReThinking GENDER IDENTITIES

Exhibition Design

Visitors Engagement

Whats's Next

Imprint

[Intro](#)[Open Call: Hosting an Exhibition](#)[ReThinking GENDER IDENTITIES](#)[Exhibition Design](#)[Visitors Engagement](#)[Whats's Next](#)[Imprint](#)

→ Workshops

Common Event

From 27 to 31 March 2023, a joint week of workshops, impulse lectures, discussion sessions and other opportunities for interaction will take place. Interested people and visitors from all over the world can participate in the programme online or on site in Athens, Graz or Nicosia, exchange ideas and experience how the three locations and the three exhibition subjects grow together.

Additional Programme

Across the duration of the exhibitions, the museums will offer different workshops that correspond to the Thematic Areas displayed at the time. Each museum develops workshop formats based on the topics. The museums can then pass on their formats and suggestions among each other and the participating museums and Cultural Heritage Sites. The programme addresses a heterogeneous target audience with a focus on young and local participants.

→ Engagement in the Travelling Exhibition

Thematic Frames

Each of the three exhibitions includes interactive stations, which provide a thematic frame. The visitors are involved in the exhibition before entering (Intro), at various points in the exhibition (Stations) and after leaving the exhibition (Outro). The involvement is geared towards the respective exhibition topic and is therefore integrated into the Travelling Exhibition in a digital, analogue and partly hybrid format. The digital stations will collect the input from visitors anonymously and the collected data will be visible in the form of a general overview, offering a comparison of visitors input from other places around the world.

[Intro](#)[Open Call: Hosting an Exhibition](#)[ReThinking GENDER IDENTITIES](#)[Exhibition Design](#)[Visitors Engagement](#)[Whats's Next](#)[Imprint](#)

ReThinking GENDER IDENTITIES

The opener of the Thematic Area are personal visitor questions regarding the topics "Gender Roles, Diversity and Discrimination". These questions are connecting early Cycladic role allocations with social gender and discrimination issues of today and give the visitors – already by entering the room – a notion of the timeliness of the topic and to engage them to create their own thoughts. Although we assume that the subject of gender identity existed already in the Cycladic period, the term vary from society to society and from culture to culture and it is still a striking topic today. The Outro contains interactive elements, such as painting activities, weaving the loom and interactive boards.

Taking Action

In the Travelling Exhibitions, visitors can interact with some of the digital key objects. This is realised through gesture-controlled, playful applications of the 3D objects or through the Smart Lens developed by the University of Florence as part of the ReInHerit Toolkit. The Smart Lens may also be provided to the hosting institutions to integrate their objects.

Social Media Engagement

As young visitors are expected to be the main audience, each museum develops a strategy for the respective Social Media channels. One part of the strategy will be for the outreach before and during the exhibition, therefore hashtags for every Thematic Area will be created and a young audience will be engaged, by specific tasks, to share or develop content on their own. The other part contains content and information of the exhibition and invites visitors and users of the exhibition to create new content out of it e.g. digital 3D models of the exhibitions will be implemented to AI Instagram filters and can be projected in any other place – photos can be taken and shared.

Intro

Open Call: Hosting an Exhibition

ReThinking GENDER IDENTITIES

Exhibition Design

Visitors Engagement

Whats's Next

Imprint

Intro

Open Call: Hosting an Exhibition

ReThinking GENDER IDENTITIES

Exhibition Design

Visitors Engagement

Whats's Next

Imprint

Travelling Exhibitions 2023

Museum of Cycladic Art

Athens

Week 12 – 15

Week 18 – 21

Week 24 – 26

GENDER IDENT.

CRAFTSMANSHIP

CONFLICTS

Graz Museum

Graz

Week 6 – Week 19

Week 24 – Week 36

Week 41 – Week 51

CONFLICTS

GENDER IDENTITIES

CRAFTSMANSHIP

Bank of Cyprus Cultural Foundation

Nicosia

Week 9 – Week 21

Week 25 – Week 36

Week 40 – Week 51

CRAFTSMANSHIP

CONFLICTS

GENDER IDENTITIES

Intro

Open Call: Hosting an Exhibition

ReThinking GENDER IDENTITIES

Exhibition Design

Visitors Engagement

Whats's Next

Imprint

When may I download the files?

15 January 2023

www.reinherit-hub.eu/resources



What will be provided?

- An info sheet about how to host an exhibition
- Instructions about the exhibition architecture
- A manual about the estimated costs of the exhibition
- The digital content of the existing Thematic Areas (digital objects, audios, texts...)
- A webinar about producing 3D objects

How will the exhibition be licensed?

This exhibition is licensed under a Creative Commons Attribution Share Alike licence. Further details on the licence as well as terms and conditions that apply for redistribution can be found soon on the ReInHerit Digital Hub.

Intro

Open Call: Hosting an Exhibition

ReThinking GENDER IDENTITIES

Exhibition Design

Visitors Engagement

Whats's Next

Imprint

Intro

Open Call: Hosting an Exhibition

ReThinking GENDER IDENTITIES

Exhibition Design

Visitors Engagement

Whats's Next

Imprint

Imprint



This project has received funding from the European Union's Horizon 2020 research and innovation programme under grant agreement No 101004545.

Contact

Museum of Cycladic Art

www.cycladic.gr/en

Nefeli Bantela

nbantela@cycladic.gr



Project Partners



www.grazmuseum.at/en/



Bank of Cyprus
Cultural Foundation

www.boccf.org

Exhibition Design

studio-itzo

www.studio-itzo.com

Licence

This brochure is licensed under a Creative Commons Attribution NonCommercial NoDerivatives 4.0 International Licence. It allows reusers to copy and distribute the material in any medium or format in unadapted form only, for non commercial purposes only, and only so long as attribution is given to the creator.

