

SPLIT CORE CURRENT TRANSFORMERS

Features

- > Split core for easy installation; ideal for retrofit
- > No exposed metal parts when assembled
- > 0.333 VAC output at rated current
- > Safer to install and use than CTs with a current secondary
- > UL Listed, CE recognized, and RoHS compliant

DESCRIPTION

These split-core current transformers (CTs) from Continental Control Systems offer an easy, safe, and inexpensive method for monitoring electrical energy usage.

Ideal for retrofit applications, the split core makes it possible to attach the CT without disturbing existing wiring. Just open the CT, slip it over the wire, and snap the CT closed. Once assembled, the CTs have no exposed metal parts.

The 0.333 VAC output of these CTs is low, making them much more safe to install and use than CTs with current secondaries. These CTs are also less expensive.

ACT series CTs are accurate to $\pm 0.75\%$ from 1% to 120% of rated primary current. They also have exceptionally low phase angle error, which is essential for accurate power and energy measurements. ACT series CTs comply with the linearity and accuracy requirements of IEEE/ANSI C57.13 class 1.2 for tenant submetering and billing. They are UL Listed, certified by Underwriters Laboratory (UL) to meet the new 2017 NEC code requirement that CTs installed in the field must be UL 2808 Listed under category code XOBA.

These CTs swing open for one-handed operation. The 0750 has a window opening of 0.75" x 0.75" for current measurements up to 250 A. The 1250 has an oval-shaped window opening of 1.83" x 1.25" and is designed for loads up to 600 A.

Each CT includes 8 ft (2.4 m), twisted-pair leads; the 0750 leads are 22 AWG, and the 1250 leads are 18 AWG.

See specifications and dimensions on the following pages.

Monitoring Energy

These split-core CTs are recommended for use with the following Opto 22 products:

- *groov* EPIC® power monitoring analog input module, part number [GRV-IVAPM-3](#)



Split-Core Current Transformer, ACT-0750 Series



Split-Core Current Transformer, ACT-1250 Series

- *groov* RIO® energy monitoring edge I/O module, part number [GRV-R7-I1VAPM-3](#)
- SNAP power monitoring analog input module, part number [SNAP-AIPM-3V](#)

Part Numbers

Part	Description
OPTOEMU-ACT-0750-050	Current Transformer, Split Core, 50 A, 0.333 VAC, 0.75 inch (1.91 cm) Inner Diameter
OPTOEMU-ACT-0750-100	Current Transformer, Split Core, 100 A, 0.333 VAC, 0.75 inch (1.91 cm) Inner Diameter
OPTOEMU-ACT-0750-250	Current Transformer, Split Core, 250 A, 0.333 VAC, 0.75 inch (1.91 cm) Inner Diameter
OPTOEMU-ACT-1250-250	Current Transformer, Split Core, 250 A, 0.333 VAC, 1.83 x 1.25 inch (4.65 x 3.18 cm) Inner Opening
OPTOEMU-ACT-1250-400	Current Transformer, Split Core, 400 A, 0.333 VAC, 1.83 x 1.25 inch (4.65 x 3.18 cm) Inner Opening
OPTOEMU-ACT-1250-600	Current Transformer, Split Core, 600 A, 0.333 VAC, 1.83 x 1.25 inch (4.65 x 3.18 cm) Inner Opening

- OptoEMU Sensor™ power monitoring appliance, part number **OPTOEMU-SNR-3V**

Use with *groov* EPIC and *groov* RIO

The *groov* EPIC power monitoring module (and the *groov* RIO power monitoring module, when it is released) provide the most modern, efficient way to monitor AC voltage and current and use that data where it is needed. Both modules can monitor three-phase AC current using a 0.333 VAC current transformer (CT) or a standard current transformer.

These modules provide voltage and current field inputs plus several channels of calculated data. If the module is part of a *groov* EPIC system running a PAC Control™ strategy, strategy logic can automatically perform additional calculations and respond to any problems that the module reports.

More about *groov* EPIC

The **GRV-IVAPM-3** *groov* I/O module is part of the *groov* EPIC system for automation and industrial internet of things (IIoT) applications. It offers field inputs plus calculated channels for a total of 64 channels.

The module mounts on a *groov* EPIC chassis with a *groov* EPIC processor and other I/O modules. The processor includes software for:

- Control programming
- Configuring I/O, networking, and security
- Building a simple HMI for use on PCs and mobile devices
- Communicating data with company and cloud-based software, services, and devices

For more information on the GRV-IVAPM-3, see the [groov Power Monitoring Module Data Sheet](#) (form 2351).

More about *groov* RIO

The *groov* RIO energy monitoring edge I/O module, **GRV-R7-I1VAPM-3**, is a small-footprint, standalone unit that can be used by itself or as distributed I/O with a *groov* EPIC system. It provides 64 channels of power and energy data, 18 per phase and 10 accumulated.

Designed for IIoT applications, it includes built-in security and software to communicate data with other devices and software on premises and in the cloud. *groov* RIO even offers power over Ethernet (PoE) for easy installation.

For more information on the GRV-R7-I1VAPM-3, see the [groov RIO Energy Monitoring Unit Data Sheet](#) (form 2352).

Use with SNAP

The SNAP I/O module, **SNAP-AIPM-3V**, monitors power from a 3-phase load. The module measures voltage and current from each phase. It then calculates watts and volt-amps for each phase plus true power sums for all phases.

Part of the SNAP PAC System, the SNAP-AIPM-3V mounts on a rack with other analog, digital, and serial modules and an I/O processor. For more information, see the [SNAP Power Monitoring Modules Data Sheet](#), form 1453.

Use with the OptoEMU Sensor

The OptoEMU Sensor **OPTOEMU-SNR-3V** energy monitoring unit is an appliance that monitors the electrical energy used in your facility and then uses your existing wired or wireless Ethernet network to deliver that data to online software applications. For more information, see form 1936, the [OptoEMU Sensor 3V Data Sheet](#).

NOTE: The OptoEMU Sensor will be obsolete when current stock is depleted.

SPECIFICATIONS: ACT 0750 SERIES

	OPTOEMU-ACT-0750-050	OPTOEMU-ACT-0750-100	OPTOEMU-ACT-0750-250
Accuracy	0.75%	0.75%	0.75%
Rated Amps	50 amps	100 amps	250 amps
Accuracy Class	IEEE/ANSI C57.13, Class 1.2	IEEE/ANSI C57.13, Class 1.2	IEEE/ANSI C57.13, Class 1.2
CE Accuracy	IEC 60044-1, Class 1.0	IEC 60044-1, Class 1.0	IEC 60044-1, Class 1.0
Standard Lead Length	8 ft (2.4 m), 22 AWG	8 ft (2.4 m), 22 AWG	8 ft (2.4 m), 22 AWG
Phase Angle	± 0.50 degrees	± 0.50 degrees	± 0.50 degrees
Output Options	0.333 VAC	0.333 VAC	0.333 VAC
Operating Temperature	-40°C to 80°C	-40°C to 80°C	-40°C to 80°C
Line Frequency	50/60 Hz	50/60 Hz	50/60 Hz
CE Safety	CE	CE	CE
RoHS Compliance	Yes	Yes	Yes
UL USA	UL Listed, XOBA,UL 2808	UL Listed, XOBA,UL 2808	UL Listed, XOBA,UL 2808
UL Canada	UL Listed - XOBA7	UL Listed - XOBA7	UL Listed - XOBA7
Warranty*	5 years*	5 years*	5 years*

* Original manufacturer's warranty applies. See <https://ctlsys.com/warranty-and-return-policy/>

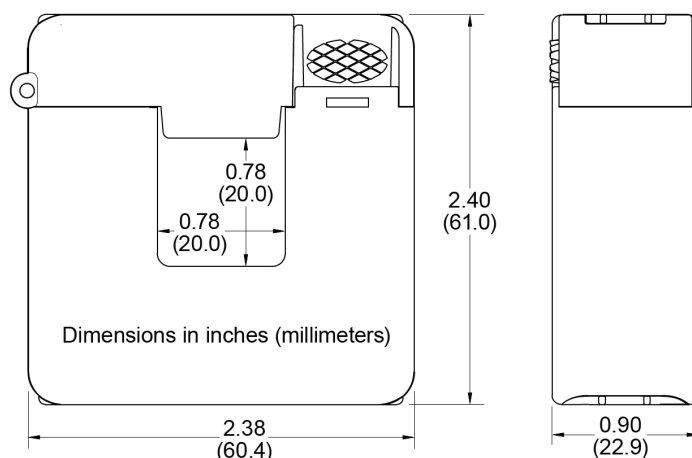

Diagram courtesy of Continental Control Systems LLC

INSTALLATION INSTRUCTIONS

WARNING: Hazardous Voltages!

Read and follow all installation instructions from the manufacturer, Continental Control Systems LLC:

[Accu-CT ACTL-0750 Split-core Current Transformer Installation Guide](#)

SPECIFICATIONS: ACT 1250 SERIES

	OPTOEMU-ACT-1250-250	OPTOEMU-ACT-1250-400	OPTOEMU-ACT-1250-600
Accuracy	0.75%	0.75%	0.75%
Rated Amps	250 amps	400 amps	600 amps
Accuracy Class	IEEE/ANSI C57.13, Class 1.2	IEEE/ANSI C57.13, Class 1.2	IEEE/ANSI C57.13, Class 1.2
CE Accuracy	IEC 60044-1, Class 1.0	IEC 60044-1, Class 1.0	IEC 60044-1, Class 1.0
Standard Lead Length	8 ft (2.4 m), 18 AWG	8 ft (2.4 m), 18 AWG	8 ft (2.4 m), 18 AWG
Phase Angle	± 0.50 degrees	± 0.50 degrees	± 0.50 degrees
Output Options	0.333 VAC	0.333 VAC	0.333 VAC
Operating Temperature	-30°C to 75°C	-30°C to 75°C	-30°C to 75°C
Line Frequency	50/60 Hz	50/60 Hz	50/60 Hz
CE Safety	CE	CE	CE
RoHS Compliance	Yes	Yes	Yes
UL USA	UL Listed, XOBA, UL 2808	UL Listed, XOBA, UL 2808	UL Listed, XOBA, UL 2808
UL Canada	UL Listed - XOBA7	UL Listed - XOBA7	UL Listed - XOBA7
Warranty*	5 years*	5 years*	5 years*

* Original manufacturer's warranty applies. See <https://cts.com/warranty-and-return-policy/>

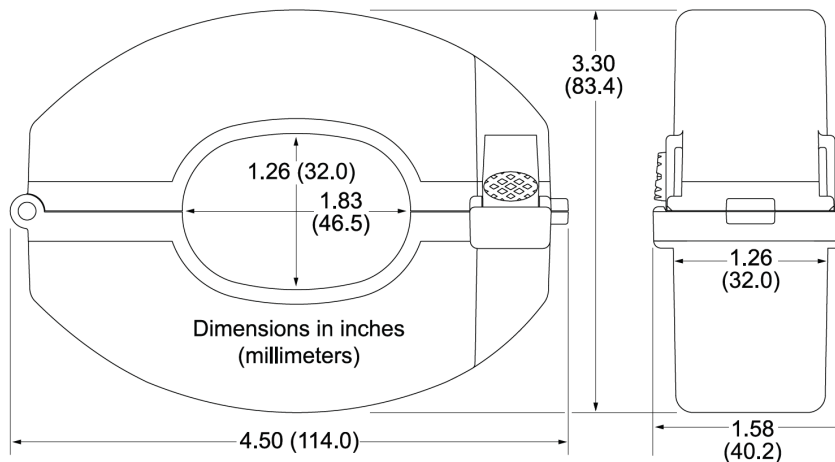

Diagram courtesy of Continental Control Systems LLC

INSTALLATION INSTRUCTIONS

WARNING: Hazardous Voltages!

Read and follow all installation instructions from the manufacturer, Continental Control Systems LLC:

[Accu-CT ACTL-1250 Series Split-core Current Transformer Installation Guide](#)

PRODUCTS

Opto 22 develops and manufactures reliable, easy-to-use, open standards-based hardware and software products. Industrial automation, process control, remote monitoring, data acquisition, and industrial internet of things (IIoT) applications worldwide all rely on Opto 22.

groov RIO®

groov RIO edge I/O offers a single, compact, PoE-powered industrial package with web-based configuration and IIoT software built in, support for multiple OT and IT protocols, and security features like a device firewall, data encryption, and user account control.

Standing alone, groov RIO connects to sensors, equipment, and legacy systems, collecting and securely publishing data from field to cloud. Choose a universal I/O model with thousands of possible field I/O configurations, with or without Ignition from Inductive Automation®, or a RIO EMU energy monitoring unit that reports 64 energy data values from 3-phase loads up to 600 VAC, Delta or Wye.

You can also use groov RIO with a Modbus/TCP master or as remote I/O for a groov EPIC system.

groov EPIC® System

Opto 22's groov Edge Programmable Industrial Controller (EPIC) system gives you industrially hardened control with a flexible Linux®-based processor with gateway functions, guaranteed-for-life I/O, and software for your automation and IIoT applications.

groov EPIC Processor

The heart of the system is the groov EPIC processor. It handles a wide range of digital, analog, and serial functions for data collection, remote monitoring, process control, and discrete and hybrid manufacturing.

In addition, the EPIC provides secure data communications among physical assets, control systems, software applications, and online services, both on premises and in the cloud. No industrial PC needed.

Configuring and troubleshooting I/O and networking is easier with the EPIC's integrated high-resolution color touchscreen. Authorized users can manage the system locally on the touchscreen, on a monitor connected via the HDMI or USB ports, or on a PC or mobile device with a web browser.

groov EPIC I/O

groov I/O connects locally to sensors and equipment. Modules have a spring-clamp terminal strip, integrated wireway, swing-away cover, and LEDs indicating module health and discrete channel status. groov I/O is hot swappable, UL Hazardous Locations approved, and ATEX compliant.

groov EPIC Software

The groov EPIC processor comes ready to run the software you need:

- Programming: Choose flowchart-based PAC Control, CODESYS Development System for IEC61131-3 compliant programs, or secure shell access (SSH) to the Linux OS for custom applications
- Node-RED for creating simple IIoT logic flows from pre-built nodes
- Efficient MQTT data communications with string or Sparkplug data formats
- HMI: groov View to build your own HMI viewable on touchscreen, PCs, and mobile devices; PAC Display for a Windows HMI; Node-RED dashboard UI
- Ignition or Ignition Edge® from Inductive Automation (requires license purchase) with OPC-UA drivers to Allen-Bradley®, Siemens®, and other control systems, and MQTT communications



Older products

From solid state relays, to world-famous G4 and SNAP I/O, to SNAP PAC controllers, older Opto 22 products are still supported and working hard at thousands of installations worldwide. You can count on us for the reliability and service you expect, now and in the future.

QUALITY

Founded in 1974, Opto 22 has established a worldwide reputation for high-quality products. All are made in the U.S.A. at our manufacturing facility in Temecula, California.

Because we test each product twice before it leaves our factory rather than testing a sample of each batch, we can afford to guarantee most solid-state relays and optically isolated I/O modules for life.

FREE PRODUCT SUPPORT

Opto 22's California-based Product Support Group offers free technical support for Opto 22 products from engineers with decades of training and experience. Support is available in English and Spanish by phone or email, Monday–Friday, 7 a.m. to 5 p.m. PST.

Support is always available on our website, including [free online training](#) at OptoU, how-to [videos](#), [user's guides](#), the Opto 22 KnowledgeBase, and [OptoForums](#).

PURCHASING OPTO 22 PRODUCTS

Opto 22 products are sold directly and through a worldwide network of distributors, partners, and system integrators. For more information, contact Opto 22 headquarters at **800-321-6786** (toll-free in the U.S. and Canada) or **+1-951-695-3000**, or visit our website at www.opto22.com.