

OutBack

POWER™

member of The  Group™

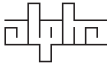
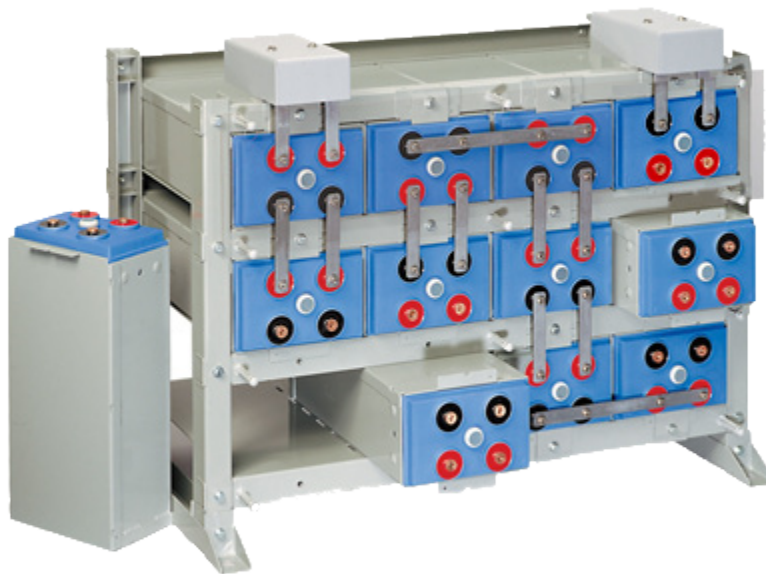

EnergyCell® RE High Capacity Battery Installation Guide and Owner's Manual

Purpose

This document provides the EnergyCell RE High Capacity Installation Guide and Operation Manual.

Scope

This document applies to all models of the EnergyCell RE High Capacity series. The reference table below shows the Outback part number cross referenced with the manufacturer part number. When using this document for installation and service operations, please refer to the manufacturer part number when referencing critical information.

Should you have ANY questions concerning how to perform the required maintenance or installation please contact Outback Power at the office number listed below and ask for Outback Power Tech Support.

EnergyCell RE High Capacity Specifications

Models:	800RE	1100RE	1300RE	1600RE	2000RE	2200RE	2700RE
EnerSys Part Number	DDm85-15	DDm85-21	DDm100-21	DDm100-25	DDm125-25	DDm100-33	DDm125-33
Nominal Voltage Per Cell	2V	2V	2V	2V	2V	2V	2V
Capacity 20Hr Rate (1.75VPC)	672	960	1148	1378	1716	1836	2288
Capacity 100Hr Rate (1.75VPC)	810	1150	1340	1600	2070	2140	2770
Watts Per Cell 15min Rate (1.67VPC)	1230	1757	1995	2394	3071	3192	4094
Cycle Life 50% DOD (25°C)	1800 cycles	1800 cycles	1800 cycles	1800 cycles	1800 cycles	1800 cycles	1800 cycles
Optimal Operating Temperature Range	23 to 26°C	23 to 26°C	23 to 26°C	23 to 26°C	23 to 26°C	23 to 26°C	23 to 26°C
OCV Per Cell Limit*	2.05	2.05	2.05	2.05	2.05	2.05	2.05
Initial Charge Voltage Per Cell**	2.27	2.27	2.27	2.27	2.27	2.27	2.27
Float Voltage Per Cell (25°C)	2.25	2.25	2.25	2.25	2.25	2.25	2.25
Float Voltage Per Cell (35°C)	2.21	2.21	2.21	2.21	2.21	2.21	2.21
Equalize Voltage Per Cell (21 to 32°C)	2.32	2.32	2.32	2.32	2.32	2.32	2.32
Maximum Charge Current (A)	148.75	212.5	250	300	375	400	500
Shelf Life (25°C)	6 months	6 months	6 months	6 months	6 months	6 months	6 months
Short Circuit Current (A)	4728	6748	7722	9267	12411	12337	16548
Internal Resistance (micro Ω)	441	309	270	225	167	169	126
Terminal Torque (Intercell Connects)	88 in-lbs						
Hardware Specification (Intercell Connects)	M8 bolt, lock and flat washer						
Weight Per Cell (lbs)	114.3	162.3	188.3	222.3	272.3	290.3	358.3
Dimensions Per Cell L x W x H (in)	21.8 x 11.9 x 6.5	21.8 x 8.4 x 6.5	24.5 x 8.4 x 6.5	24.5 x 9.9 x 6.5	23.5 x 9.9 x 8.9	24.5 x 12.9 x 6.5	23.5 x 12.9 x 8.9

Ah Capacity to 1.75VPC @ 25°C

Models:	800RE	1100RE	1300RE	1600RE	2000RE	2200RE	2700RE
1 hour	347	495	575	690	886	920	1182
2 hours	440	631	738	884	1138	1180	1518
3 hours	492	702	822	987	1260	1317	1680
4 hours	528	752	876	1052	1332	1404	1776
5 hours	555	790	920	1105	1390	1470	1850
6 hours	576	822	954	1146	1440	1524	1914
8 hours	600	864	1008	1208	1512	1616	2016
10 hours	610	870	1040	1250	1550	1660	2060
12 hours	624	888	1068	1284	1584	1704	2112
20 hours	672	960	1148	1378	1716	1836	2288
24 hours	676	984	1176	1416	1776	1872	2352
100 hours	810	1150	1340	1600	2070	2140	2770

The following PowerSafe DDM Modular Battery Systems Installation Manual is copyright 2003 by EnerSys. This document cannot be copied or reproduced without the express written permission of EnerSys Inc.



Worldwide Corporate Offices

North America
Tel: +1 360.435.6030
Fax: +1 360.435.6019

Latin America
Tel: +1 561.792.9651
Fax: +1 561.792.7157

Europe
Tel: +49 9122.79889.0
Fax: +49 9122.79889.21

Asia Pacific
Tel: +852 2736.8663
Fax: +852 2199.7988

PowerSafe

DDm

Installation Manual
PowerSafe DDM
Modular Battery Systems



PowerSafe

DDm

Installation Manual
PowerSafe DDm
Modular Battery Systems

IMPORTANT!

Read safety information first

See Safety, Storage, Operating and Maintenance Manual

The installation manual is for reference only. To maximize safety and performance, read the accompanying *Safety, Storage, Operating and Maintenance Manual* thoroughly. It provides full instructions regarding safety, storage, operation and maintenance. Failure to observe the precautions as presented may result in injury or loss of life.

Copyright ©2003 by EnerSys Inc. All rights reserved.

This document is proprietary to EnerSys Inc. This document cannot be copied or reproduced in whole or in part, nor can its contents be revealed in any manner or to any person except to meet the purpose for which it was delivered, without the express written permission of EnerSys Inc.

Please check our website for literature updates.
www.enersysinc.com

GENERAL SAFETY INSTRUCTIONS

Warnings in this manual appear in any of three ways:



Danger

The danger symbol is a lightning bolt mark enclosed in a triangle. The danger symbol is used to indicate imminently hazardous situations, locations and conditions which, if not avoided, WILL result in death, serious injury and/or severe property damage.



Warning

The warning symbol is an exclamation mark in a triangle. The warning symbol is used to indicate potentially hazardous situations and conditions, which, if not avoided COULD result in serious injury or death. Severe property damage COULD also occur.



Caution

The caution symbol is an exclamation mark enclosed in a triangle. The caution symbol is used to indicate potentially hazardous situations and conditions, which, if not avoided may result in injury. Equipment damage may also occur.

Other warning symbols may appear along with the Danger and Caution symbol and are used to specify special hazards. These warnings describe particular areas where special care and/or procedures are required in order to prevent serious injury and possible death:



Electrical warnings

The electrical warning symbol is a lightning bolt mark enclosed in a triangle. The electrical warning symbol is used to indicate high voltage locations and conditions, which may cause serious injury or death if the proper precautions are not observed.

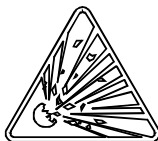

Explosion warnings

The explosion warning symbol is an explosion mark enclosed in a triangle. The explosion warning symbol is used to indicate locations and conditions where molten, exploding parts may cause serious injury or death if the proper precautions are not observed.

IMPORTANT SAFETY INSTRUCTIONS



A battery can present a risk of electrical shock and high short circuit current.

The following precautions should be observed when working with batteries.

1. Verify that the Uninterruptible Power Supply (UPS) is off and that the power cord is disconnected from the power source.
2. Remove watches, rings or other metal objects.
3. Use tools with insulated handles to prevent inadvertent shorts.
4. Wear rubber gloves and boots.
5. Do not lay tools or metal parts on top of batteries.
6. Determine if the battery is inadvertently grounded. If inadvertently grounded, remove source of ground. Contact with any part of a grounded battery can result in electrical shock. The likelihood of such shock will be reduced if such grounds are removed during installation and maintenance.
7. Verify circuit polarities before making connections.
8. Disconnect charging source and load before connecting or disconnecting terminals.
9. Valve-regulated lead-acid (VRLA) batteries contain an explosive mixture of hydrogen gas. Do not smoke, cause a flame or spark in the immediate area of the batteries. This includes static electricity from the body.
10. Use proper lifting means when moving batteries and wear all appropriate safety clothing and equipment.
11. Do not dispose of lead acid batteries except through channels in accordance with local, state and federal regulations.

IMPORTANT SAFETY INSTRUCTIONS

SAVE THESE INSTRUCTIONS

This manual contains important instructions for PowerSafe DDm Lead-Acid Battery Systems that should be followed during the installation and maintenance of the battery system.

Only a qualified EnerSys Inc. service representative who is knowledgeable in batteries and the required precautions should perform servicing of the batteries. Keep unauthorized personnel away from batteries.



Caution

Misuse of this equipment could result in human injury and equipment damage. In no event will EnerSys be responsible or liable for either indirect or consequential damage or injury that may result from the use of this equipment.



Caution

Do not dispose of the batteries in a fire. The batteries may explode.



Caution

Do not open or mutilate the batteries. Released electrolyte is harmful to the eyes and skin and may also be toxic.



Warning

This unit contains sealed lead acid batteries. Lack of preventative maintenance could result in batteries exploding and emitting gasses and/or flame. An authorized, trained technician must perform annual preventative maintenance.



Warning

Failure to replace a battery before it becomes exhausted may cause the case to crack, possibly releasing electrolyte from inside the battery and resulting in secondary faults such as odor, smoke and fire.



Warning

Installation and servicing of batteries should be performed by personnel knowledgeable about batteries and the required precautions. Keep unauthorized personnel away from the batteries.



Warning

Proper maintenance to the battery system of this unit must be done by a qualified service technician. This is essential to the safety and reliability of your Uninterruptible Power Supply (UPS) system.

IMPORTANT!

Read safety information first

See Safety, Storage, Operating and Maintenance Manual

TABLE OF CONTENTS

GENERAL SAFETY INSTRUCTIONS	i
GENERAL INFORMATION.....	2
RECOMMENDED INSTALLATION EQUIPMENT AND SUPPLIES	4
SYSTEM LAYOUT	5
Anchor Spacing	6
FRAME ASSEMBLY AND INSTALLATION	7
Base Beams	7
Vertical Channels	7
Horizontal Channels	8
Cell Support Shelves	10
BATTERY CELL INSTALLATION	11
Module Retainers	12
Electrical Bonding Instructions	12
CONNECTIONS.....	13
Terminal Plates.....	13
Inter-Cell Connectors.....	14
Terminal Bars	15
INITIAL SYSTEM READINGS	16
SAFETY SHIELDS AND COVERS	17
Safety Shields.....	17
Terminal Plate Covers	17

GENERAL INFORMATION

PowerSafe DDm battery systems are modular units that can be installed in a SINGLE STACK (figure 1), a MULTI-STACK (figure 2), or a MULTI-STACK ZERO SEPARATION (Figure 3).

Systems are available in 24, 48 and other voltage configurations. These systems allow for assembly at remote locations.

See the *ASSEMBLY DRAWING* to determine the configuration for your installation.

Before installation: Verify items received versus Bill of Lading. Verify parts against system Bill of Materials.

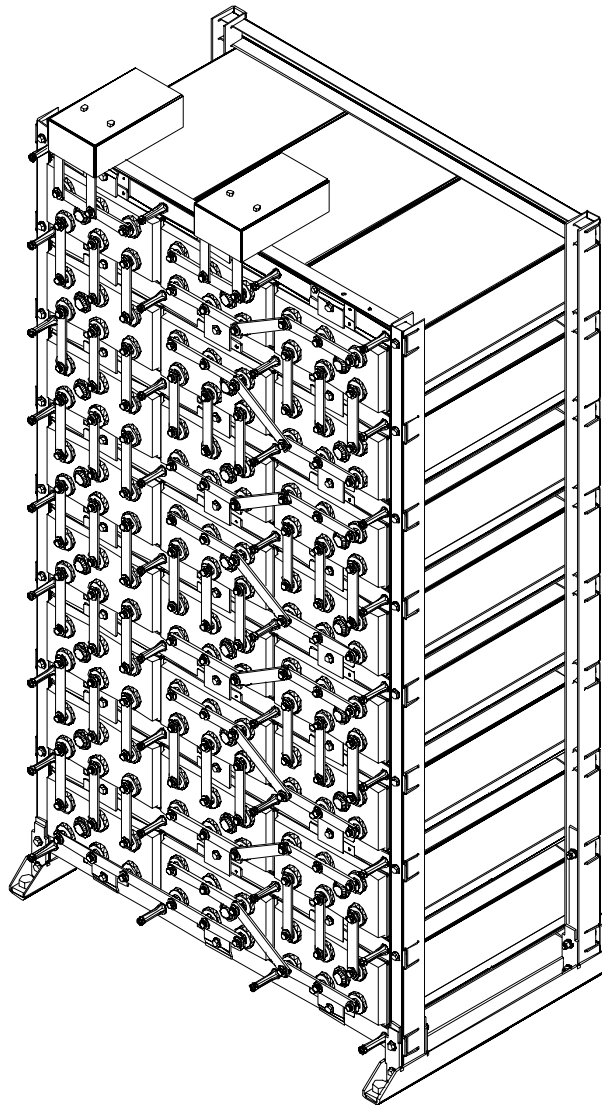

SINGLE STACK
FIGURE 1

MULTI-STACK
FIGURE 2

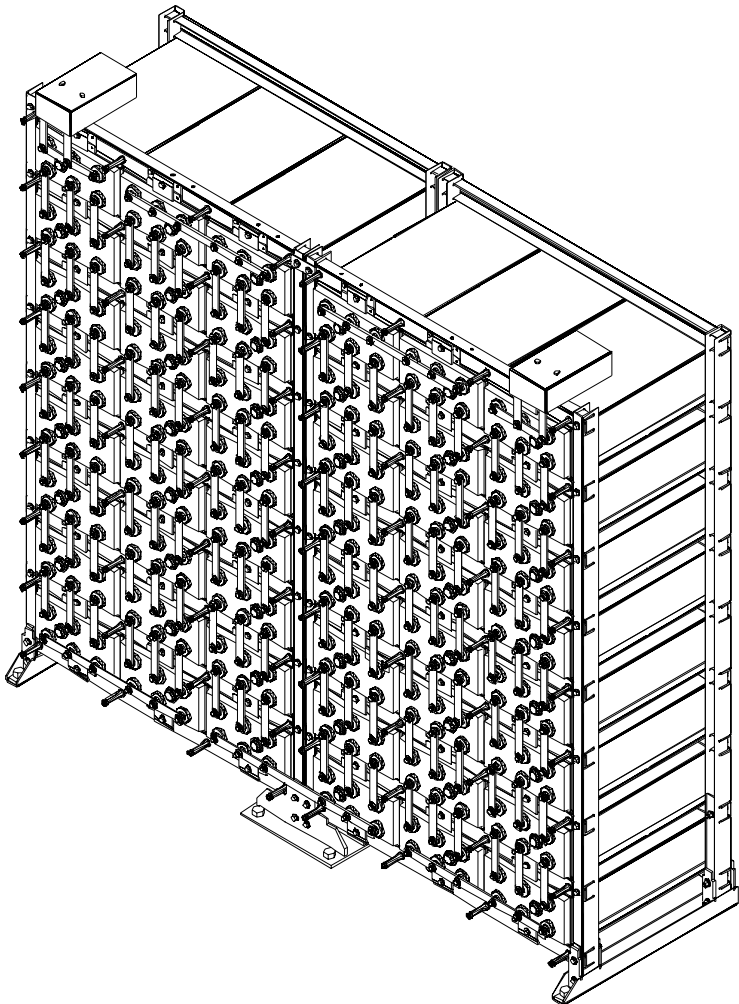
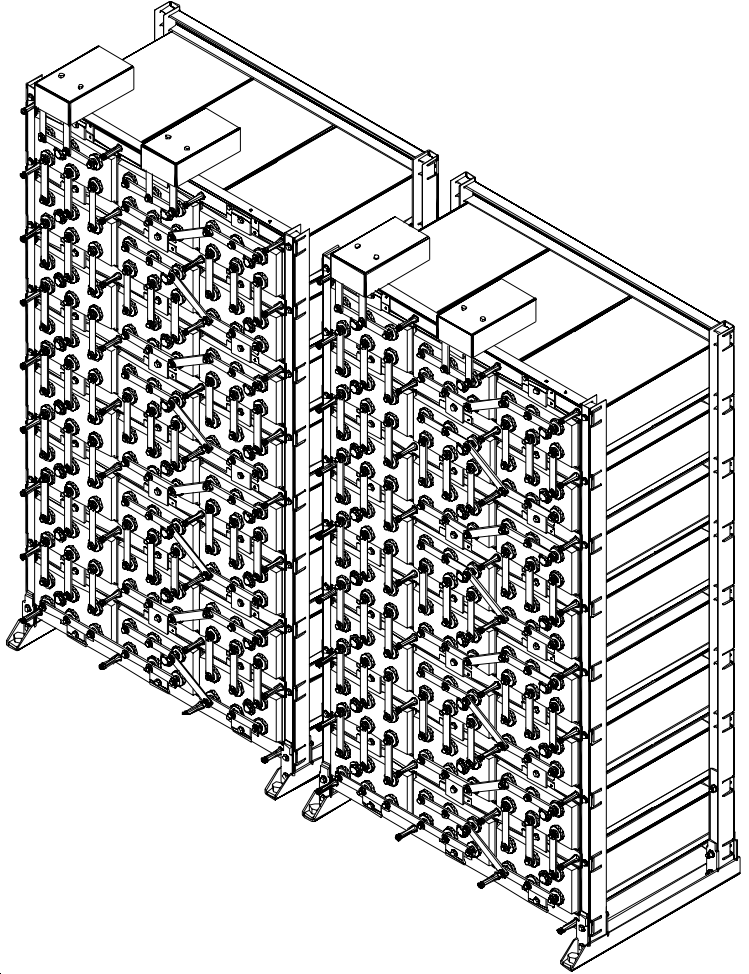

MULTI-STACK ZERO SEPARATION
FIGURE 3

RECOMMENDED INSTALLATION EQUIPMENT AND SUPPLIES

Before working with the battery system, be sure that you have the proper protective clothing, safety equipment and insulated tools as specified in the Safety, Storage, Operating and Maintenance Manual for the VRLA Modular Battery Systems.

The following is a recommended list of equipment required for installation of a PowerSafe DDm Battery System.

TABLE 1	
EQUIPMENT REQUIRED	CHECK IF ON HAND
Chalk Line	
Torpedo Level (Plastic)	
Torque Wrench (10-200 in-lbs) (SAE & Metric)	
Torque Wrench (50-100 ft-lbs) (SAE & Metric)	
Floor Anchors (User-supplied per battery system)	
Floor Shims (User-supplied)	
Drive Ratchet Wrench with Minimum 3" Extension (SAE & Metric)	
Box Wrenches (SAE & Metric)	
Screwdrivers	
Wipes, Paper or Cloth	
Stiff Bristle Nonmetallic Brush/Pad	
Tape Measure (Nonmetallic)	
Safety Equipment and Clothing	
Small Paintbrush	
Standard Allen Wrench Set	



Be sure you have all the proper protective clothing, safety tools, and equipment on hand before starting the installation.

SYSTEM LAYOUT

Before installing the battery system, lay out available floor space including aisles for installation, maintenance and possible cell replacement. Consult the local installation considerations as determined in Section 5 of the Safety, Storage, Operating and Maintenance Manual for the VRLA Modular Battery Systems. Recommended clearance between these racks and any objects (including walls and equipment) is 4 inches (102 mm).

1. Layout the system position for either a SINGLE-STACK (Figure 4), a MULTI-STACK (Figure 5), or MULTI-STACK WITH ZERO SEPARATION (Figures 6, 7 & 8) configuration with the dimensions defined in Table 2.
2. Locate the position of the floor anchors using the frame base beams.

NOTE:

- Floor anchoring is **REQUIRED** for all installations.
- Allow sufficient clearance between adjacent walls or equipment for proper installation of anchors. Please check your local codes for clearances required.
- Floor anchor design (including, but not limited to size, quantity, and capacity) and installation are the responsibility of the user/installer.
- Follow the user's design and the manufacturer's instructions.

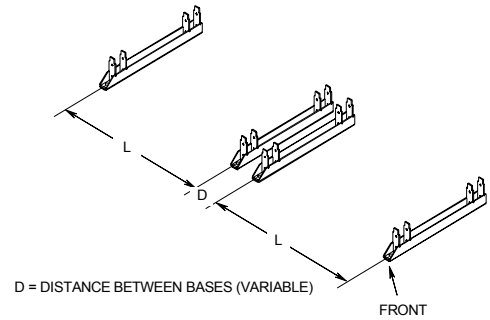

MULTI-STACK
FIGURE 5

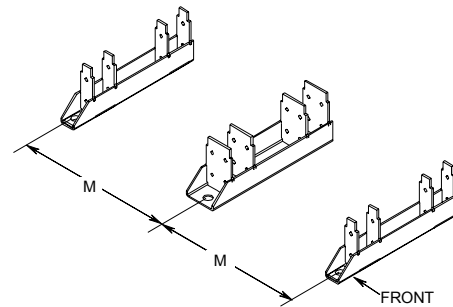

DDm50 MULTI-STACK
WITH ZERO SEPARATION
FIGURE 6

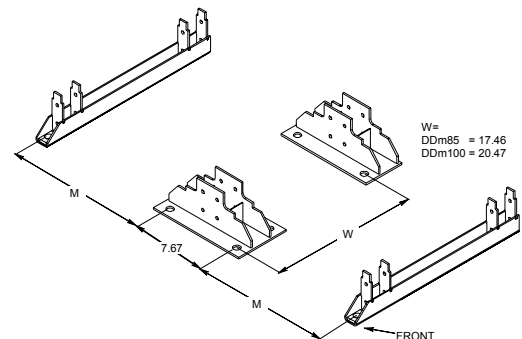

DDm85/100 MULTI-STACK
WITH ZERO SEPARATION
FIGURE 7

3. Mark floor with the position of the floor anchors.

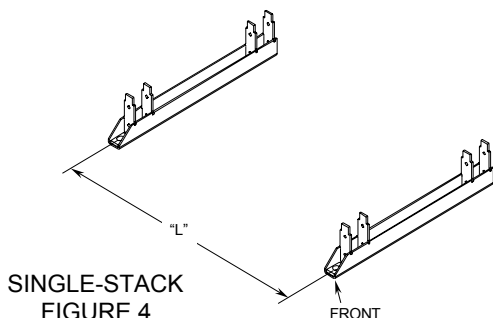

SINGLE-STACK
FIGURE 4

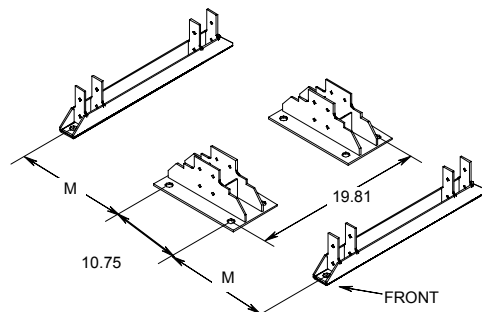

Dm125 MULTI-STACK
WITH ZERO SEPARATION
FIGURE 8

Anchor Spacing

TABLE 2
Base Beam Anchor Spacing

Cell Model	2 Cells Wide		3 Cells Wide		4 Cells Wide		6 Cells Wide		Multi-Stack w/ zero spacing	
	L (in)	L (cm)	L (in)	L (cm)	L (in)	L (cm)	L (in)	L (cm)	M (in)	M (cm)
50-09	9.04	23.0	N/A	N/A	16.52	42.0	24.01	61.0	L+0.89	L+2.3
50-13	12.04	30.6	N/A	N/A	22.52	57.2	33.01	83.8	L+0.89	L+2.3
50-17	15.49	39.3	22.48	57.1	29.26	74.3	43.17	109.7	L+0.89	L+2.3
85-13	12.04	30.6	N/A	N/A	22.52	57.2	33.01	83.8	L-2.94	L-7.5
85-15	13.54	34.4	N/A	N/A	25.52	64.8	37.51	95.3	L-2.94	L-7.5
85-21	18.48	46.9	26.93	68.4	35.26	89.6	53.71	136.4	L-2.94	L-7.5
85-25	21.48	54.6	31.43	79.8	41.26	104.8	62.68	159.2	L-2.94	L-7.5
85-27	22.98	58.4	33.69	85.6	44.27	112.4	67.22	170.7	L-2.94	L-7.5
85-33	27.48	69.8	40.43	102.7	53.26	135.3	80.71	205.0	L-2.94	L-7.5
100-21	18.48	46.9	26.93	68.4	35.26	89.6	53.71	136.4	L-2.94	L-7.5
100-25	21.48	54.6	31.43	79.8	41.26	104.8	62.68	159.2	L-2.94	L-7.5
100-27	22.98	58.4	33.69	85.6	44.27	112.4	67.22	170.7	L-2.94	L-7.5
100-33	27.48	69.8	40.43	102.7	53.26	135.3	80.71	205.0	L-2.94	L-7.5
125-25	22.09	56.1	31.88	81.0	41.98	106.6	63.29	160.8	L-4.24	L-10.8
125-27	23.59	59.9	34.14	86.7	44.98	114.2	67.83	172.3	L-4.24	L-10.8
125-33	28.09	71.3	40.88	103.8	53.98	137.1	81.32	206.6	L-4.24	L-10.8

EXAMPLE:

If you are installing a DDm85 MULTI-STACK WITH ZERO SEPARATION and you have 21 plates/cell, 4 cells wide.

$$M \text{ (inches)} = L \text{ (in)} - 2.94'' \\ 35.26'' - 2.94'' = 32.32''$$

$$M \text{ (cm)} = L \text{ (cm)} - 7.5 \text{ cm} \\ 89.6 \text{ cm} - 7.5 \text{ cm} = 82.1 \text{ cm}$$

FRAME ASSEMBLY AND INSTALLATION

To assemble and install the frame for the **PowerSafe DDm** battery system, follow the procedure below using the system layout determined in the “System Layout” section.

Base Beams

1. LEVEL with customer-supplied floor shims, and anchor in place. **Do NOT torque anchor bolts until frame assembly is complete.**
2. Install ALL base beams before continuing.

Vertical Channels

1. Insert vertical channels into base beams. See Figure 9.
2. Bolt vertical channels to base beams. Refer to below list for hardware order and Figure 10:
 - Serrated Hex Bolt (M10x1.5 – 100mm),
 - Rack Frame,
 - External Tooth Washer,
 - Flat Washer,
 - Lock Washer,
 - Hex Nut
3. Torque all connections (except anchor bolts) to 40 ft-lbs.

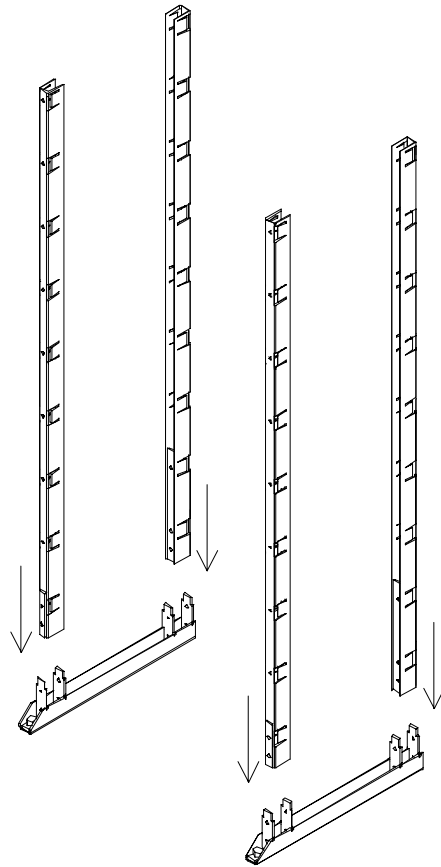

INSTALL VERTICALS
FIGURE 9

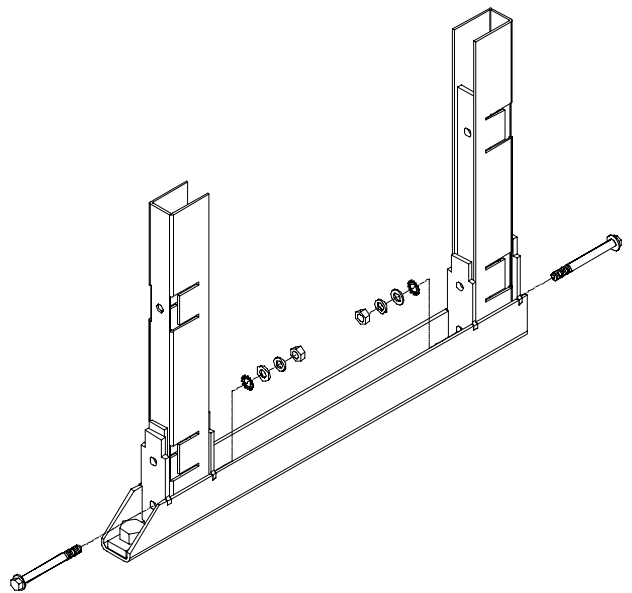

VERTICAL CHANNEL TO BASE
BEAM HARDWARE DETAIL
FIGURE 10

Horizontal Channels

NOTE:

There may be two types of horizontal channels with your shipment:

- 1) Rear – have four weld nuts
- 2) Front – have more than four weld nuts

The front horizontals are universal and, in most configurations, are substituted for the rear horizontals.

Front horizontals are to be installed with the flange positioned with the holes facing up.

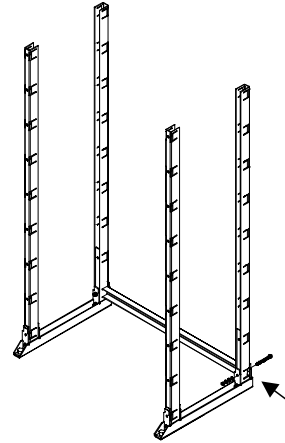

INSTALL REAR HORIZONTAL CHANNELS
FIGURE 11A

Starting at the bottom of the REAR verticals:

1. Insert REAR horizontal channels into the vertical channels. Center the horizontals between the verticals. See Figures 11a & b.
2. Bolt horizontal channels to vertical channels. Refer to below list for hardware order and Figure 12:

NOTE:

The bottom two horizontals require full thread longer bolts at the vertical channel.

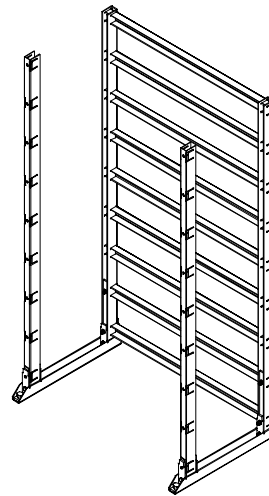

INSTALL REAR HORIZONTAL CHANNELS
FIGURE 11B

Bottom horizontal:

- Serrated Hex Bolt(M10x1.5 – 100mm Full Threads),
- Rack Frame,
- External Tooth Washer,
- Flat Washer,
- Lock Washer,
- Hex Nut

Second from bottom horizontal:

- Serrated Hex Bolt (M10x1.5 – 75mm Full Threads),
- Rack Frame,
- External Tooth Washer,
- Flat Washer,
- Lock Washer,
- Hex Nut

All other horizontals:

- Serrated Hex Bolt (M10x1.5 – 25mm)

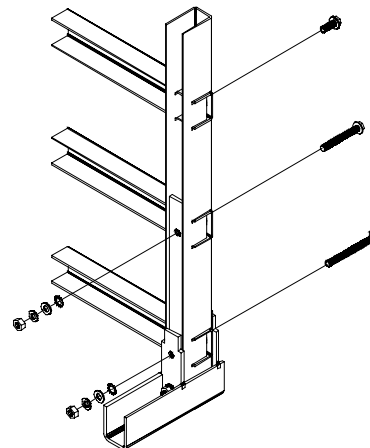

REAR HORIZONTAL CHANNEL HARDWARE DETAIL
FIGURE 12

3. Finger-tighten connections.
4. Install ALL REAR horizontals before continuing.

Starting at the bottom of the FRONT verticals:

1. Insert FRONT horizontal channels into the vertical channels. Center the horizontals between the verticals. See figures 13A & 13B.
2. Bolt horizontal channels to vertical channels. Refer to below list for hardware order and Figure 14.

NOTE:

The bottom two horizontals require full thread longer bolts at the vertical channel.

Bottom horizontal:

- Serrated Hex Bolt (M10x1.5 – 100mm Full Threads),
- Rack Frame,
- External Tooth Washer,
- Flat Washer,
- Lock Washer,
- Hex Nut

Second from bottom horizontal:

- Serrated Hex Bolt (M10x1.5 – 75mm Full Threads),
- Rack Frame,
- External Tooth Washer,
- Flat Washer,
- Lock Washer,
- Hex Nut

All other horizontals:

- Serrated Hex Bolt (M10x1.5 – 25mm)

3. Finger-tighten connections.
4. Install ALL FRONT horizontals before continuing.

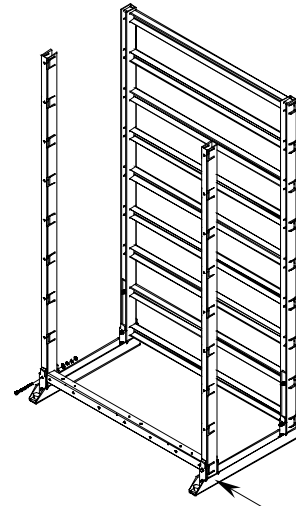

INSTALL FRONT HORIZONTAL CHANNELS
FIGURE 13A

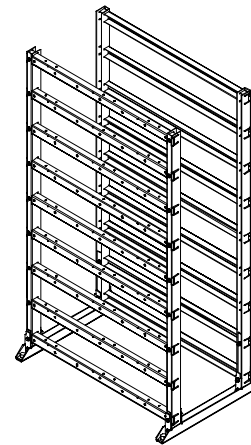

INSTALL FRONT HORIZONTAL CHANNELS
FIGURE 13B

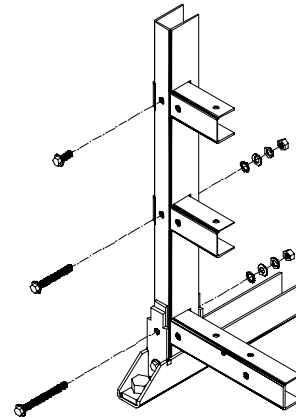

REAR HORIZONTAL CHANNEL HARDWARE
DETAIL
FIGURE 14

Cell Support Shelves

Starting at the bottom of the rack:

1. Place shelves over FRONT and REAR horizontals. See Figure 15.
2. Align holes of shelf with holes of horizontal channels. Bolt the shelf to the REAR horizontal using (2) M10x1.5 – 25mm Serrated Hex Bolts in the two OUTSIDE holes of the shelf. See Figure 16.
3. Torque these bolts to 20 ft-lbs.
4. After ALL shelves for the rack are in place, position the vertical channels so that the front and rear horizontals fit tightly against the shelves. See Figure 17.
5. Torque ALL bolts connecting the horizontals to the verticals to 20 ft-lbs.
6. If you are installing a MULTI-STACK WITH ZERO SEPARATION system, repeat Procedures 1 through 5 until all shelves are installed.

NOTE:

MULTI-STACK WITH ZERO SEPARATION systems are fastened together at the top front and top rear with a tie bar.

7. Torque all anchor bolts according to system design and manufacturer's recommendations.

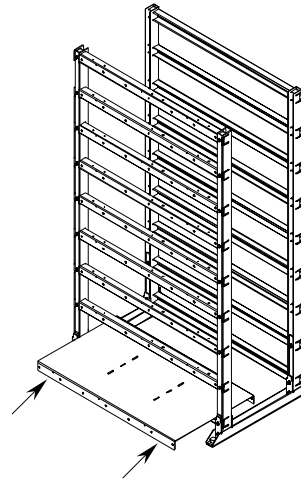

INSTALL BOTTOM CELL
SUPPORT SHELF
FIGURE 15

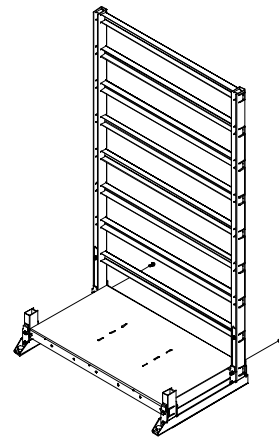

CELL SUPPORT SHELF
REAR HARDWARE
DETAIL
FIGURE 16

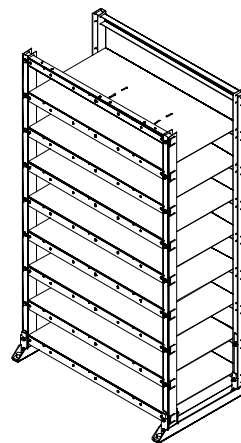

INSTALL CELL SUPPORT
SHELVES
FIGURE 17

BATTERY CELL INSTALLATION

DDm battery cells are designed for shipment and use in steel modules.

USE CAUTION WHEN HANDLING THE DDm MODULES

After a cell has been inserted into a module at the factory, a loose fit could develop because of recombination. The cell could slip very easily from the module if the module/cell is turned so that the open end of the module is lower than the closed end of the module. Serious personal injury could result if the cell slides unintentionally from the module. Keep shipping/installation retainer in place until modules are safely positioned on the shelves.

1. BEFORE installing the cells, check the voltages. The minimum acceptable cell voltage is 2.05 vpc.

If a cell has a voltage below 2.05 vpc, call your nearest EnerSys sales/service representative for resolution, or call the corporate office number listed on the back of this manual and ask for EnerSys Integrated Systems & Services.

2. Inspect each terminal for visual signs of mechanical defects.

NOTE:

Report any defects to your nearest EnerSys sales/service representative for resolution, or call the corporate office number listed on the back of this manual and ask for EnerSys Integrated Systems & Services.

If terminals are acceptable:

3. Place the FIRST DDm module onto the LOWEST EMPTY shelf, with the terminals toward the front. See Figure 18.

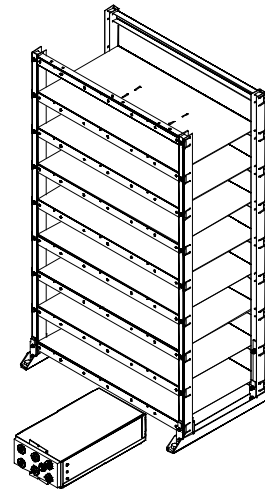

INSTALL FIRST MODULE
FIGURE 18

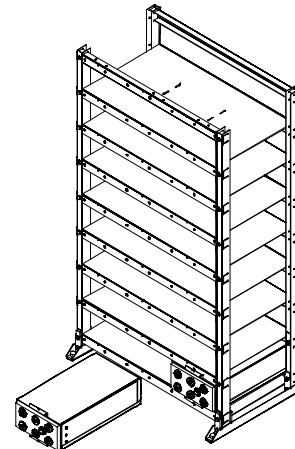

INSTALL SECOND MODULE
FIGURE 19

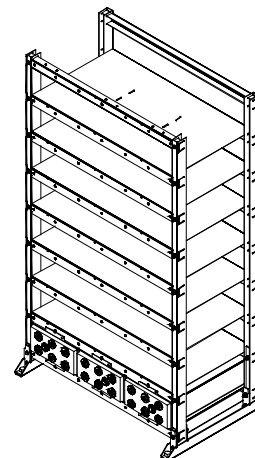

INSTALL MODULES
FIGURE 20

NOTE:

The larger modules are too heavy to lift onto the shelves manually. To avoid personal injury use appropriate lifting devices when lifting modules onto the shelves.

4. Slide the module back into a safe position. Remove the shipping retainer.
5. Slide module completely into position so the lip of the module touches the front of the shelf.
6. Place another cell onto the shelf next to the previously placed battery sleeve. Refer to the Assembly Drawing for the cell polarity configuration. See Figure 19.
7. Install remaining cells working from the lower shelves to the higher shelves. See Figures 20 and 21.

Module Retainers

1. For each battery module, install retainer plates and spacers as required, using a M10x1.5 – 25mm Serrated Hex Bolt. See Figure 22.

NOTE:

The top row of the rack requires spacers to be installed behind the upper lip of the battery modules. This spacer is fastened into place with the retainer and retainer bolt.

2. Torque to 20 ft-lbs.

Electrical Bonding Instructions

1. For each battery module, install (1) M6 Self-Tapping Screw through front lip of the battery module into the shelf/horizontal channel. See Figure 23.
2. For each retainer spacer, install (1) M6 Self-Tapping Screw through the spacer into the shelf/horizontal channel. See Figure 23.

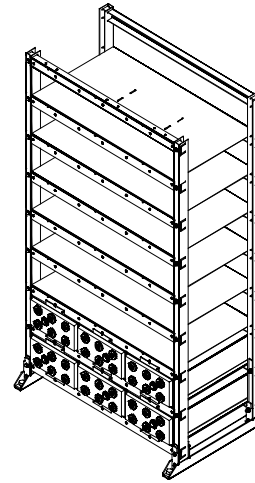

INSTALL MODULES
FIGURE 21

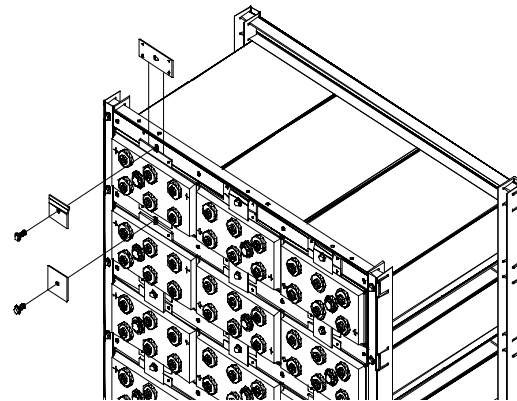

INSTALL RETAINERS
FIGURE 22

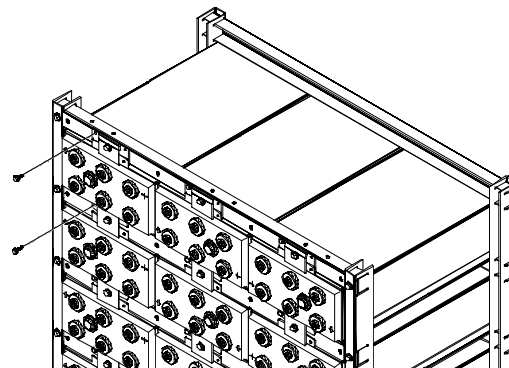

INSTALL BONDING SCREWS
FIGURE 23

CONNECTIONS

The cells are now positioned and ready to be connected. The cells must be connected according to the polarities on the *ASSEMBLY DRAWING* and the following instructions.

Before preparing and making connections, heat NO-OX-ID grease in hot water as necessary to soften for application with a paintbrush.

Terminal Plates

Terminal plates are provided with the battery system to provide a system connections point. All system connections must be made to the terminal plate and NEVER to the cell terminal. Top termination is standard, side termination is optional.

1. Clean the terminal plate electrical contact areas with a stiff-bristle nonmetallic brush/pad until the lead-plated surface is bright. Be careful not to remove the lead plating with excessive brushing.
2. Apply a light coat of heated NO-OX-ID grease to the terminal plate electrical contact area with a small paintbrush.
3. Assemble and install the terminal plate assembly finger-tight as shown in Figure 24 and 24A.
4. Check for alignment with cell terminal.
5. Torque all bolts to 15 ft-lbs.

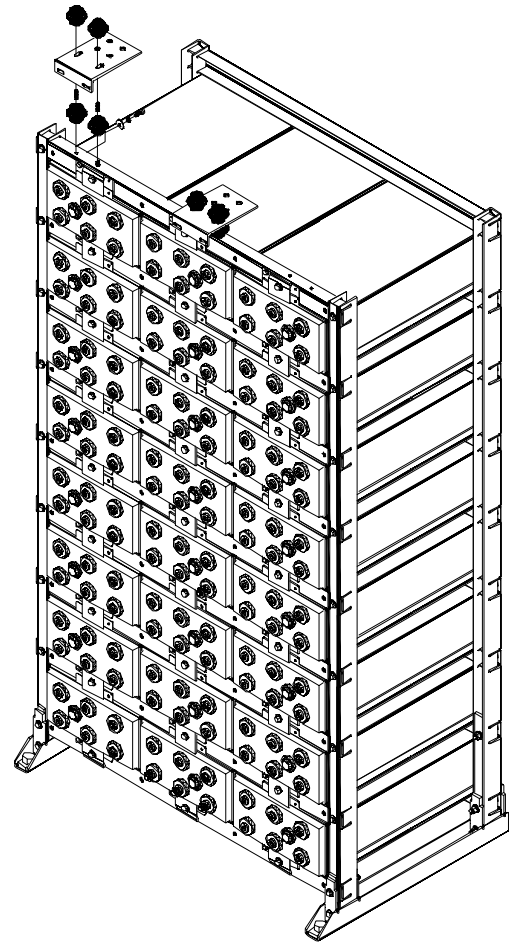

INSTALL TERMINAL PLATES
FIGURE 24

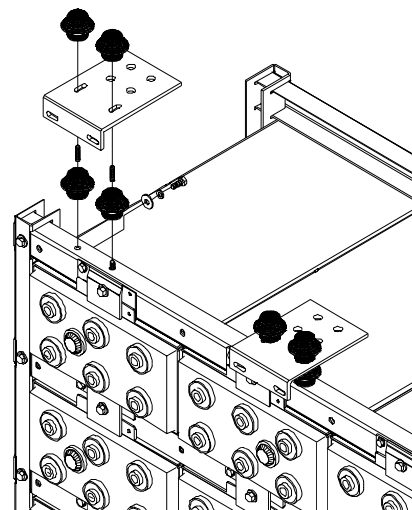

TERMINAL PLATE INSTALLATION DETAIL
FIGURE 24A

Inter-Cell Connectors

The connections are made by bolting the supplied lead-plated copper inter-cell and inter-module connectors to the cell posts of opposite polarity on adjacent cells. See *ASSEMBLY DRAWING* for details.

1. Clean the contact surface of the inter-cell connector using a stiff-bristle nonmetallic brush/pad. Be careful not to remove the lead plating with excessive brushing.
2. Apply a light coat of heated NO-OX-ID grease to the contact surface of the inter-cell connector and terminal post with a small paintbrush.
3. Bolt all inter-cell connectors according to the *ASSEMBLY DRAWING*. Assemble as the example shown in Figure 25 and below list:

Stamped flat washers may have one sharp edge. Install the washer with the sharp edge away from the lead-plated copper inter-cell connector to avoid damaging the lead plating.

- Bolt (M8)
- Lock Washer
- Flat Washer
- Inter-cell Connector
- Battery Post

NOTE:

Inter-cell connections vary in length depending on the type of connection (cell-to-cell, module-to-module, etc.) and/or stack configuration.

4. Secure all connections finger-tight to allow for some adjustment of position.
5. After all connections are completed, torque to 88 in-lbs.
6. Apply a light coat of heated NO-OX-ID grease to the bolted connection with a small paintbrush.

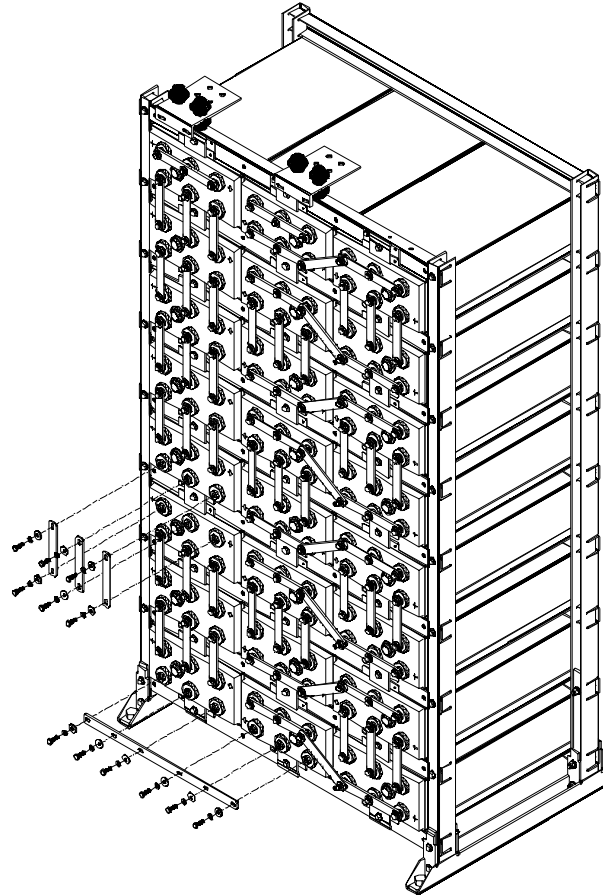

INSTALL INTERCELL
CONNECTORS
FIGURE 25

Terminal Bars

Terminal bars are supplied with the battery system to provide a cell terminal-to-terminal plate connection.

1. Inspect the system to be assured that all cells are connected correctly – POSITIVE to NEGATIVE and according to the *ASSEMBLY DRAWING*.
2. Clean the terminal bar contact area with a stiff-bristle nonmetallic brush/pad until the lead-plated surface is bright. Be careful not to remove the lead plating with excessive brushing.
3. Apply a light coat of heated NO-OX-ID grease to the terminal bar contact area with a small paintbrush.
4. Install terminal bar as shown in Figure 26.
5. Torque bolts to 88 in-lbs.
6. Apply a light coat of heated NO-OX-ID grease to the bolted connections with a small paintbrush.

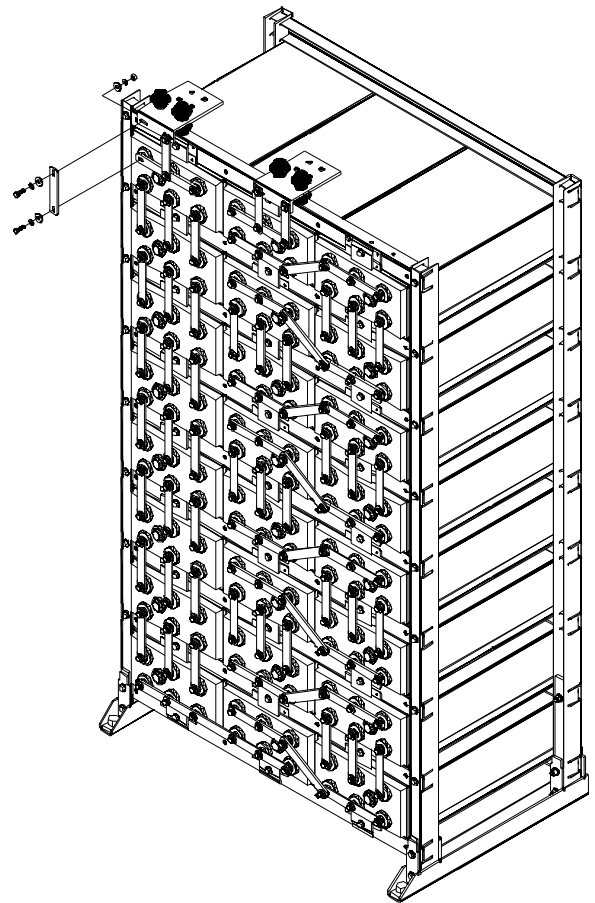

INSTALL TERMINAL BARS
FIGURE 26

INITIAL SYSTEM READINGS

Measure the **DC** system voltage across the system terminals. Voltage should equal approximately 2.15 times the number of cells in the system (See Table 3).

If the voltage is lower than 2.15 times the number of cells in the system, inspect the system to be assured that all cells are connected correctly — **POSITIVE** to **NEGATIVE** and according to the *ASSEMBLY DRAWING*.

**TABLE 3
APPROXIMATE VOLTAGE**

Number of Cells	(2.15 x number of cells)
12	25.8
24	51.6

If the voltage is persistently lower than 2.15 times the number of cells in the system, contact your EnerSys sales/service representative, or call the corporate office number listed on the back of this manual and ask for EnerSys Integrated Systems & Services.

Make a copy of the Battery Maintenance Report found in the Safety, Storage, Operating and Maintenance Manual.

Measure and record the connection resistance of “CELL to CELL” and “CELL to TERMINAL” on the copy of the report.

NOTE:

Connections made to a battery for tapping a certain group of cells to provide a voltage other than the total battery voltage is NOT recommended and can VOID THE WARRANTY. It can affect the serviceability of the battery. Tapping results in an imbalance of the system during charging and discharging and results in unsatisfactory operation.

SAFETY SHIELDS AND COVERS

Safety shields and covers are provided to help prevent accidental contact with connections after installation and during operations. Safety shields and covers should remain in place at all times during normal operation of the system. Terminal plate covers are provided as necessary to prevent accidental contact with the "live" terminal plate. Safety shields are designed to be removed for service or maintenance.

Safety Shields

1. Install ALL safety shield support posts into horizontals as shown in Figure 27.
2. Starting with bottom row, hang safety shields on support posts as shown in Figure 28.

NOTE:

The bottom of each safety shield will overlap, on the outside, the top of the shield below it.

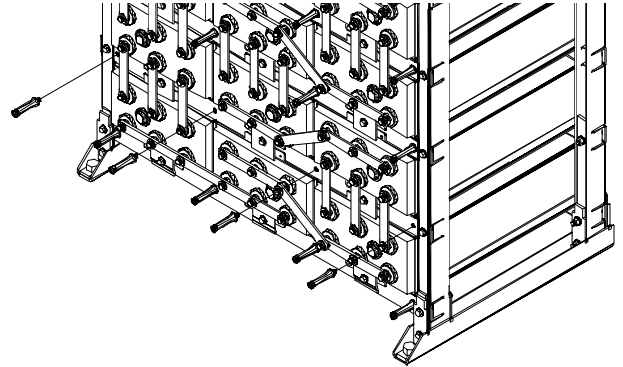

INSTALL SUPPORT POSTS
FIGURE 27

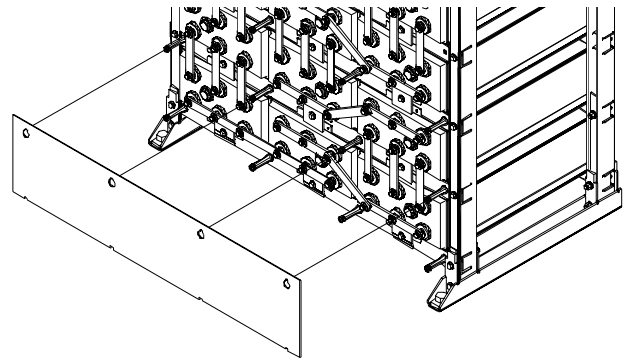

INSTALL SAFETY SHIELDS
FIGURE 28

Terminal Plate Covers

1. Connect load to the battery terminal.
2. Install terminal plate covers as shown in Figure 29.

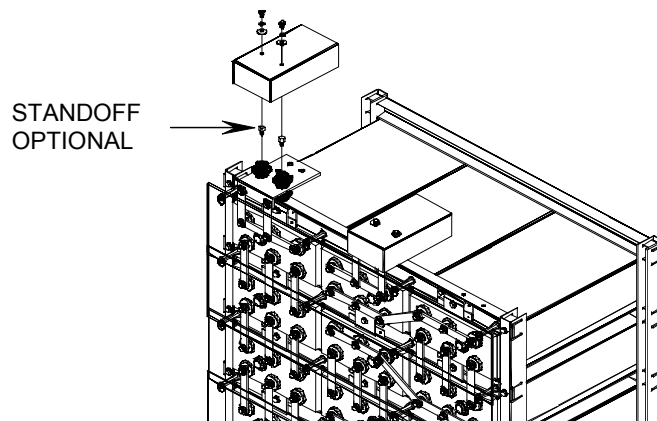

INSTALL TERMINAL PLATE COVER
FIGURE 29

NOTES

PRECAUTIONS*

1. Do Not bring any heat or flame source near battery.
2. Do Not remove pressure relief valves.



DO NOT PUSH ON CENTER
TO POSITION BATTERY

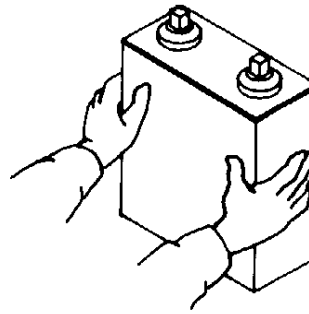

USE EDGE OF MODULE
WHEN POSITIONING BATTERY

3. Do Not lift any cells by the terminal posts.
4. Do Not tamper with seal nuts on the cell post.
5. Do Not remove lead coating from post or connectors and expose any bare copper.
6. Do Not allow cell temperature to exceed 105°F during charging.
7. Do Not clean cell with anything other than water/bicarbonate of soda.
8. Do Not over torque connections.
9. Do Not store PowerSafe DDm type batteries for over six months without charge, at normal temperatures.

* These are only a few of the precautions. Please read all accompanying literature thoroughly for specific safety and installation information.

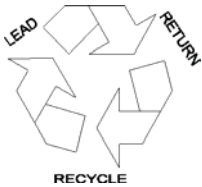

When ordering new batteries, also remember to properly recycle your old lead batteries. Federal and state regulations require lead-acid batteries be recycled. EnerSys' nationwide service organization can arrange pickup, transportation to and recycling at any one of our company affiliated smelters. Call 1-800-972-7372 for more information.



Please check our website for literature updates.



www.enersysinc.com

EnerSys Inc.
P.O. Box 14145
Reading, PA 19612-4145
USA
Tel: +1-610-208-1991
+1-800-538-3627

EnerSys EMEA
Brussels, Belgium
Tel: +32 (0)2 247 94 47
EnerSys Asia
Guangdong, China
Tel: +86 755 2689 3639

Represented by:



Safety, Storage, Operating and
Maintenance Manual

VRLA Battery Systems
mSeries, DDm, DDS, DGX, DDV
and SC





Safety, Storage, Operating and
Maintenance Manual

VRLA Battery Systems
mSeries, DDm, DDS, DGX, DDV
and SC

When working with any EnerSys® Modular Battery System, be sure to refer to the Installation Manual specified for that system and Rack Assembly Instructions included in the rack shipment.

This manual provides full instructions regarding safety, storage, operation, and maintenance for EnerSys® valve-regulated lead acid batteries, as well as certain installation considerations. To maximize safety and performance, read the accompanying *Installation Manual* thoroughly. Failure to observe the precautions as presented may result in injury or loss of life.

© 2008 by EnerSys. All rights reserved.

This document is proprietary to EnerSys. This document cannot be copied or reproduced in whole or in part, without the express written permission of EnerSys.

Please check our website for literature updates.
www.enersys.com

GENERAL SAFETY INSTRUCTIONS

Warnings in this manual appear in any of three ways:



Danger

The danger symbol is a lightning bolt mark enclosed in a triangle. The danger symbol is used to indicate imminently hazardous situations, locations and conditions which, if not avoided, WILL result in death, serious injury and/or severe property damage.



Warning

The warning symbol is an exclamation mark in a triangle. The warning symbol is used to indicate potentially hazardous situations and conditions, which if not avoided COULD result in serious injury or death. Severe property damage COULD also occur.



Caution

The caution symbol is an exclamation mark enclosed in a triangle. The caution symbol is used to indicate potentially hazardous situations and conditions, which if not avoided may result in injury. Equipment damage may also occur.

Other warning symbols may appear along with the Danger and Caution symbol and are used to specify special hazards. These warnings describe particular areas where special care and/or procedures are required in order to prevent serious injury and possible death:



Electrical warnings

The electrical warning symbol is a lightning bolt mark enclosed in a triangle. The electrical warning symbol is used to indicate high voltage locations and conditions, which may cause serious injury or death if the proper precautions are not observed.



Explosion warnings

The explosion warning symbol is an explosion mark enclosed in a triangle. The explosion warning symbol is used to indicate locations and conditions where molten, exploding parts may cause serious injury or death if the proper precautions are not observed.

IMPORTANT SAFETY INSTRUCTIONS



DANGER

A battery can present a risk of electrical shock and high short circuit current.

The following precautions should be observed when working with batteries.

1. Verify that the Uninterruptible Power Supply (UPS) is off and that power cord is disconnected from the power source.
2. Remove watches, rings or other metal objects.
3. Use tools with insulated handles to prevent inadvertant shorts.
4. Wear rubber gloves and boots.
5. Do not lay tools or metal parts on top of batteries.
6. Determine if the battery is inadvertently grounded. If inadvertently grounded, remove source of ground. Contact with any part of a grounded battery can result in electrical shock. The likelihood of such shock will be reduced if such grounds are removed during installation and maintenance.
7. Verify circuit polarities before making connections.
8. Disconnect charging source and load before connecting or disconnecting terminals.
9. Valve-regulated lead-acid (VRLA) batteries contain an explosive mixture of hydrogen gas. Do not smoke, cause a flame or spark in the immediate area of the batteries. This includes static electricity from the body.
10. Use proper lifting means when moving batteries and wear all appropriate safety clothing and equipment.
11. Do not dispose of lead acid batteries except through channels in accordance with local, state and federal regulations.

IMPORTANT SAFETY INSTRUCTIONS

SAVE THESE INSTRUCTIONS

This manual contains important instructions for PowerSafe™ mSeries Lead-Acid Battery Systems that should be followed during the installation and maintenance of the battery system.

Only a qualified EnerSys® service representative who is knowledgeable in batteries and the required precautions should perform servicing of the batteries. Keep unauthorized personnel away from batteries.



CAUTION

Misuse of this equipment could result in human injury and equipment damage. In no event will EnerSys be responsible or liable for either indirect or consequential damage or injury that may result from the use of this equipment.



CAUTION

Do not dispose of the batteries in a fire. The batteries may explode.



CAUTION

Do not open or mutilate the batteries. Released electrolyte is harmful to the eyes and skin and may also be toxic.



WARNING

This unit contains sealed lead acid batteries. Lack of preventative maintenance could result in batteries exploding and emitting gasses and/or flame. An authorized, trained technician must perform annual preventative maintenance.



WARNING

Failure to replace a battery before it becomes exhausted may cause the case to crack, possibly releasing electrolyte from inside the battery and resulting in secondary faults such as odor, smoke and fire.



WARNING

Installation and servicing of batteries should be performed by personnel knowledgeable about batteries and the required precautions. Keep unauthorized personnel away from the batteries.



WARNING

Proper maintenance to the battery system of this unit must be done by a qualified service technician. This is essential to the safety and reliability of your Uninterruptible Power Supply (UPS) system.

When working with any EnerSys® Modular Battery System, be sure to refer to the Installation Manual specified for that system and Rack Assembly Instructions included in the rack shipment.

TABLE OF CONTENTS

GENERAL SAFETY INSTRUCTIONS	i
1.0 GENERAL INFORMATION	1
1.1 Introduction	1
1.2 Precautions	1
1.3 Service	2
2.0 SAFETY	3
2.1 General	3
2.2 Safety Equipment and Clothing	3
2.3 Safety Precautions	4
2.3.1 Sulfuric Acid Burns	4
2.3.2 Explosive Gases	5
2.3.3 Electrical Shocks and Burns	5
3.0 INSPECTING THE BATTERY SHIPMENT	7
3.1 General	7
3.2 Visible External Damage	7
3.3 Concealed Damage	8
4.0 BATTERY STORAGE BEFORE INSTALLATION	9
4.1 General	9
4.2 Storage Location	9
4.3 Advance Preparation	10
5.0 INSTALLATION CONSIDERATIONS	11
5.1 General	11
5.2 Considerations for Connecting the Battery System to Operating Equipment	12
5.3 Considerations for Parallel Installation	13
6.0 UNPACKING AND HANDLING FOR INSTALLATION	14
6.1 General	14
6.2 Accessories	14
6.3 Recommended Installation Equipment and Supplies	15
7.0 INITIAL and/or FRESHENING CHARGE	16
8.0 OPERATION	17
8.1 General	17
8.1.1 Determining the State-of-Charge	17
8.2 Float Operation	18
8.2.1 Float Charge Method	19
8.3 Equalizing Charge	20
8.3.1 Equalizing Charge Method	21

9.0 BATTERY TAPS	22
10.0 PILOT CELL	22
11.0 MAINTENANCE	22
11.1 Battery Cleaning	22
11.1.1 Standard Cleaning	22
11.1.2 Corrosion Cleaning	23
11.1.3 Heavy Corrosion Cleaning	23
11.2 Test Procedures	24
11.2.1 Procedure for Battery Capacity Tests	24
11.3 Maintenance Records	26
12.0 TEMPORARY NON-USE (EXTENDED OUTAGE)	29
12.1 Installed/Out-of-Service-System	29
12.2 Return to Service	29

1.0 GENERAL INFORMATION

1.1 Introduction

EnerSys® modular valve-regulated lead acid (VRLA) batteries have unique features that make them easy to install and maintain. These batteries are composed of absorbed glass mat (AGM) separators with flat plates and/or gelled electrolyte with tubular positive plates.

The AGM retains the acid between the plates to ensure long float service. In the case of gelled acid, the acid is retained in a gel medium; thus, maximum contact with the plates ensures long float service in cycling applications. Furthermore, the tubular positive plate design holds the active material in position, providing excellent high cycling ability (1200 cycles to 80% DOD). Both utilize gas recombinant technology to minimize maintenance.

PowerSafe™ batteries utilize calcium alloy grids (NO cadmium) which float at a lower current than antimony (Sb). Lower float currents, in conjunction with superior and uniform thermal management, reduce the chances of thermal runaway. (Temperature compensation chargers are also recommended.)

PowerSafe VRLA batteries typically do not require special battery rooms because excess hydrogen is not emitted under normal operating conditions. In addition, the modules make installation fast and easy.

1.2 Precautions

BEFORE UNPACKING, STORING, HANDLING, INSTALLING, OPERATING OR PERFORMING MAINTENANCE ON THE ENERSYS VRLA BATTERY SYSTEM:

**READ
THE FOLLOWING
INFORMATION THOROUGHLY!**

It is important to read, understand and strictly follow the instructions in this manual.

If the following precautions are not fully understood, or if local conditions are not covered, contact your nearest EnerSys sales/service representative for clarification or call the corporate office number listed on the back of this manual and ask for EnerSys Reserve Power Service.

Also, refer to all applicable federal, state and local regulations and industry standards.

YOU SHOULD BE TRAINED IN HANDLING, INSTALLING, OPERATING AND MAINTAINING BATTERIES BEFORE YOU WORK ON ANY BATTERY SYSTEM.

1.3 Service

Should you require installation supervision, service, parts, accessories or maintenance; EnerSys® has a nationwide service organization to assist with your new battery purchase.

Please call your nearest EnerSys sales/service representative for more information or call the corporate office number listed on the back of this manual and ask for EnerSys Reserve Power Service.



2.0 SAFETY

2.1 General

PowerSafe™ valve-regulated lead acid batteries are reduced-maintenance batteries that operate on recombinant principles and are safer than conventional "wet cell" lead-acid batteries.

Under **NORMAL** operating conditions and use, their design features:

- minimize hydrogen gas release
- virtually eliminate acid misting
- essentially eliminate leakage

Under **ABNORMAL** operating conditions or as a result of damage, abuse and/or misuse, the potentially hazardous conditions of hydrogen gassing, acid misting and leakage may occur.

YOU SHOULD BE **TRAINED** IN HANDLING, INSTALLING, OPERATING AND MAINTAINING BATTERIES BEFORE YOU WORK ON ANY BATTERY SYSTEM.

You MUST understand the risk of working with batteries and BE PREPARED and EQUIPPED to take the necessary safety precautions. If not, contact EnerSys® Reserve Power Service.

2.1 Safety Equipment and Clothing

When working with any battery system, be sure you have the necessary tools and safety equipment, including but not limited to:

- insulated tools
- rubber apron
- face shields
- rubber gloves
- safety goggles
- emergency eye wash
- fire extinguisher
- acid spill cleanup kit
- and shower, if available

ALWAYS:

- remove all jewelry (i.e., rings, watches, chains, etc.)
- keep sparks, flames and smoking materials away from the battery



NEVER lay tools or other metallic objects on the battery modules.

Using the correct tools and wearing proper safety equipment will help prevent injury should an accident occur.



2.3 Safety Precautions

2.3.1 Sulfuric Acid Burns

Because VRLA cells are sealed, they normally do not present an acid danger. However, they do contain sulfuric acid, which can cause burns and other serious injuries.

Always wear protective clothing AND use the correct safety tools.

In case of **SKIN CONTACT** with sulfuric acid, **IMMEDIATELY**

1. **REMOVE** contaminated **CLOTHING**
2. **FLUSH** the area **THOROUGHLY** with **WATER**
3. Get **MEDICAL ATTENTION**, if required.

In case of **EYE CONTACT** with sulfuric acid, **IMMEDIATELY**

1. **FLUSH THOROUGHLY** for at least 15 minutes with large amounts of **WATER**.
2. Get **MEDICAL ATTENTION**.

In case of sulfuric acid **CONTACT WITH CLOTHING OR MATERIAL**, **IMMEDIATELY**

1. **REMOVE** CONTAMINATED CLOTHING
2. Apply a solution of sodium bicarbonate solution (1.0lb/1.0gal or 0.5 kg/5.0 liters of water) on the clothing or material.
3. Apply the solution until bubbling stops, then rinse with clean water.

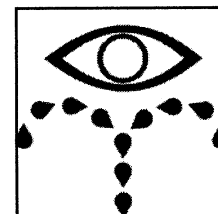
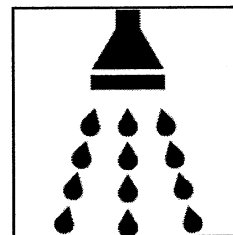
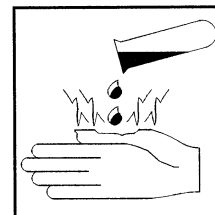

NOTE: In case of a sulfuric acid **SPILL**, bicarbonate of soda or an emergency spill kit should be within the battery room in accordance with OSHA regulations 1910.178g2.

2.3.2 Explosive Gases

Batteries can generate gases, which when released can explode, causing blindness and other serious personal injury.

Always wear protective clothing and use the correct safety tools.

Eliminate any potential of sparks, flames or arcing.



IN CASE OF FIRE: To extinguish a fire in a battery room containing lead-acid batteries, use a CO₂, foam or dry-chemical extinguishing medium. Do NOT discharge the extinguisher directly onto the battery. The resulting thermal shock may cause cracking of the battery case/cover.

SPECIAL PROCEDURES:

If batteries are on charge, shut off power. Use positive-pressure, self-contained breathing apparatus. Wear acid resistant clothing. Water applied to electrolyte generates heat and causes it to splatter.

TOXIC FUMES:

Burning plastic may cause toxic fumes. Leave area as soon as possible if toxic fumes are present. Wear breathing apparatus if required to remain in the area.

2.3.3 Electrical Shocks and Burns

Multi-cell battery systems can attain high voltage and/or currents. Do NOT touch uninsulated batteries, connectors or terminals. To prevent serious electrical burns and shock, use EXTREME CAUTION when working with the system.

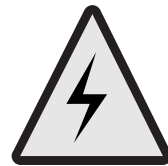

Always wear protective clothing and use nonconductive or insulated safety tools when working with ANY battery system.

Remove all jewelry that could produce a short circuit.

BEFORE working on the system:

1. Disconnect ALL loads and power sources to the battery. Use appropriate lockout/tagout procedures.
2. If working on an assembled battery system, sectionalize (interrupt the battery sections) into safe working voltage levels.
3. Check the battery system grounding. Grounding of the battery system is NOT recommended. However, grounding of the rack is recommended.

IF BATTERY SYSTEM IS GROUNDED: (system is intentionally grounded by connecting a battery terminal to ground)



1. An increased shock hazard exists between the terminal of opposite polarity and ground, (i.e., dirt and acid on top of battery cell touching rack).



2. If an unintentional ground develops within the already grounded system, a short circuit may occur and cause explosion or fire.

IF BATTERY SYSTEM IS GROUNDED:



1. If an unintentional ground develops within the system, an increased shock hazard exists between the terminal of opposite polarity and ground.



2. If a second unintentional ground develops within the already unintentionally grounded system, a short circuit may occur and cause explosion or fire.

Therefore, should you be required to work on a grounded battery system, make absolutely sure you use the correct safety precautions, equipment and clothing.

IMPORTANT

If you have ANY questions concerning safety when working with the battery system, contact your nearest EnerSys® sales/service representative to clarify any of the noted safety precautions, or call the corporate office number listed on the back of this manual and ask for EnerSys Reserve Power Service.

3.0 INSPECTING THE BATTERY SHIPMENT

3.1 General

Precautions have been taken to pack the battery units, individual cells or cabinets containing batteries for shipment to ensure their safe arrival. However, upon receipt, you should inspect for evidence of damage that may have occurred during transit.



WARNING
During inspections, take precautions against electrical shock.
You are handling LIVE batteries.

3.2 Visible External Damage

IMMEDIATELY upon delivery (while the carrier representative is still on-site), inventory all materials against the Bill of Lading and inspect for visible external damage.

Check material quantities received against the Bill of Lading, including the number of battery pallets and the number of accessory boxes.

Note any:

- damage to packing material.
- wetness or stains, indicating electrolyte leakage.

If damage is noted:

1. Make a descriptive notation on the delivery receipt before signing.
2. Request an inspection by the carrier.
3. File a damage report.

3.3 Concealed Damage

Within **15 days of receipt**, unpack the cells/batteries and check for concealed damage. Remember, you are handling a **LIVE** battery. Take precaution against a shock hazard. Follow all safety precautions as noted in Section 2.0.



Note any:

- damage to packing material.
- wetness or stains, indicating electrolyte leakage.

If damage is noted:

1. Request an inspection by the carrier.
2. File a concealed-damage claim.

Check the received materials against the detailed packing list to verify receipt of all materials in the quantities specified.

For export, the cells may be packed in wooden boxes which must be opened completely and carefully, and the cells then handled as described hereafter. See Section 6 for unpacking and handling.

DELAY IN NOTIFYING THE CARRIER MAY RESULT IN LOSS OF YOUR RIGHT TO REIMBURSEMENT FOR DAMAGES. Refer to the Bill of Lading, if, when performing the parts inventory, you are unsure about the appearance of a part.

If you have any questions concerning potential damages, contact your nearest EnerSys® sales/ service representative, or call the corporate office number listed on the back of this manual and ask for EnerSys Reserve Power Service.

4.0 BATTERY STORAGE BEFORE INSTALLATION

4.1 General

Batteries should be unpacked, installed and charged as soon as possible after receipt. However, if this is impractical, follow the instructions below for storing the battery before installation.

4.2 Storage Location

1. Store batteries indoors in a clean, dry and cool location. Storage at higher temperatures will result in accelerated rates of self-discharge and possible deterioration of battery performance and life.



2. Do **NOT** stack pallets. **DAMAGE MAY OCCUR AND THE WARRANTY MAY BE VOIDED.**

3. The maximum storage time from shipment to initial charge is six months for batteries stored at ambient temperatures no warmer than 77°F (25°C). For storage temperatures greater than 77°F (25°C), the battery must be recharged one (1) month sooner for every 5°F (3°C) increase above 77°F (25°C). See Table 4.1.

TABLE 4.1	
STORAGE TEMPERATURE	STORAGE TIME
32°F (0°C) to 50°F (10°C)	9 months
51°F (11°C) to 77°F (25°C)	6 months
78°F (26°C) to 92°F (33°C)	3 months

If storage time exceeds the storage time recommended in Table 4.1, give the battery a freshening charge before the end of the recommended storage interval. See Section 7 for charging information.

PowerSafe™ VRLA mSeries, DDm, DDS and DDV batteries must be charged in the horizontal position. Charging in the vertical position could void the warranty.

4. Repeat the *freshening charge* for each additional storage interval until the battery is installed.

Storage at higher temperatures will result in accelerated rates of self-discharge and possible deterioration of battery performance and life. Storage times exceeding the above may result in plate sulfation, which may adversely affect electrical performance and expected life.

5. Maximum total storage time prior to installation is two (2) years from date of shipment from the factory to the customer. *Freshening charges* are required before the end of the storage time period, or more frequently, as noted in Table 4.1.

6. FAILURE TO CHARGE AS NOTED VOIDS THE BATTERY'S WARRANTY.

4.3 Advanced Preparation

If storage time is likely to be exceeded, make advance preparation to have an adequate charger available and adjacent to an appropriate AC supply voltage. Positioning of the cells to accept temporary intercell connectors is another consideration of advance planning. Keep cells on styrofoam pads until the cells are installed on the rack (when applicable).

Make every effort to get the battery connected to the charger before expiration of the storage period, thereby avoiding the additional labor cost of preliminary freshening charges.



WARNING

Failure To Charge As Noted Voids The Battery's Warranty



**BEFORE INSTALLATION
READ THIS SECTION THOROUGHLY.**

5.0 INSTALLATION CONSIDERATIONS

5.1 General

If you have any questions concerning the installation considerations, contact your EnerSys® sales/service representative for clarification or call the corporate office number listed on the back of this manual and ask for EnerSys Reserve Power Service.

When planning the system space requirements, consider the following:

- space
- environment
- temperature
- distance from operating equipment
- ventilation
- battery system configuration
- floor loading
- floor anchoring

Table 5.1 will assist you to ensure that all requirements for installation location are considered.

TABLE 5.1	
CONSIDERATION	RECOMMENDATION
Space	<p>Aisle space should be in accordance with the National Electric Code (NEC) Article 110-16 or local codes.</p> <p>Clearance from wall/equipment - 4" (10 cm) minimum</p>
Environment	<p>Clean, cool and dry. The location should be selected to keep water, oil, and dirt away from all cells.</p>
Temperature	<p>Ambient temperature between 72°-78°F (23°-26°C)</p> <p>Elevated temperatures reduce operating life. Lower temperatures reduce battery performance.</p> <p>Minimize temperature variations between the cells. (To avoid temperature variation between the cells, do NOT locate the battery near HVAC ducts or exhausts, heats sources (i.e., equipment that generates heat) or direct sunlight.</p>

TABLE 5.1 (continued)

CONSIDERATION	RECOMMENDATION
Ventilation	No special battery room or ventilation is required. However, do NOT install in an airtight enclosure.
Grounding	It is recommended that the modules or racks be grounded in accordance with NEC and/or local codes.
Floor	Reasonably level. Shimming up to 1/4" (6mm) maximum to level battery front to rear and side to side. Capable of supporting the weight of the battery as well as any auxiliary equipment.
Anchoring	<p>All installations should be floor anchored. Anchoring should meet all local, state, federal codes and industry standards.</p> <p>Floor anchoring and its design are the responsibility of the installer.</p> <p>Ensure seismic requirements are considered.</p>
Proximity to Electronic Equipment	PowerSafe™ VRLA batteries may be installed next to electronic equipment, unless it generates heat.

5.2 Considerations for Connecting the Battery System to Operating Equipment

The battery has been sized based on a specific load (amps or KW) for a specific run time to a specific end voltage. Consult with the system/equipment supplier to determine these parameters, because battery performance is based on these values, which are measured at the battery terminals.

Therefore, ensure that the load cables:

- between the battery and its load are the shortest routing possible to the terminal, allowing sufficient additional cable (about 6" [15 cm]) for connect/disconnect.
- are the proper size to minimize the voltage drop between the battery output terminals and the load.
- are connected to the terminal plate (NEVER connect the load cable(s) directly to the battery terminal).

To select the proper cable size:

1. Determine the cable size necessary to carry the design load.
2. Calculate the voltage drop of the cable between the battery terminal plate and the operating equipment.
3. Increase cable size to achieve the allowable voltage drop.

Cable selection should provide no greater voltage drop than required between the battery system and the operating equipment as determined by the equipment/system supplier. Excessive voltage drop will reduce the desired support time of the battery system.

5.3 Considerations for Parallel Installation

If it is necessary to connect the battery system in parallel to obtain sufficient capacity, cable connections to each of the parallel strings are important. If parallel connection is required, do NOT exceed five strings in parallel.

To obtain proper load sharing on the discharge, satisfactory recharge, and the same float voltage for each string, cables from the batteries to the load must be:

- as short as possible (equal to the longest intercell connector).
- of equal lengths to the load.
- of sufficient ampacity (cable ampacity should not be exceeded).

6.0 UNPACKING AND HANDLING FOR INSTALLATION

6.1 General

Battery modules are shipped upright on pallets. All accessories for installation and use are supplied as optional prepackaged kits and are shipped on separate pallet(s) and/or in box(es). Cells may be packed in wooden boxes, which must be opened completely and carefully. The cells **must then be handled as described in the appropriate Installation Manual.**

DO NOT lift any cell by the terminal posts as this will void the warranty. When lifting large cells/units with crane, hoist or similar device, use lifting belt(s) and protective styrofoam shipping cover(s) provided (when applicable).

DO NOT attempt to remove the pressure relief valves or vent covers as this will void the warranty. Attempted removal may also damage the vent and prevent proper functioning of the battery.

6.2 Accessories

CHECK accessory package with Packing List/Bill of Material to ensure completeness. VERIFY QUANTITY OF ITEMS WITH THE *PACKING LIST*. DO NOT proceed with installation until all accessory parts are available.

Accessories are packed in a separate carton and may include, but are not limited to, the following:

TABLE 6.1		
ACCESSORIES		CHECK IF RECEIVED
Connector Hardware (in a plastic bag)	<ul style="list-style-type: none"> • Intercell Connectors • Bolts • Nuts • Washers 	
Lifting Straps		
Lifting Platform - Height adjustable lifting platform for supporting cells at module level.		
Base-beams		
Terminal Plate Kits		
Terminal Plate Connectors		
Cell Number Set		
Mounting Hardware		
Miscellaneous:	<ul style="list-style-type: none"> • Brackets • Specialty Items 	
Rack		
NO-OX-ID-Grease		
Rack Assembly Instructions		
Assembly Drawing		
Bill of Materials		
Installation Manual		

6.3 Recommended Installation Equipment and Supplies

Before working with the battery system, be sure that you have the proper protective clothing, safety equipment and insulated tools as specified in Section 2.0.

The following is a list of equipment typically recommended for installation of a PowerSafe™ VRLA Battery System.

TABLE 6.2	
EQUIPMENT RECOMMENDED	CHECK IF ON HAND
Forklift or Portable Lift Crane	
Chalk Line	
Torpedo Level (Plastic)	
Torque Wrench (10-200 in-lbs)	
Torque Wrench (50-100 ft-lbs)	
Floor Anchors (User-supplied per battery system and stress analysis)	
Floor Shims (User-supplied)	
3/8" Drive Ratchet Wrench with Minimum 3" Extension With 3/8" thru 11/16" and M6, M8, and M10 Sockets	
Box Wrenches (3/8" to 11/16" and M6, M8, and M10)	
Screwdrivers	
Wipes, Paper or Cloth	
Stiff-Bristle Nonmetallic Brush/Pad	
Tape Measure (Nonmetallic)	
Safety Equipment and Clothing	
Small Paintbrush	
Standard Allen Wrench Set	
NO-OX-ID Grease	



CAUTION

Be sure you have all the proper protective clothing and safety tools and equipment on hand before starting the installation.

7.0 INITIAL and/or FRESHENING CHARGE

Batteries lose some initial charge during shipment and storage. Depending on storage time, a battery may require a *freshening charge*. See Section 4.0 for battery storage times.

Constant voltage is the **ONLY** charging method allowed. Confirm that your charger bus is a constant voltage type. (Most modern chargers are the constant voltage type.)

1. Determine the maximum voltage that may be applied to the system equipment (or maximum charger voltage if load is not yet connected). Refer to the recommendations of the manufacturer/supplier of system equipment, connected to DC bus.
2. Divide the maximum total system voltage by the number of cells (not units) connected in series. This is the maximum volts per cell that may be used for the initial charge.
Do NOT exceed 2.35 volts per cell.

Table 7.1 lists recommended initial charge voltages per cell and charge time for the initial charge. Select the **HIGHEST** voltage the system allows for the initial charge without exceeding 2.35 volts per cell.

CELL VOLTS Initial Charge	TIME (Hours) Temp. 60°-90°F (16°-32°C)	TIME (Hours) Temp. 40°-59°F (5°-15°C)	TIME (Hours) Temp. < 39°F (<4°C)
2.27	60	120	240
2.30	48	96	192
2.32	24	48	96
2.35	12	24	48

3. Connect battery positive (+) terminal to charger bus positive (+) terminal.
4. Connect battery negative (-) terminal to charger bus negative (-) terminal.
5. Raise the voltage to the maximum value permitted by the equipment as shown in Table 7.1. Do NOT exceed 2.35 volts under any conditions.
6. When charging current has decreased and stabilized (i.e., no further reduction for three hours), charge for the hours shown in Table 7.1, or until the lowest cell voltage ceases to rise.



CAUTION

Monitor the battery temperature during the charge. If the cell/battery temperature exceeds 105°F (40°C) stop the charge immediately and allow the temperature to decrease below 90°F (32°C). Failure to follow this warning may result in severe overcharge and damage to the cell/battery.

8.0 OPERATION

8.1 General

The sealed design of the VRLA batteries makes it impossible to measure specific gravity as a state-of-charge indicator. The state-of-charge can be identified to some degree by the amount of charging current going to the battery exceeding 2.35 volts per cell.

8.1.1 Determining the State-of-Charge

The following method can be used to determine the state-of-charge of the battery.

1. Place the battery on charge/recharge following a discharge.

Read the ammeter.

The charging current will be a combination of the load current plus the current necessary to charge the battery.

2. The battery becomes fully charged when the current to the battery starts to decrease and stabilize.
3. When the current level remains constant for three consecutive hours, the state-of-charge is approximately 95 to 98%. Full charge can be assumed.

For most requirements, the battery is ready for use.

NOTE

Optional catalyst vents may be used on mSeries and DDM cells. A White paper discussion about the use of catalyst vents can be found on the EnerSys® website at www.enersys.com.

8.2 Float Operation

In this type of operation, the battery and the critical load circuits are continuously connected in parallel with a constant voltage charger. The charger should be capable of:

- charging the battery from the discharged condition while supplying the DC power to the connected DC load
- providing the required constant float voltage
- providing voltage for equalizing the battery

It is highly recommended that the battery be charged with a temperature compensated charger with adjustment as stated in Table 8.1. If a temperature compensated charger is not used, manual adjustments must be made according to Table 8.1.

TABLE 8.1		
AVERAGE AMBIENT TEMPERATURE		RECOMMENDED FLOAT VOLTAGE
°F	°C	VOLTS PER CELL
25	-4	2.33
35	2	2.33
45	7	2.32
55	13	2.30
65	18	2.28
77	25	2.25
85	29	2.23
95	35	2.21
105	41	2.19
115	46	2.17
125	52	2.17

Float voltage sustains the battery in a fully charged condition and makes it available to assume the emergency power requirements in the event of an AC power interruption or charger failure.

Constant voltage output charging equipment is recommended. This type of charger, properly adjusted to the recommended float voltages, and the following recommended surveillance procedures will assist in obtaining consistent serviceability and optimum life.

8.2.1 Float Charge Method

A float charge is given after the battery has been given its initial charge. To perform a float charge, follow the procedure below after the battery has been given its initial charge:

1. Determine that the VOLTS PER CELL nominal value is within the 2.23 to 2.27 range. This can be done by measuring the total battery string voltage and dividing by the number of cells in the string. Make sure the voltage does NOT exceed the maximum voltage for the connected load.
2. Adjust the charger to provide the recommended float voltage **at the battery terminals**. Do NOT use float voltages HIGHER or LOWER than those recommended. Otherwise reduced battery life or reduced capacity will result.
3. Check and record battery terminal voltage monthly for accurate calibration.
4. If the VOLTS PER CELL average voltage is above or below the range recommended in Procedure 1, adjust the charger to provide proper voltage as measured **at the battery terminals**.

When the **mSeries, DDm, DDS, DDV** and **SC**-type cells are new, expect to see variations in float voltage from cell to cell within a string. These cell voltages should be within ± 0.09 volts of the nominal setting). After one year in service, the mSeries, DDm, DDS and DDV-type cells will float within ± 0.05 volts of the nominal setting.

When the **DGX**-type cells are new, expect to see variations in float voltage from cell to cell within a string (within ± 0.13 volts of the nominal setting). After six months in service, the cells will float within ± 0.08 volts, and after one year, ± 0.06 volts of the nominal setting

8.3 Equalizing Charge

Under NORMAL conditions an equalizing charge is NOT required. An equalizing charge is a special charge given to a battery when nonuniformity in voltage has developed between cells. It is given to restore all cells to a fully charged condition.

Nonuniformity of cells may result from:

- low float voltage due to improper adjustment of the charger.
- a panel voltmeter that reads high, resulting in a low charger output voltage.
- selection of too low a float voltage.
- variations in cell temperatures in the series at a given time, due to environmental conditions or module arrangement. The maximum cell-to-cell temperature difference is 5°F (3°C). If cell temperature is the problem, review the location instructions in Section 5.0 to ensure proper location of the battery system.

An equalizing charge should be given when:

- the float voltage of any cell is less than 2.17 volts per cell.
- the float voltage range after six months is OUTSIDE the ± 0.08 volts of the nominal setting.

Do **NOT** equalize **DDS**, **DDm**, **DDV**, **mSeries** and **SC**-type cells if they are within the following voltage limits:

New ± 0.09 volts of the nominal value, as determined in Section 8.2.1, Procedure No.1.

After one year ± 0.05 volts of the nominal value, as determined in Section 8.2.1, Procedure No.1.

Do **NOT** equalize **DGX**-type cells if they are within the following voltage limits:

New ± 0.13 volts of the nominal value, as determined in Section 8.2.1, Procedure No.1.

After six months ± 0.08 volts of the nominal value, as determined in Section 8.2.1, Procedure No.1

After one year ± 0.06 volts of the nominal value, as determined in Section 8.2.1, Procedure No.1

8.3.1 Equalizing Charge Method

Constant voltage charging is the method for giving an equalizing charge. To perform an equalizing charge, follow the procedure below:

1. Determine the maximum voltage that may be applied to the system equipment.
2. Divide this voltage by the number of cells connected in a series.
This is the **MAXIMUM VOLTS PER CELL** to be used for the equalizing charge.
This number should **NOT** exceed **2.35 VOLTS PER CELL** average.
3. Use Table 8.2 to determine the equalize charge time.

The times listed are the number of hours to charge the battery system **AFTER** the charge current has been stabilized for three hours.

Stabilization occurs when the current level remains constant for three hours.

TABLE 8.2		
CELL VOLTS	TIME (hours) AFTER CURRENT STABILIZATION (3 hours without change) AT AMBIENT TEMPERATURES FROM 70-90°F (21-32°C)	TIME (hours) AFTER CURRENT STABILIZATION (3 hours without change) AT AMBIENT TEMPERATURES FROM 55-69°F (13-20°C)
2.32	24	48
2.35	12	24



CAUTION

During charge, if the cell/battery temperature exceeds 105°F (40°C) stop the charge immediately and allow the temperature to decrease below 90°F (32°C). Failure to follow this warning may result in severe overcharge and damage to the cell/battery.

9.0 BATTERY TAPS

Connections made to a battery for tapping a certain group of cells to provide a voltage other than the total battery voltage is NOT recommended and can **void the warranty**. Tapping results in an imbalance of the system during charging and discharging, causing unsatisfactory operation.

10.0 PILOT CELL

One cell in a battery is usually selected as a pilot cell. It becomes an indicator of the general condition of the entire battery with regard to voltage, gravity, and temperature. Designate as the pilot cell the cell with the lowest cell voltage in the series string following the initial charge. Pilot cell readings serve as an interim indicator between regularly scheduled voltage and gravity readings of the complete battery. The temperature sensor should be connected to the negative post of the pilot cell.

Read and record the pilot cell voltage on a monthly basis between regularly scheduled individual cell readings.

11.0 MAINTENANCE

Batteries lose some initial charge during shipment and storage. Depending on storage time, a battery may require a freshening charge. See Section 4.0 for battery storage times.

11.1 Battery Cleaning

Observe the battery for cleanliness at regular intervals. Keep cell terminals and connectors free of corrosion. Terminal corrosion could adversely affect the performance of the battery, and it could present a safety hazard.

11.1.1 Standard Cleaning

To perform a standard cleaning of the battery, follow the procedures below:

1. Disconnect the battery.
2. Wipe off any accumulation of dust on the cell covers with a cloth dampened in clean water.



WARNING

Do NOT use any type of oil, solvent, detergent, petroleum-based solvent or ammonia solution to clean the jars or covers. These materials will have an adverse affect and cause permanent damage to the battery jar and cover and will void the warranty.

11.1.2 Battery Taps

To clean mild corrosion from the battery:

1. Disconnect the battery.
2. Remove corrosion by wiping with a cloth dampened with bicarbonate of soda solution [mix 1 gallon (4l) of water with 1 lb. (500g) of bicarbonate of soda]. Follow with a cloth dampened with clear water.
3. Dry with a clean cloth.
4. With a small paintbrush, apply a light coat of heated NO-OX-ID grease to the entire bolted connection.

NOTE

If optional catalyst vents are used, no cleaner of any kind other than water may be used on the vent caps. Use of cleaners other than water may reduce or completely remove the effectiveness of the vents.

11.1.3 Corrosion Cleaning

If routine cleaning of the bolted connections has been neglected, heavy post corrosion may occur. This will require a major cell post cleaning job requiring the unbolting and removing of the connectors. The performance of the battery under load could be adversely affected, and this condition could present a safety hazard.

To perform the heavy corrosion cleaning, follow the procedure below.

1. Unbolt and remove connectors.
2. Apply a solution of bicarbonate of soda and water to the cell posts and connectors to neutralize the corrosion (as described in Section 11.1.2).
3. Clean the contact surfaces by rubbing the surface of post or terminal and lead-plated contact surfaces with a stiff-bristle nonmetallic brush/pad. Lightly brush tin plated connectors. Exercise care so you **do NOT remove the plating on the connectors, terminal plates or lugs, exposing copper.**
4. Bolt all intercell connectors.

Install as follows:

- | | |
|------------------------|----------------|
| a) Intercell Connector | c) Lock Washer |
| b) Flat Washer | d) Bolt |



WARNING

Stamped flat washers may have one sharp edge. Install the washer with the sharp edge away from the lead-plated copper intercell connector to avoid damaging the lead plating.

REFER TO APPROPRIATE INSTALLATION MANUAL FOR ADDITIONAL INFORMATION.

5. Install all connections finger-tight to allow for some adjustment of position.
6. After all connections are completed, torque to original installation specifications.
7. Recoat the contact surfaces with a thin application of the NO-OX-ID grease, heated to a liquid form and applied with a small paintbrush.

11.2 TEST PROCEDURES

11.2.1 Procedure for Battery Capacity Tests

Use the following test procedure or use the test procedure described in IEEE std. 1188.

An equalizing charge, as described in Section 8.3, must have been given within the last 7 days. (Battery should be returned to float for 7 days before the test.)

1. Make sure all battery connections are clean, tight and free of corrosion.
2. While the battery is on float read and record voltage of each cell, temperature of at least every tenth cell and battery terminal float voltage.
3. Disconnect the battery charger.
4. Select the discharge rate based upon the critical load and time period. The test discharge current is equal to the rated discharge current divided by the K Factor (see Table 11.1) for the initial battery temperature.
5. With the variable load bank having an ammeter in series and a voltmeter across the battery terminals, connect the load, simultaneously starting the timing device. Maintain the correct current while periodically reading and recording total battery voltage. When the minimum total voltage has been reached, it is desirable to read and record each cell voltage including an intercell connector.
6. Observe the battery for intercell connector heating.
7. Calculate the capacity using the following formula:

$$\% \text{ Capacity at } 77^{\circ}\text{F (} 25^{\circ}\text{C)} = \frac{T_a}{T_s} \times 100$$

Where T_a = test discharge time to specified voltage.

Where T_s = rated discharge time to specified voltage.

8. Recharge the battery, preferably using an equalizing charge (Section 8.3) to minimize the recharge time.

K TABLE TABLE 11.1		
Initial Temperature		Factor K
(°C)	(°F)	
16.7	62	1.098
17.2	63	1.092
17.8	64	1.086
18.3	65	1.080
18.9	66	1.072
19.4	67	1.064
20.0	68	1.056
20.6	69	1.048
21.1	70	1.040
21.7	71	1.034
22.2	72	1.029
22.8	73	1.023
23.4	74	1.017
23.9	75	1.011
24.5	76	1.006
25.0	77	1.000
25.6	78	0.994
26.1	79	0.987
26.7	80	0.980
27.2	81	0.976
27.8	82	0.972
28.3	83	0.968
28.9	84	0.964
29.4	85	0.960
30.0	86	0.956
30.6	87	0.952
31.1	88	0.948
31.6	89	0.944
32.2	90	0.940
32.8	91	0.938
33.4	92	0.936

11.3 Maintenance Records

A complete recorded history of the battery operation is essential for obtaining satisfactory performance. Good records will show when corrective action may be required to eliminate possible charging, maintenance or environmental problems.

Should you have ANY questions concerning how to perform the required maintenance, contact your nearest EnerSys® sales/service representative or call the corporate office number listed on the back of this manual and ask for EnerSys Reserve Power Service.

Accumulate and permanently record the following data for review by supervisory personnel so that any necessary remedial action may be taken:

1. Upon completion of the initial charge and with the battery on float charge at the proper voltage for one (1) week, read and record the following:
 - individual cell or unit voltages (volts)
 - cell-to-cell connection resistance (ohms)
 - terminal connection resistance (ohms)
 - ambient temperature in the immediate battery environment (°F or °C)

NOTE: Some internal failure modes of cell types DDm, mSeries, DDS, DDV, and DGX cannot be detected by cell or unit voltage measurements. IEEE-1188,1996 recommends taking an internal ohmic measurement of the cell/unit at quarterly intervals. These internal ohmic measurements, when compared with baseline value or the average value, may indicate the beginning of a problem inside the cell. Then corrective actions can be taken to avoid a battery system failure. EnerSys® recommends that you follow IEEE-1188 standards for internal ohmic measurements for VRLA cell types.

2. Every 12 months, read and record the following:
 - individual cell or unit voltages (volts)
 - cell-to-cell connection resistance (ohms)
 - terminal connection resistance (ohms)
 - ambient temperature in the immediate battery environment (°F or °C)

Any connection resistance that exceeds the base value by more than 20% should be corrected by the procedures of Section 11.

3. If corrosion is present in the connections, clean according to Section 11.1.
4. Whenever the battery is given an equalizing charge, an additional set of readings should be taken and recorded.

THE ABOVE FREQUENCY OF RECORD TAKING IS THE ABSOLUTE MINIMUM TO PROTECT THE WARRANTY. This data will be required for any warranty claim made on the battery. For system protection and to suit local conditions/requirements, more frequent readings (quarterly) are desirable.

Sample record charts are provided on the following pages. Make a copy of the chart to use for your permanent records.

BATTERY MAINTENANCE REPORT - DDM, DDS, DDV, DGX, mSeries, and SC

COMPANY _____ DATE ____ / ____ / ____ PAGE 1 of ____
 ADDRESS _____ BATTERY LOCATION and/or NUMBER _____
 No. of CELLS _____ TYPE _____ DATE NEW ____ / ____ / ____ SERIAL NO. _____
 SYSTEM VOLTAGE _____ TEMPERATURE _____ CHARGER VOLTAGE _____ CHARGER CURRENT _____

Cell to Cell Resistance	Cell No.	Volts	Terminal Connection Resistance	Cell to Cell Resistance	Cell No.	Volts	Terminal Connection Resistance	Cell to Cell Resistance	Cell No.	Volts	Terminal Connection Resistance	Cell to Cell Resistance	Cell No.	Volts	Terminal Connection Resistance
—	1			—	31			—	61			—	91		
	2				32				62				92		
	3				33				63				93		
	4				34				64				94		
	5				35				65				95		
	6				36				66				96		
	7				37				67				97		
	8				38				68				98		
	9				39				69				99		
	10				40				70				100		
	11				41				71				101		
	12				42				72				102		
	13				43				73				103		
	14				44				74				104		
	15				45				75				105		
	16				46				76				106		
	17				47				77				107		
	18				48				78				108		
	19				49				79				109		
	20				50				80				110		
	21				51				81				111		
	22				52				82				112		
	23				53				83				113		
	24				54				84				114		
	25				55				85				115		
	26				56				86				116		
	27				57				87				117		
	28				58				88				118		
	29				59				89				119		
	30				60			—	90			—	120		

BATTERY MAINTENANCE REPORT - DDM, DDS, DDV, DGX, mSeries, and SC

COMPANY _____

DATE ____ / ____ / ____

PAGE 2 of _____

Cell to Cell Resistance	Cell No.	Volts	Terminal Connection Resistance	Cell to Cell Resistance	Cell No.	Volts	Terminal Connection Resistance	Cell to Cell Resistance	Cell No.	Volts	Terminal Connection Resistance	Cell to Cell Resistance	Cell No.	Volts	Terminal Connection Resistance
---	121			---	151			---	181			---	211		
	122				152				182				212		
	123				153				183				213		
	124				154				184				214		
	125				155				185				215		
	126				156				186				216		
	127				157				187				217		
	128				158				188				218		
	129				159				189				219		
	130				160				190				220		
	131				161				191				221		
	132				162				192				222		
	133				163				193				223		
	134				164				194				224		
	135				165				195				225		
	136				166				196				226		
	137				167				197				227		
	138				168				198				228		
	139				169				199				229		
	140				170				200				230		
	141				171				201				231		
	142				172				202				232		
	143				173				203				233		
	144				174				204				234		
	145				175				205				235		
	146				176				206				236		
	147				177				207				237		
	148				178				208				238		
	149				179				209				239		
	150				180				210				240		

ADDITIONAL COMMENTS: _____

12.0 TEMPORARY NON-USE (EXTENDED OUTAGE)

12.1 Installed/Out-of-Service System

If an INSTALLED battery is expected to STAND IDLE longer than the storage period recommended for the storage temperature (see Table 4.1 on page 9), treat as follows:

1. Before taking the battery out of service, give it an equalizing charge according to Section 8.3.1.
2. After the charge, open the connections at the battery terminals to remove load from the battery.
3. Throughout the extended non-use period, give the battery an equalizing charge before the end of the recommended storage intervals noted in Table 4.1. Disconnect the battery from the charger between equalizing charges.

12.2 Return to Service

To return the battery to normal service:

1. Reconnect the battery, the load and charger.
2. Give the battery an equalizing charge as described in Section 8.3.1.
3. Return the battery to float operation.

NOTES

PRECAUTIONS*

1. Do not bring any heat or flame source near battery.
2. Do not remove pressure relief valves.



DO NOT PUSH ON CENTER
TO POSITION BATTERY

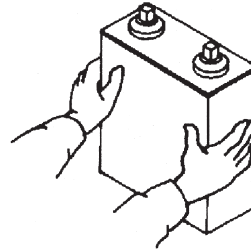

USE EDGE OF MODULE
WHEN POSITIONING BATTERY

3. Do not lift any cells by the terminal posts.
4. Do not tamper with seal nuts on the cell post.
5. Do not remove lead coating from post or connectors and expose any bare copper.
6. Do not allow cell temperature to exceed 105°F during charging.
7. Do not clean cell with anything other than water/bicarbonate of soda.
8. Do not over torque connections.
9. Do not store VRLA type batteries for over six months without charge, at normal temperatures.

* These are only a few of the precautions. Please read all accompanying literature thoroughly for specific safety and installation information



When ordering new batteries, also remember to properly recycle your old lead batteries. Federal and state regulations require lead-acid batteries be recycled. The EnerSys® nationwide service organization can arrange pickup, transportation to and recycling at any one of our company affiliated smelters. Call 1-800-972-7372 for more information.



Please visit www.enersys.com for literature updates.



www.enersys.com

EnerSys
P.O. Box 14145
Reading, PA 19612-4145
USA
Tel: +1-610-208-1991
+1-800-538-3627

EnerSys EMEA
Brussels, Belgium
Tel: +32 (0)2 247 94 47
EnerSys Asia
Guangdong, China
Tel: +86 755 2689 3639

Represented by:

© 2008 EnerSys. All rights reserved.
Trademarks and logos are the property of
EnerSys and its affiliates unless otherwise noted.