

Operation Manual

Pika Harbor Smart Battery

Harbor Flex / Harbor Plus

Part of the Pika Energy Island™





Harbor Smart Battery

Serial Number:

RCP Number:

We are committed to quality and constant improvement. All specifications and descriptions contained in this document are verified to be accurate at the time of printing. However, we reserve the right to make modifications at any time that may result in a change of specification without notice in our pursuit of quality. If you find any inconsistencies or errors in this document, please notify us at sales@pika-energy.com

Check the resources tab at www.pika-energy.com for the latest specifications and manuals.

© 10/24/18 Pika Energy, Inc. All rights reserved.

All information in this document is subject to copyright and other intellectual property rights of Pika Energy, Inc. This material may not be modified, reproduced or copied, in whole or in part, without the prior written permission of Pika Energy, Inc. and its licensors. Additional information is available upon request.

Table of Contents

Section 1: Introduction	4
About this manual	4
Symbols used in this Manual	4
About the Harbor Smart Battery	5
Section 2: Safety instructions	7
General Warnings	7
Safety Shutdown	8
Battery Module Safety	9
Section 3: Operation and Controls	10
Communication	10
System Operational Modes	10
Islanding	10
Battery State of Charge (SOC) Setpoints	11
User Interface	12
Section 4: Powering the Nanogrid Without Utility Power	14
Islanding Mode	14
Power Search	14
Blackstart and Manual Enable	16
Section 5: Service and Maintenance	17
Annual Inspection and Maintenance	17
Service	18
End of Life	18
Section 6: Technical Reference	19
Section 7: Product Specifications	21
Section 8: Notes	22

Section 1: Introduction

About this manual

This Operation Manual provides instructions for the use, operation, and maintenance of the Pika Harbor Series of smart batteries for simple, reliable energy storage with optional solar charging. The Harbor Smart Battery is designed to house compatible lithium ion battery modules, and connects directly to the Pika Islanding Inverter™ and other REbus™- compatible components of the Pika Energy Island™ system from Pika Energy.

This Operation Manual includes full details on the use, operation, and maintenance of Harbor. The companion document to this Operation Manual is the Harbor Installation Manual. Please reference the Installation Manual for complete information on installing, wiring, and commissioning the Harbor smart battery.

Symbols used in this Manual



WARNING: This indicates a fact or feature very important for the safety of the user to prevent injury or death and/or which can cause serious hardware damage if not applied appropriately.



CAUTION: Presents information to prevent damage to this product.



EARTH GROUND SYMBOL

About the Harbor Smart Battery

The Harbor Smart Battery is an easy-to-install energy storage device for efficient DC-coupled performance. As a storage component of the Pika Energy Island, Harbor Smart Battery models can be used for grid-connected solar applications such as self-supply, rate arbitrage and clean backup power. Both the Harbor Flex™ and Harbor Plus™ models are designed to work seamlessly with Pika Energy’s S2500 Series PV Link optimizers, and X7600 and X11400 Series Islanding Inverters to form the Pika Energy Island system for grid-tie solar-plus-storage.

All Pika Energy products use the REbus™ 380VDC nanogrid to connect energy sources, storage, loads and the grid. The REbus nanogrid automates the flow of power to enable plug-and-play setup and operation of Pika Energy equipment. For more information about REbus, visit pika-energy.com.

In the diagram below, a REbus compatible Pika Islanding Inverter is directly connected to PV Link optimizers and high voltage energy storage on the DC (REbus) line, shown to the the left of the inverter. To the right of the inverter are AC lines: 240VAC or 208VAC for grid and home loads, and critical load support up to 50A.

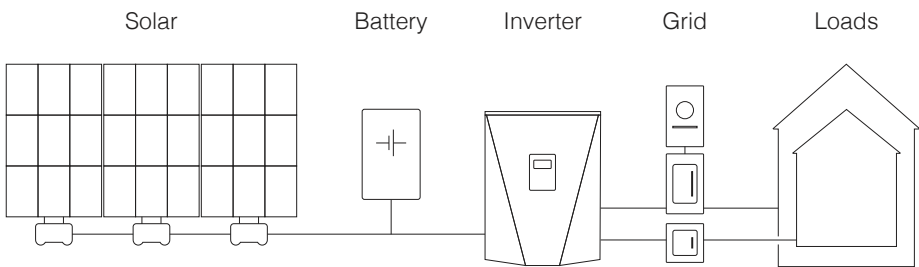

Fig 1. Example Energy Island



Section 2: Safety instructions

IMPORTANT SAFETY INSTRUCTIONS. SAVE THESE INSTRUCTIONS!

General Warnings



SHOCK RISK: HIGH VOLTAGE ELECTRICITY

WARNING: To reduce the risk of injury, read all instructions and caution markings before installing Harbor. Consult installation documentation for all other REbus devices on the system.

WARNING: Harbor must be installed by trained and qualified technicians, and in accordance with all instructions.

WARNING: Electrical installation in the United States shall be done in accordance with all local electrical codes and/or the National Electrical Code (NEC), ANSI/NFPA 70.

WARNING: Electrical installation in Canada shall be done in accordance with all local electrical codes and/or the Canadian Electrical Code.

WARNING: Connecting the Pika Energy Island to the electric utility grid must only be done after receiving prior approval from the utility company and installation completed only by qualified personnel/licensed electrician(s).

WARNING: This equipment is NOT intended for use with life support equipment or other medical equipment or devices.

WARNING: Protection against lightning surges in accordance with local electric codes are the responsibility of the installer.

WARNING: Connect only to REbus-compatible devices. Never connect to ANY other power source, including raw PV output, AC power, or any non-REBUS compatible battery.

WARNING: POWER SEARCH. TURN BATTERY DISCONNECT "OFF" AND DE-ENERGIZE REBUS BEFORE TOUCHING TERMINALS.

Safety Shutdown

The Pika Energy Island system can signal to connected devices on REbus to shut down and limit output voltage to a safe level. The red Safety Shutdown button on the front of the Pika Islanding Inverter activates a Safety Shutdown. An external shutdown button may also be installed, given appropriate labeling. See the section titled “Safety Shutdown” in the Islanding Inverter Installation manual.

To enter a Safety Shutdown, press and hold the red button on the front of the inverter. The Safety Shutdown LED will illuminate and the LCD screen will indicate a Safety Shutdown has been initiated.

In a system configured to provide backup power, the DC bus will remain energized on loss of AC grid power. Upon entering a Safety Shutdown, a shutdown signal will be transmitted to all devices connected to REbus. In Safety Shutdown, the Islanding Inverter will disconnect from the grid, stop sourcing power to REbus, and immediately disable all sources on REbus by sending a global shutdown signal. All PV Link optimizers will disconnect their output. The Safety Shutdown LED will be illuminated to show that the inverter has entered a Safety Shutdown. DC bus voltage will be displayed on the inverter screen.



WARNING: BEFORE PERFORMING SERVICE, ALWAYS INITIATE A SYSTEM-WIDE SAFETY SHUTDOWN AND TURN THE FRONT PANEL BATTERY DISCONNECT SWITCH TO “OFF” ON ALL CONNECTED SMART BATTERIES. UNLESS THE BATTERY SWITCH IS “OFF”, THE BATTERY MAY PERFORM A POWER SEARCH AT ANY TIME WHICH WILL CREATE DANGEROUS VOLTAGE AT THE REBUS TERMINALS.

Battery Module Safety

Harbor is designed to be used with Panasonic DCB-105 lithium ion battery modules. Do not attempt to connect batteries of any other make or model to your Harbor Smart Battery, including any other lithium ion battery, or any other type of battery.



WARNING: Use ONLY Panasonic DCB-105 lithium ion battery modules. DO NOT CONNECT ANY OTHER BATTERY MODULES. DOING SO WILL VOID THE WARRANTY AND MAY DAMAGE THE HARBOR SMART BATTERY.

Refer to the battery manufacturer's documentation for warnings, hazards, and safe handling instructions for your battery modules.



WARNING: DO NOT ATTEMPT TO FIGHT A FIRE YOURSELF. EVACUATE THE BUILDING AND CONTACT EMERGENCY SERVICES. Inform the dispatcher that there are lithium-ion batteries in the building.

Keep a carbon dioxide or dry chemical fire extinguisher near the battery location for use in emergency by trained personnel only.

Emergency personnel: Refer to the manufacturer's instructions and/or Safety Data Sheet for complete information on fire fighting.

Section 3: Operation and Controls

Communication

All communication between REbus devices takes place over the REbus conductors using Power Line Carrier (PLC) communication. No additional communication wiring or equipment is required for communication between a Harbor Smart Battery and the inverter, PV array, and/or other REbus enabled smart batteries.

SunSpec Communications

The Harbor smart battery is capable of remote monitoring and control via a SunSpec interface. Contact Pika Energy for more information on how to interact with Harbor via SunSpec.

System Operational Modes

The Pika Energy Island system has several operational modes available for various installation configurations, markets, and applications. The Operational Mode is selected through the front control panel of the Islanding Inverter. The Islanding Inverter prioritizes the distribution of power differently based on the selected operational mode.

Refer to the Pika Islanding Inverter Installation and Operation Manuals for complete instructions on configuring your entire system for each Operational Mode, including installing the inverter, CTs, and transfer switches.

Islanding

The inverter must have Islanding enabled in order for the system to provide backup power during grid outages. Ensure the inverter "NolSlanding" setpoint is set to "0".

1. Navigate to the Inverter device page.
2. Press the center button to bring up the menu and select "Mod. Settings".
3. Set "NolSlanding" to "0".
4. The inverter may now provide backup power during grid outages.

Battery State of Charge (SOC) Setpoints

There are four user-adjustable setpoints related to the battery state of charge (SOC). These setpoints allow you to customize the behavior of your smart battery under different conditions. The SOC is expressed as a percent (0% to 100%).

Setpoint	Behavior
Max absolute	When the battery SOC is above this point, Harbor will not charge from any source. Default value is 100%.
Max arbitrage	When the battery SOC is above this point, Harbor is the lowest priority destination for power. Harbor will charge only from PV power and only if all other higher priority loads are satisfied. Default value is 100%.
Min arbitrage	<p>When the battery SOC is below this point, Harbor is the lowest priority source of power on REbus. Harbor will discharge only if there is no other source of power available. This will prevent the system from operating in Self Supply until the battery SOC increases. If the grid goes out and the system begins Islanding, then the battery will supply backup power normally. Default value is 50%.</p> <p>If you lower this setpoint, you will have more battery capacity available for Self Supply and other non-backup uses, but your guaranteed Islanding reserve will be smaller in the event of an outage. If you raise this setpoint, you will have less capacity available for Self Supply and related modes, but you can be sure of having more energy in your Islanding reserve in case of a grid outage.</p>
Min absolute	<p>When the battery SOC is below this point, Harbor shuts off and will not discharge further. If the grid is present, then Harbor will charge as soon as power is available on REbus. If the grid is not present and the system is Islanding, then Harbor goes to sleep and performs a Power Search every 30 minutes. (See below for more information on Power Search.)</p> <p>The battery must charge to at least 5% above this setpoint before it will begin exporting power.</p> <p>If you lower this setpoint, the system can provide more energy before it goes to sleep, potentially keeping the lights on for a longer time, but the Power Search reserve will be smaller. If you raise this setpoint, the system may shut down sooner during an outage, but the Power Search reserve will be larger.</p>

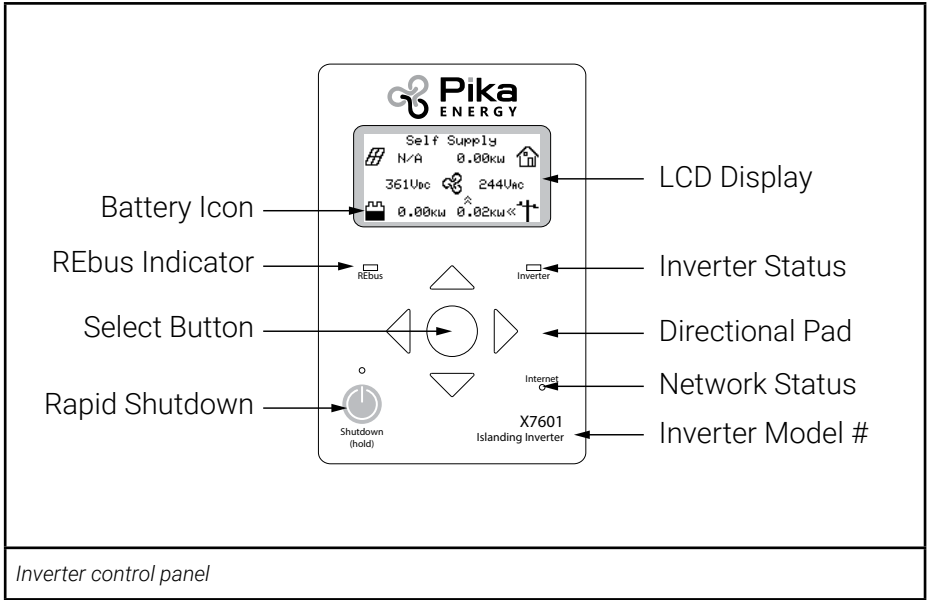

User Interface

Inverter Control Panel

The Harbor is controlled through the front panel of your Islanding Inverter. Use the inverter to enable or disable your smart battery, and to set the Operational Mode for your Energy Island system.

Battery Disconnect Switch

There is a toggle switch on the front of the Harbor enclosure at the top left labeled “On” and “Off”. This switch controls a set of internal relays which disconnect the battery string from the battery monitoring system (BMS) electronics. Always initiate a Safety Shutdown from the inverter and turn this switch to “Off” before servicing any part of the Pika Energy Island to prevent Harbor from energizing the REbus Nanogrid. This switch may be locked in the “Off” position.

If the system will be powered down and left inactive for a long period of time, you may wish to toggle the switch to the “Off” position to prevent discharge of the battery modules over time.

Safety Shutdown Button

Before servicing any REbus equipment, always initiate a safety shutdown using the inverter controls. If a lockable external Safety Shutdown switch is installed, then you may lock this switch in the "Off" position.

LED

LED state	Interpretation (strobe interval)
Green, 3 sec solid at powerup	Enabled, operation starting
Red, 3 sec solid at powerup	Disabled
Red/green, alternating	Initializing, connecting battery and REbus, system energizing
Green, solid	Enabled, charging
Green, strobe	Enabled, standby (3 secs)
Green, flashing	Enabled, discharging
Yellow, solid	Waiting
Red, strobe	Disabled (3 secs) / asleep (8 secs)
Red, flashing	Error state

Section 4: Powering the Nanogrid Without Utility Power

Islanding Mode

In the event of a grid outage, the Energy Island enters Islanding Mode: the Islanding Inverter disconnects from the utility grid and powers the building from the REbus Nanogrid.

In a typical solar-plus-storage configuration, this means that all REbus-connected smart batteries (including Harbor) will work together with the PV Links to supply power to REbus. The Inverter will pull power off of REbus to provide AC power to the building.

Power Search

Harbor includes a Power Search feature. Power Search allows the system to discover sources of power even after the battery has been almost fully discharged.

Sleep

While the system is in Islanding Mode, Harbor may charge from PV power if there is plenty of sunlight and not much load from the building. However, as Harbor provides power to the building loads, its State of Charge (SOC) will go down. Once the SOC reaches the Min Absolute setpoint (described above), Harbor will enter a sleep state, the Islanding Inverter will shut down, and the building will lose power.

Power Search

While it is sleeping, the Harbor battery spends most of its time in a very low power state. Every 30 minutes, Harbor will perform a Power Search.

During a Power Search, Harbor wakes up, energizes the REbus Nanogrid to 380VDC, and scans for potential sources of power. If there is another source of power available, such as PV Link, then Harbor will begin charging. Once Harbor's SOC is 10% above the Min Absolute setpoint, it will supply power to the rest of the Nanogrid, allowing the Inverter to operate in Islanding Mode.

However, if the Power Search does not discover any other sources of power, then Harbor will return to sleep to conserve energy. The Power Search will maintain 380VDC on REbus for 60 seconds before Harbor returns to sleep.

Harbor can only perform a Power Search a certain number of times before it runs out of energy completely; the number of searches available is dependent on the value of the Min Absolute setpoint. Once Harbor depletes its Power Search reserve, it will not energize the REbus Nanogrid on its own. Another source of power is necessary to energize REbus and charge the battery.



WARNING: DURING A POWER SEARCH, HARBOR CREATES DANGEROUS VOLTAGE AT THE REBUS TERMINALS. To prevent Power Search, always turn the Harbor battery disconnect switch to “OFF” before performing service.

To prevent Harbor from performing a Power Search, turn the switch on the front cover of Harbor to the “Off” position.

Setpoint	Description	Default	Units
Power Search Interval	Length of time between Power Searches	30	min
Power Search Length	Length of time Power Search keeps REbus energized	60	s

Blackstart and Manual Enable

Harbor includes Blackstart capability. Blackstart allows Harbor to power up a system that is powered down and has no other sources of power available.

If Harbor is disabled, perform a Manual Enable as part of the Blackstart process. Manual Enable allows you to enable Harbor without powering on the inverter. Once enabled, Harbor can Blackstart the system.

Performing a Blackstart

To Blackstart, turn the switch to the ON position. If Harbor is enabled and the battery has sufficient charge, the front panel LED will light green.

After initialization is complete, then Harbor will automatically energize REbus and begin supporting REbus and AC loads, and charging from other sources if available (such as PV Link).

Performing a Manual Enable

If the front panel LED lights red when you turn on the Battery Disconnect switch, this means Harbor is disabled. You must perform a Manual Enable in order to Blackstart the system. Harbor cannot energize the REbus nanogrid until it is enabled using this sequence.

To perform a Manual Enable:

1. Turn the power switch to ON.
2. If the unit is disabled, the front LED will light red for 3 seconds.
3. While the LED is still lighted red, turn the switch back to the OFF position.
4. Perform steps 1-3 three times in total.
5. Turn the switch ON for a fourth time. Harbor is now enabled. If the battery has sufficient charge, then the front panel LED will light green to indicate that the battery is enabled and the system will Blackstart and resume normal operation.

Note: If Harbor does not have sufficient charge, then it cannot be used to Blackstart the system.

To avoid the need for a Manual Enable, always keep Harbor enabled, connected to REbus, and with the front power switch in the "ON" position.

Section 5: Service and Maintenance

Annual Inspection and Maintenance



WARNING: NO USER SERVICEABLE PARTS. Do not remove the front cover of your Harbor. Contact a qualified technician to service your unit.

Once per year, inspect the unit and its surroundings. Do not allow leaves, dust, pet hair, or other debris to accumulate near or under the Harbor. Ensure that the bottom intake vent and front exhaust vent are clear at all times.

Filter

Remove and inspect the bottom intake filter. Clean the filter with a vacuum cleaner, compressed air, or water. To remove the filter, push the filter straight towards the wall to compress the retention springs. Then pull the front edge down and slide the filter out. To re-install the filter, reverse the sequence. Allow the filter to dry before reinstalling.

If the air filter is damaged, contact Pika Energy for a replacement filter.

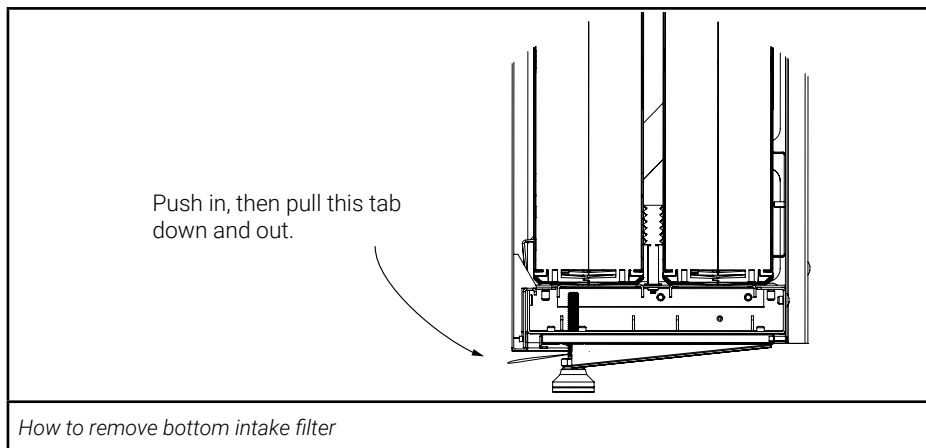

Service



WARNING: NO USER SERVICEABLE PARTS. Do not remove the front cover of your Harbor. Contact a qualified technician to service your unit.

WARNING: DURING A POWER SEARCH, HARBOR CREATES DANGEROUS VOLTAGE AT THE REBUS TERMINALS. To prevent Power Search, always turn the Harbor front panel switch to "OFF" before performing service.

WARNING: DISCONNECT ALL POWER SOURCES BEFORE SERVICING. Disconnect Harbor from DC sources and turn the front panel Battery Disconnect switch to "OFF" before opening the cover. Verify that voltage at the REbus terminals is at a safe level before proceeding.

If you are experiencing a problem with your Harbor smart battery, contact a qualified installer or technician for appropriate service. Qualified persons may refer to the Harbor Installation Manual for information on replacing the internal fuses and other troubleshooting.

End of Life

Refer to the Harbor Installation Manual for decommissioning/recycling procedure.

Section 6: Technical Reference

Replaceable fuses are as follows:

Fuse	Manufacturer/Part number	Ratings
Main battery string fuses	Ferraz A60Q40-2	40A, 600Vdc
Main battery string fuses (alternate)	Ferraz A60Q35-2	35A, 600V
Main battery string fuses (alternate)	Cooper Bussmann / Eaton KTK-40	40A, 600Vdc
Blackstart Battery Fuse	Littelfuse 0235005 HXP	5A, 125Vac

Technical Support Information

Support department hours: 9AM to 5PM Eastern Standard Time Zone, Monday – Friday
(excluding holidays)

Phone: (207) 808-0362

Email: support@pika-energy.com

Section 7: Product Specifications

Specification	Harbor Plus	Harbor Flex	Units	Notes
Usable capacity	17.1	11.4	kWh	Expandable up to 60kW with up to four units per inverter
Power (Continuous)	6.7	4.5	kW	-
Power (Surge)	10	6.7	kW	-
Battery Modules	6	4	-	Lithium ion (NMC): Panasonic DCB-105
Weight	411 (186)	311 (141)	lb (kg)	-
DC Voltage (per module)		52	Vdc	-
DC Current (Continuous)		24	A	-
Round Trip Efficiency		>90	%	-
Recommended Operating Temperature		13-30 (55-86)	C (F)	-
Acceptable Operating Temperature		0-50 (32-122)	C (F)	-
Dimensions	68.375 (1737) x 22 (558) x 9.87 (251)		in (mm)	-
Weight (Battery Module)		55 (25)	lb (kg)	-
Communication Protocol	REbus DC Nanogrid		-	Powerline carrier
Compliance	UL 9540		-	-
Warranty		10	years	-

Section 8: Notes

Use the following pages to record notes about your system or to document phone calls with our service department, available M-F 9AM-5PM ET at 207-808-0362.





www.pika-energy.com

35 Bradley Drive #1
Westbrook Maine
04092