

3.8
kWh

PHI 3.8-M™ Battery



BRIGGS & STRATTON



The **PHI 3.8-M** Battery utilizes advanced Lithium Ferro Phosphate (LFP) chemistry that eliminates cobalt which reduces the risk of thermal runaway, fire propagation, operating temperature constraints, and toxic coolants. When combined with our integrated high-performance Battery Management System (BMS), accessible 80A DC breaker On/Off switch and overcurrent protection (OCPD), the PHI 3.8-M Battery delivers safer, highly efficient and cost-effective service over the life of both residential and commercial installations, on or off-grid. Compatible with all industry standard inverter charge controllers, the PHI 3.8-M Battery supports balance-of-system equipment and optimizes any power generation source - solar, wind, grid, generator - with scalable, on-demand energy storage solutions for critical back-up and daily savings on electricity bills.

FEATURES



Scalable for any energy need

Virtually unlimited scalability to allow for longer-duration storage.



Pair with leading inverters

Ready to be integrated into industry leading inverters for ease of installation.



Lithium Ferro Phosphate (LFP) Chemistry

Peace of mind that the elimination of cobalt reduces the risk of thermal runaway, fire propagation, operating temperature constraints, and toxic coolants.



Leading safety-tested battery

Ideal for lead acid battery replacement.

48V Battery Voltage VS. Discharged Capacity

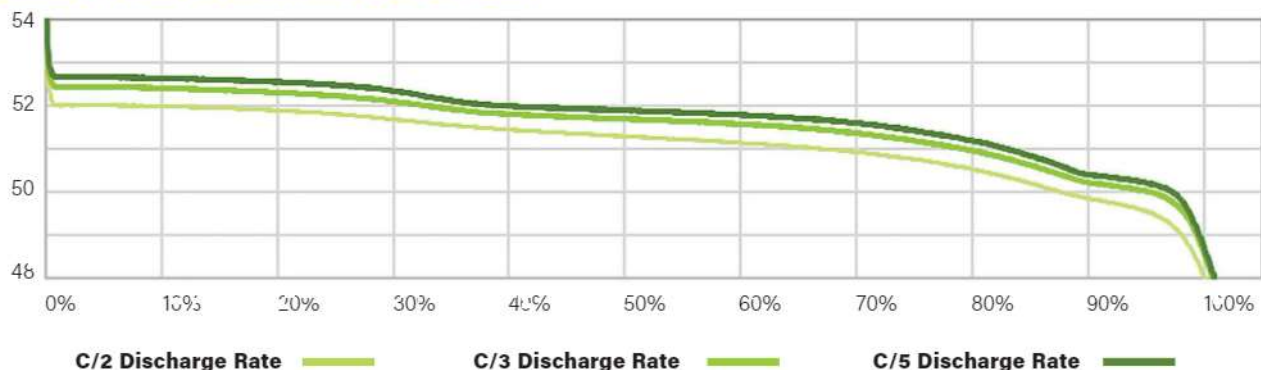

3.8

kWh

PHI 3.8-M™ Battery



BRIGGS & STRATTON

Specifications		
Model Number	PHI-3.8-24-M	PHI-3.8-48-M
DC Voltage - Nominal	25.6 VDC	51.2 VDC
Amp-Hours	151 Ah	75 Ah
Rated kWh Capacity	3.87 kWh DC @ 100% DOD 3.10 kWh DC @ 80% DOD	
Max. Discharge Rate (10 minutes)	80 Amps DC (2.05 kW DC)	80 Amps DC (4.1 kW DC)
Max. Continuous Discharge Rate	75 Amps DC (1.9 kW DC)	37.5 Amps DC (1.9 kW DC)
Max. Continuous Charge Rate	75 Amps DC (1.9 kW DC)	37.5 Amps DC (1.9 kW DC)
Certifications	UN 3480, Lithium ion batteries, 9, if UL, CE, UN/DOT and IEC compliant components - UL 1973, UL 1642	
DC Voltage Range¹	24 VDC to 28 VDC	48 VDC to 56 VDC
Depth of Discharge¹	Up to 100%	
Charging Temperature¹	32° to 120° F (0° to 49° C)	

Specifications	
Operating Temperature¹	-4° to 140° F (-20° to 60° C)
Storage Temperature	6 months: 14° to 77° F (-10° to 25° C) 3 months: -4° to 113° F (-20° to 45° C)
Self-discharge rate	< 1% per month
Cycle Life	10,000+ cycles (@ 80% DOD)
RTE Efficiency	96%
Warranty	10 years
Terminals	3/8 IN (10 mm)
Battery Cable	6 AWG MINIMUM

Product Dimensions	
Weight	86 lbs. (39.0 kg)
Dimensions (W x H x D)	13.5 x 14 x 8 in. (15.5" H w/terminals) / 0.88 ft ³ (34.3 x 35.6 x 20.3 cm / 0.025 m ³)

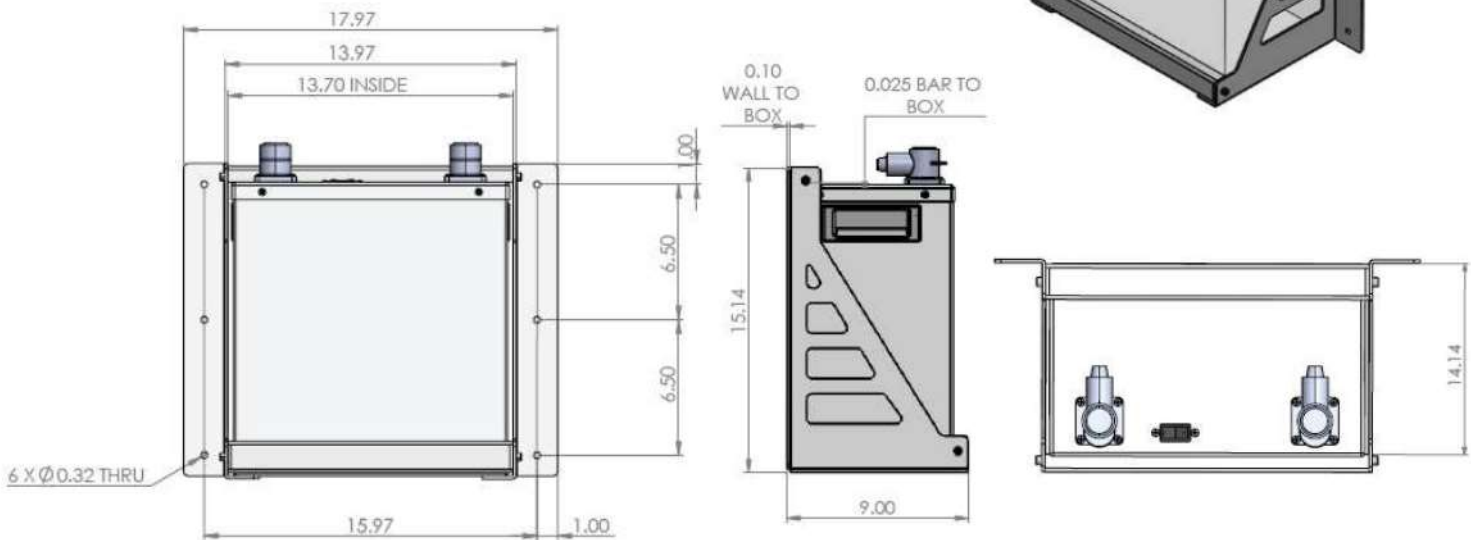
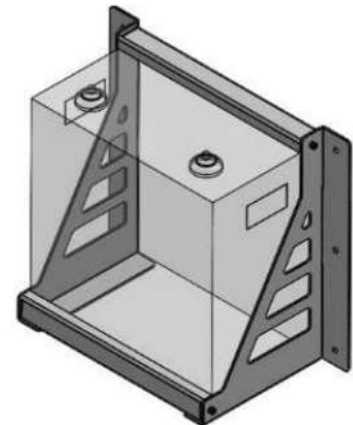

¹ Max operating ranges. Refer to installation manual for recommended conditions. All specifications listed are typical/nominal and subject to change without notice. Engineered and manufactured in California, USA

Briggs & Stratton has a policy of continuous product improvement and reserves the right to modify its specifications at any time and without prior notice. Please visit BriggsandStratton.com for the latest information. BS-397-8/22

BRIGGS & STRATTON
POST OFFICE BOX 702
MILWAUKEE, WI 53201 USA