

- NOTES  
 1. MATERIAL: 110 COPPER ALLOY, 1/8-1/2 HAVE HARD  
 2. FINISH: BRIGHT TIN PLATE  
 3. PROCESS: SHEET METAL FABRIATION AND BRIGHT TIN PLATE  
 4. CURRENT: .187"X 5.4"=1.010", EQUATES TO 1010 AMPS.

REVISION HISTORY			
REV.	DESCRIPTION OF CHANGE	DATE	SIGN
A	DESIGN RELEASE	9/21/12	RAQ
B	MOVED 4 STUDS FOR EASE OF ASSEMBLY, WAS .700", IS .220" ADDED 3 .201" HOLES FOR BUSBAR	11/2/12	RAQ

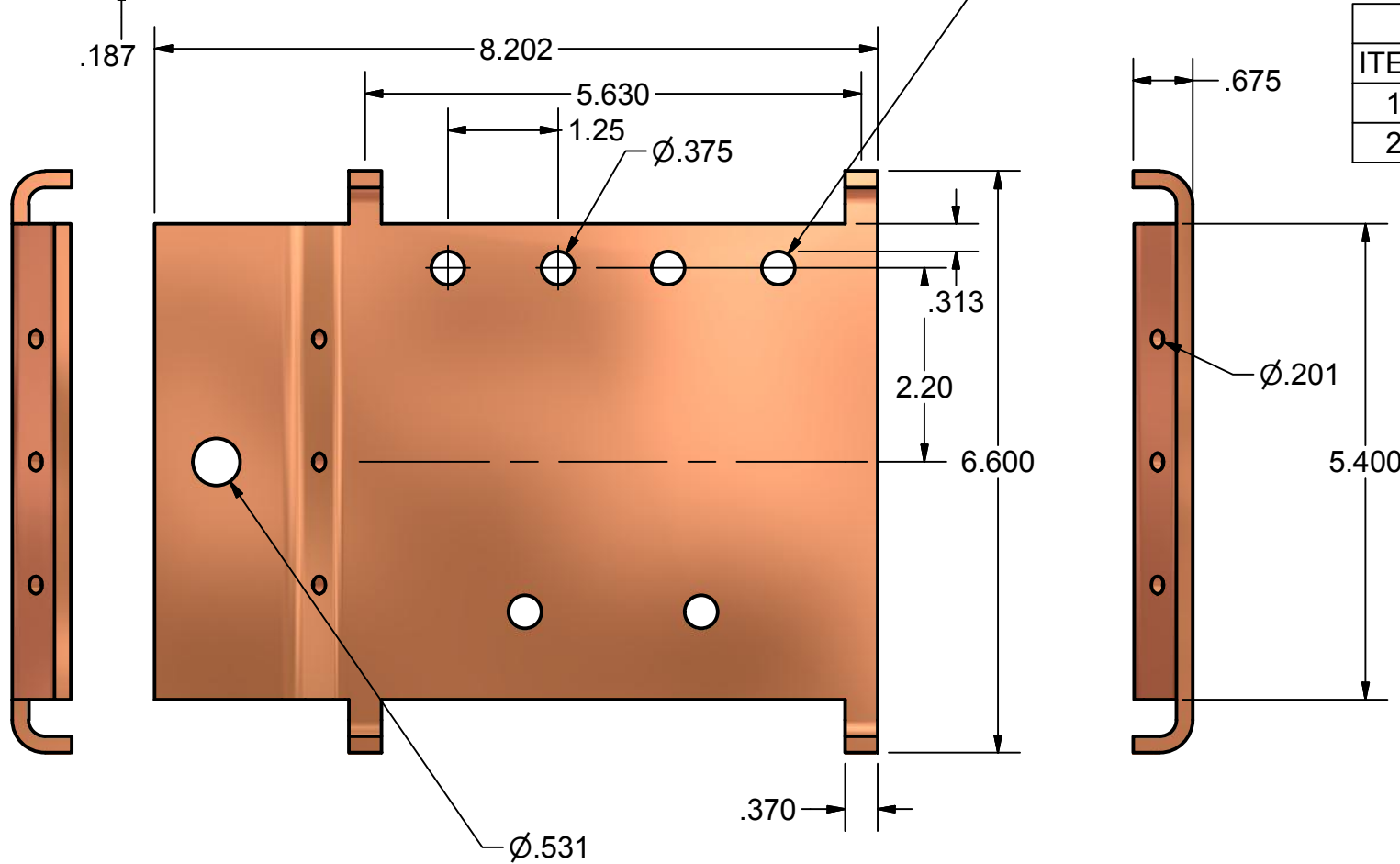

PARTS LIST			
ITEM	QTY	PART NUMBER	DESCRIPTION
1	1	3-411-1	REV B MNSMA BATTERY BUSBAR
2	6	CAPTIVE FASTENER 616-12 STUD	CAPTIVE FASTENER 616-12 STUD

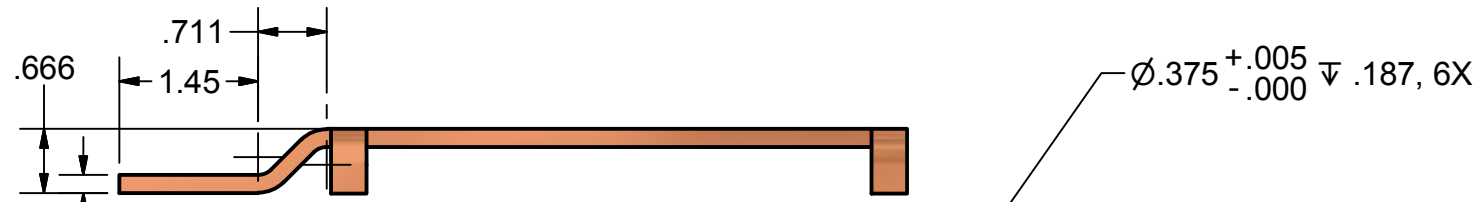
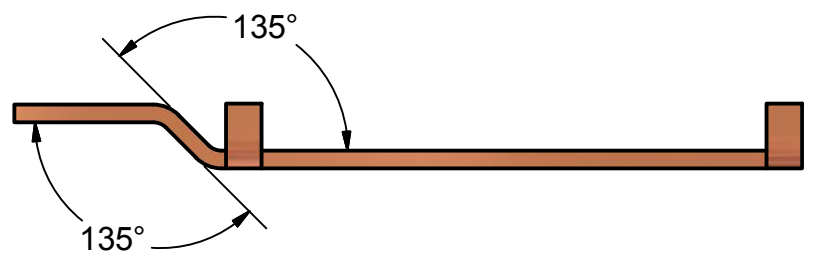
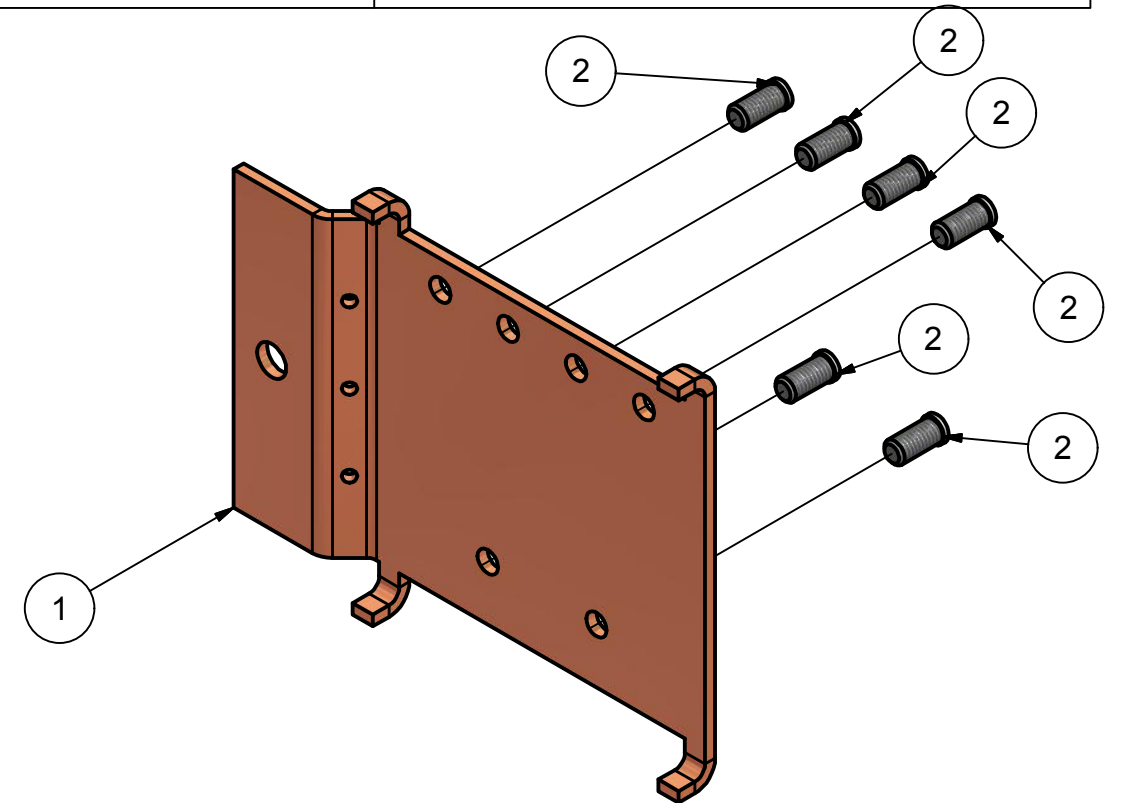

<b>ALL TOLERANCES, UNLESS OTHERWISE STATED:</b> x.xxx=+/-0.005" x.xx=+/-0.01" x.x=+/-0.05"		DRAWN Bob Q	11/2/2012
ALL ANGLES = +/- 1° UNLESS OTHERWISE STATED		CHECKED	
MATERIAL:	STANDARDS:	QA	
FINISH:		MFG	
PROCESS:		APPROVED	

**MIDNITE SOLAR, INC** 

**3-411-10 REV B MNSMA BATTERY BUSBAR**

SIZE B	PROJECT: SMA	DWG NO 3-411-10	REV B
-----------	-----------------	--------------------	----------

E-FILE:3-411-1 REV B MNSMA BATTERY BUSBAR.ipt SHEET 1 OF 2

