



E-Panel Instructions

Model: MNE125ST, MNE175ST, MNE250ST, MNE125AL, MNE175AL, MNE250AL,
 MNE175STS, MNE250STS, MNE125LT, MNE175LT, MNE250LT, MNE125ALT, MNE175ALT, MNE250ALT,
 MNE125AL PLUS, MNE175AL PLUS, MNE250 PLUS
 MNE125STM, MNE175STM, MNE250STM, MNE125ALM, MNE175ALM, MNE250ALM, MNE125STMM,
 MNE175SM, MNE250SM
 Left and Right hand 120/240VAC versions



OutBack E-Panel as installed (narrow)

Regular (narrow) OutBack E-Panel parts



Left Hand Magnum as installed

Right Hand Magnum E-Panel parts

Model Number code:

MNE-----175-----ST or AL-----M-240

MidNite E-Panel inverter breaker steel or aluminum M=Magnum inverter, blank=OutBack ,S=stretched OB, LT=Lite, -240=240VAC, blank=120VAC

IMPORTANT SAFETY INSTRUCTIONS

SAVE THESE INSTRUCTIONS - These instructions contain important safety and operating instructions for MidNite Solar E-Panels.

If you do not fully understand any of the concepts, terminology, or hazards outlined in these instructions, please refer installation to a qualified dealer, electrician or installer. These instructions are not meant to be a complete explanation of a renewable energy system.

GENERAL PRECAUTIONS

WORKING WITH OR IN THE VICINITY OF A LEAD ACID BATTERY, SEALED OR VENTED IS DANGEROUS. VENTED BATTERIES GENERATE EXPLOSIVE GASES DURING NORMAL OPERATION. FOR THIS REASON, IT IS VERY IMPORTANT THAT BEFORE SERVICING EQUIPMENT IN THE VICINITY OF LEAD-ACID BATTERIES YOU REVIEW AND FOLLOW THESE INSTRUCTIONS CAREFULLY.

If service or repair should become necessary, contact MidNite Solar Inc. Improper servicing may result in a risk of shock, fire or explosion. To reduce these risks, disconnect all wiring before attempting any maintenance or cleaning. Turning off the inverter will not reduce these risks. Solar modules produce power when exposed to light. When it is not possible to disconnect the power coming from the Photovoltaics by an external means such as a combiner, cover the modules with an opaque material before servicing any connected equipment.

Never attempt to charge a frozen battery.

When it is necessary to remove a battery, make sure that the battery bank disconnect breaker is in the off position and that the PV breakers, grid breakers and any other sources of power to the inverter are in the off position. Then remove the negative terminal from the battery first.

To reduce risk of battery explosion follow these instructions and those published by the battery manufacturer as well as the manufacturer of any additional equipment used in the vicinity of the batteries. Before installing the battery enclosure, read all instructions and cautionary markings in or on any connected electrical equipment.

Avoid producing sparks in the vicinity of the batteries when using vented batteries. Provide ventilation to clear the area of explosive gases. Sealed AGM and Gel batteries do not under normal conditions create explosive gases. Be especially cautious when using metal tools. Dropping a metal tool onto batteries can short circuit them. The resulting spark can lead to personal injury or damage to the equipment. Provide ventilation to outdoors from the battery compartment when installing vented batteries such as golf cart T-105 batteries. The addition of a spill tray is also a good idea.

Clean all battery terminals. Very high currents are drawn from the batteries; even a small amount of electrical resistance can result in overheating, poor performance, premature failure or even fire.

Have plenty of fresh water and soap nearby in case battery acid contacts skin, clothing or eyes. Wear complete eye and clothing protection. Always avoid touching eyes while working near batteries. If battery acid or battery terminal corrosion contacts skin or clothing, wash immediately with soap and water. If acid enters the eyes, immediately flood with cool running water for at least 15 minutes and get medical attention immediately. Baking soda neutralizes battery acid electrolyte. Keep a supply near the batteries.

Do not work alone. Someone should be in the range of your voice or close enough to come to your aid when you work with or near electrical equipment.

Remove rings, bracelets, necklaces, watches etc. when working with batteries, photovoltaic modules or other electrical equipment. Power from an illuminated photovoltaic array makes a very effective arc welder with dire consequences if one of the welded pieces is on your person.

To reduce the risk of injury, connect only deep cycle lead acid type rechargeable batteries. Other types of batteries may leak or burst, causing personal injury or damage.

This equipment is NOT intended for use with life support equipment or other medical equipment or devices.

It is the responsibility of the installer to verify compliance with all applicable codes.

Before making any connections verify that the circuit breakers are in the off position including the inverter breaker. Double check all wiring before applying power.

E-Panel Instructions (continued)



Stretched OB with OB surge arrestor
Gray steel right or left available



Stretched OB parts as shipped



E-Panel LT, gray steel version
White aluminum also available



E-Panel LT parts as shipped

E-Panel Instructions (continued)



E-PANEL PLUS AS INSTALLED
White aluminum left hand only



E-PANEL WIRED
With MNSPD Surge Protector
Devices & charge control breakers



E-PANEL FOR MAGNUM **MM** SERIES
AS INSTALLED

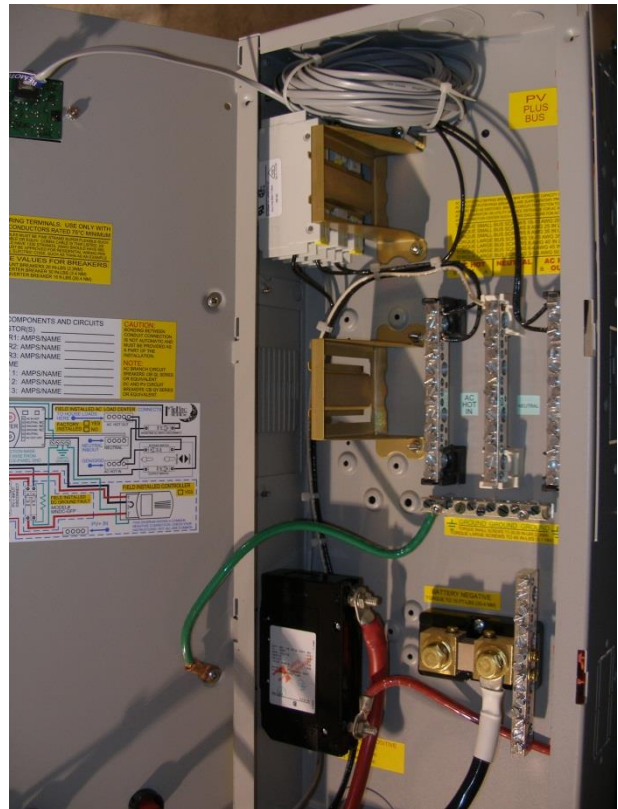

MM SERIES E-PANEL WIRED

E-Panel Instructions (continued)



SamlexEVO version as installed with optional equipment.



Magnum-AE version 120/240VAC These models have their own separate installation manual



This shows the parts that come with the 120/240VAC E-Panels

E-Panel Instructions (continued)

The MidNite Solar E-Panel comes standard with the basic over-current protection and disconnects required to install your renewable energy system. It can also expand to grow as your needs arise.

List of features:

- Steel or aluminum chassis with all the required openings and knock outs to aid in a NEC compliant system installation
- Inverter mounts on a unique hinged door to keep the footprint of the system small as possible
- Mounting brackets are included to aid in one person installations
- Inverter battery breaker, inverter cables and snap in grommets included*
- 500 amp / 50mv shunt included for battery monitoring systems
- Bus bars are included for additional battery plus, PV plus and battery minus wiring
- Heavy duty 175 amp AC power distribution bus bars included
- 50 amp AC input disconnect for generator or utility included, pre-wired (15amp MM series)
- 50 amp AC bypass switch for bypassing inverter circuit, pre-wired (15amp MM series)
- Mounting bracket to aid in mounting an OutBack MX60 or MidNite Classic to the side of the E-Panel*
- Battery cable cover to enclose cables external to the chassis***
- Inverter and charge controller mounting hardware
- Rectangular cut outs for mounting a North American GFCI style AC outlet
- Cut outs for mounting up to six additional 13mm wide din rail mount breakers and three ¾" wide panel mount breakers for additional circuits such as PV, wind, hydro or AC distribution
- Plastic snap in conduit and fittings from chassis to inverter for AC, BTS and control circuits (OB versions)
- ETL listed to UL and CSA standards

* inverter cables and charge control bracket omitted on the LT configurations

*** LT versions do not have a cable cover, MM series uses the inverter battery terminal caps

E-Panel Instructions (continued)

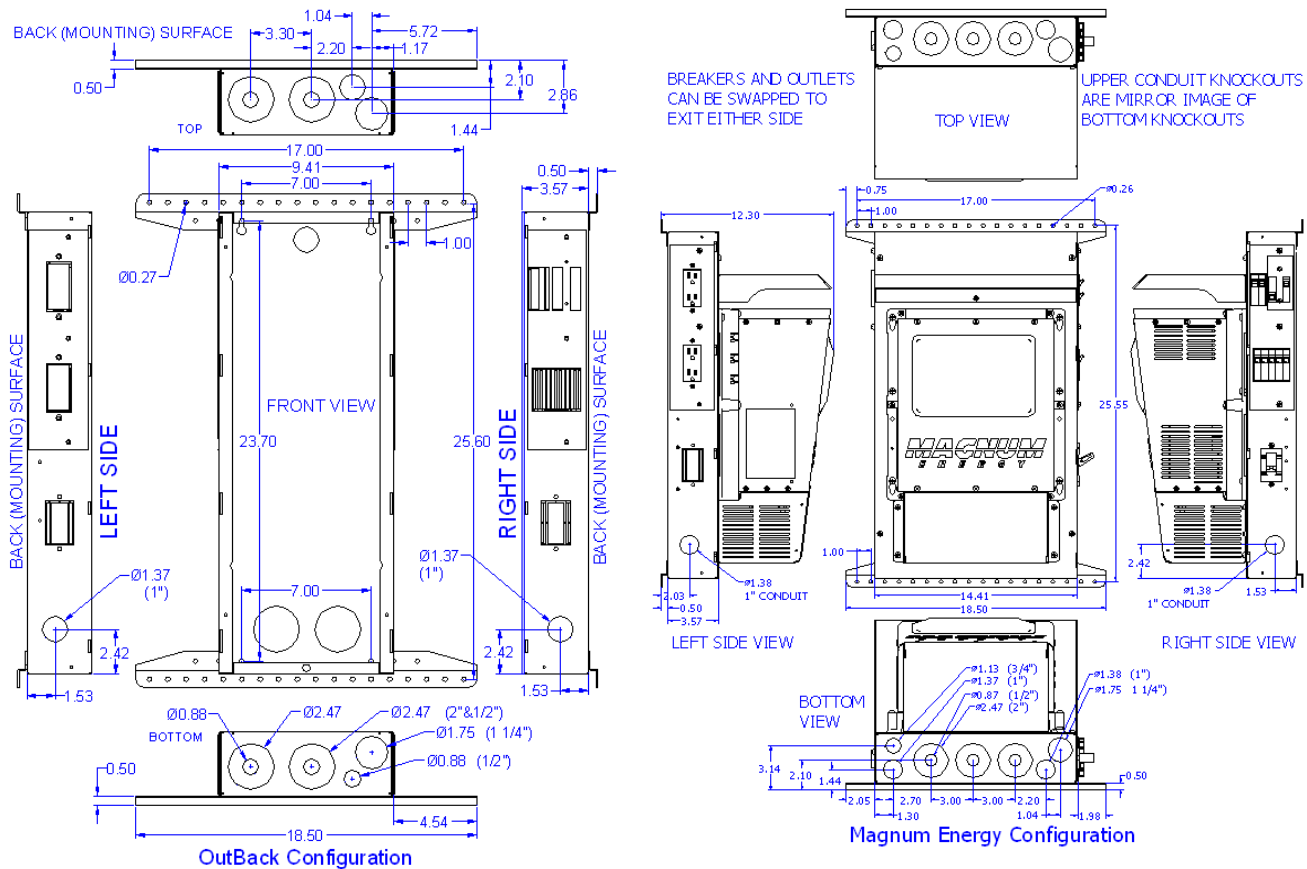

Note: The Stretched OutBack E-Panel uses the 14.41" Magnum chassis. The LT and MM version use the 9.41" OB sized chassis.

The dimensioned chassis drawings above show the location of the conduit knockouts, mounting holes and mounting brackets.

- ✓ Knockouts on the top surface are directly in line with ones on the bottom surface for stacking units vertically.
- ✓ Knockouts on the lower end of each side are directly in line with each other for stacking horizontally.
- ✓ Steel powder coated units are gray textured. Aluminum powder coated units are gloss white.

Door Configuration

The standard E-Panel comes as a left hand hinged assembly with breakers on the left side and a left hand hinged door. The door will open to the left over the breakers. If for some reason you need the breakers on the left, but the door to open to the right, then you need the optional right hand door. All breakers can be unmounted and reassembled on the right side of the chassis as is explained in this manual. Right hand E-Panels can be built special at the factory for no additional charge. Changing sides in the field is not a simple task! The left hand hinge is standard because the majority of charge controllers need to be mounted to the right side of the E-Panel. See below.

1. Apollo T-80 should be a left hand hinge (heatsink is on the right)
2. MidNite Solar Classic should be a left hand hinge (heatsink is on the right)

E-Panel Instructions (continued)

3. OutBack MF80 should be left hand hinge (No knock out on the right side of chassis)
4. MX60 works equally as well on either side
5. WX controller works equally as well on either side
- 6 C40/C60 and Tri-star work equally as well on either side
7. **Blue Sky has the heatsink on the left, so should use a right hand hinge.**

See E-Panels explained on the MidNite website www.midnitesolar.com for exact part numbers of door options and an explanation of each E-Panel platform. E-Panels Explained will further help you in selecting the applicable E-Panel for your application.

The installation begins by selecting a wall. All E-Panels are indoor rated and should not be placed outside unless precautions are made to keep rain and moisture off of the system. The wall must have suitable clearance to open the door with inverter attached. It must also have adequate clearance to operate the breakers and outlets that protrude out the sides. The NEC requires 30" clear on the wall. The E-Panel may be located anywhere within this 30 inches, however make sure you have sufficient room to the side to operate the circuit breakers. Some E-Panel installations may have circuit breakers on both sides. The NEC also requires 36 inches free and clear of obstructions in front of the E-Panel. The 36" clear area in front of all electrical panels is to provide a space to fall back into incase of electrical shock. Each E-Panel with its' inverter will weigh close to 100 pounds so make sure your wall is adequate for this load. The mounting brackets provided will span studs on 16 inch centers. Mount the top bracket as shown at about 64-68 inches off the floor. If stacking two systems vertically, make sure the breakers fall within the NEC guidelines for height, (lowest and highest allowable). Number 10 screws with back up washers will suffice, but ¼" (6mm) hardware provides for a better margin of safety.



A little pre-planning here will go a long way towards a successful installation. Battery box placement and size also need to be thought out for NEC compliance. The remote display should be approximately at eye level when attached to the E-Panel. Some installation photos below show various ways to install your system.



A Positive Energy installation, NM
Outdoors in an enclosure



A Jay Peltz installation, CA
In the basement



A Lance Barker
installation, OR
In the house

E-Panel Instructions (continued)

You can make life a little easier by installing additional breakers for charge control, the inverter and such while the E-Panel is still lying horizontal on a table. Do as much of the additional wiring as possible before hanging the E-Panel on the wall. The following pictures show some of the operations that can be done “on the bench” where access is optimal.



Be careful not to dislodge larger knockouts on concentric knockouts



Pre-tap inverter mounting holes using a #3 Philips screwdriver and thread forming



Attach inverter to door, but don't hang it on the chassis until all other wiring is done

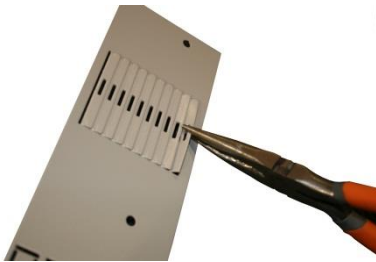

Break off circuit breaker tabs. Two per breaker



Check fit for any burrs



Attach bottom mounting bracket

Field installed breakers should be torqued to 20 inch pounds, then **re-torqued** after one hour. This is important! Wires cold flow and sometimes loosen up after the initial tightening, so don't skip this step. E-Bay is a good source for Sturdevant Richmond torque screw drivers if you are an installer.

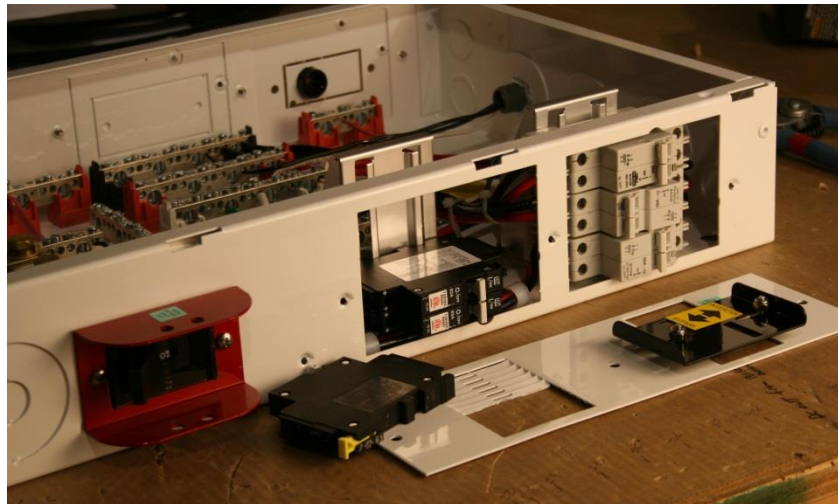

E-Panel Instructions (continued)

Breakers such as charge control input and output and DC-GFP can be completely wired prior to installation on the wall. Field wiring is done at the PV, AC and DC terminal bus bars.



This picture shows the Outback E-Panel mounted with two MNEPV63 charge control breakers installed and an AC and DC MNSPD Surge Protector Device. The upper mounting bracket can be secured to the wall and then the E-Panel chassis hung onto it using the keyhole slots in the upper back of the chassis.

Before mounting the inverter to the chassis and with the E-Panel mounted on the wall, complete all wiring that will be coming to and going from the E-Panel. The following pictures give you some idea of what to expect.

The picture to the right is a Magnum 240V E-Panel. Notice it has an OutBack OBDC-GFP mounted on the left side of this right hand hinge unit. There are a total of six din rail slots available on each E-Panel for customer configuration. This installation has two charge controllers. You need a breaker in the PV input and on the DC output of the charge controller. This took up **4 din rail slots** for this system. The MidNite DC-GFP takes up **2 din rail slots** for the 63 amp version and **2 panel mount knock out slots** for the 80 amp version. Neither one of these would work in this case, so the two circuit OutBack GFP was used. It takes up three slots on the blank plate opposite the din rails. Note the green 6AWG neutral to ground bonding wire in this picture. The neutral to ground bond is required on all systems per NEC. Note that if this were a power back up system on a utility connected home, this bonding wire would not be installed as it would already be there on the service entrance. On off-grid installations that



E-Panel Instructions (continued)

employ a sub panel circuit breaker box, you can make this neutral to ground bond in the sub-panel. It is technically better to make this bond closest to the source of power (the E-Panel), but many electrical inspectors will be looking for it in the sub-panel box. It will work just fine in either location, just make sure you have adequate conductor sizes between the E-Panel and the sub-panel. Do not rely on the hinges for grounding the equipment mounted to the door.



The picture to the left shows the charge control bracket supplied in the E-Panel kit. This one is for a left hand hinged unit, so the charge control bracket is on the right side opposite the din rail breakers.

The charge control bracket supplied works with the OutBack MX60, MF80, MidNite Classic and Xantrex WX charge controllers. The Charge control bracket is secured to the E-Panel with 3 #10 x 3/8" sheet metal screws. Use one more screw to secure the top bracket of charge controller and a 1" close nipple on the side as shown below. Note that it takes three 1" locknuts to mount the

controller. One lock nut is used in between the E-Panel side and the charge controller side to act as a spacer. It may help to replace the pan head screws on the side plate with flat head screws in some cases to increase clearance.



In addition to the 1" close nipple and three locknuts, you will need plastic threaded adapters installed on the ends of the metal threaded nipple. These adapters protect wires from coming into contact with the sharp edges of the metal close nipple.

Before wiring the charge controller, determine what size wire and breakers

will be required. The breakers are there to protect the wiring, not the controller!

It is very common to use the MidNite 63 amp din rail breakers for this task. Even if the charge controller is only 30 amps, it can be wired using 63 amp breakers. You will need 6AWG wire to go with those breakers though. If using one of the more powerful 80 amp charge controllers, you will need the MNEDC80 panel mount breakers. These mount on the opposite wall from the din rail breakers. 4AWG wire is required to match up with these 80 amp breakers.

The flow path for the PV circuit is as follows:

1. The PV + wire comes into the E-Panel and attaches to the PV+ busbar
2. The PV- comes into the E-Panel and attaches to the shunt busbar. This is for charge controllers that have a common PV- and battery- connection, (most are this way). Some charge controllers like the Xantrex XW and the Blue Sky must keep the PV- and battery- circuits separated. The E-Panels have mounting embosses to accommodate a short white busbar to act as an isolated PV-. Use the MNSBBW for the busbar.
3. From the PV+ busbar, use the appropriate gauge red wire (THHN) and connect to the PV+ IN breaker. DC breakers have polarity markings. These may be a + sign or a line and load sign. Although the PV circuit has very limited energy available and thus making polarity issues not too critical, it is best to try to get it right. This is where the fun begins.

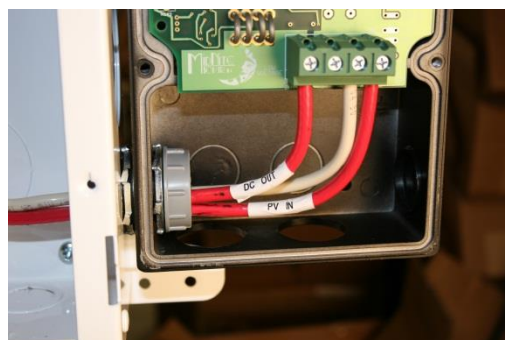

E-Panel Instructions (continued)

4. The + (line) marking on the breaker would seem to indicate that you should connect the PV+ to this terminal since the PV+ is the highest potential in the system. Our testing shows this would be correct. The + side of the breaker needs to be connected to the highest potential per the breaker instructions.
5. The - side of the PV in breaker goes to the charge controller PV+ input terminal.
6. The output of the charge controller is sometimes marked battery+ This terminal is to connect to the charge controller output breaker. It will **not** connect to the + or Line side of the breaker.
7. The other side of the breaker, + or line connects to the battery plus busbar. This connection is important to observe polarity markings. In the event of a charge controller failure, they quite often short internally, which means they are shorting out the battery. If proper polarity is not observed, the breaker may not open and the wiring will burn up.

The factory installed red battery plus bus wire is 4AWG, so it is large enough for all breaker sizes.

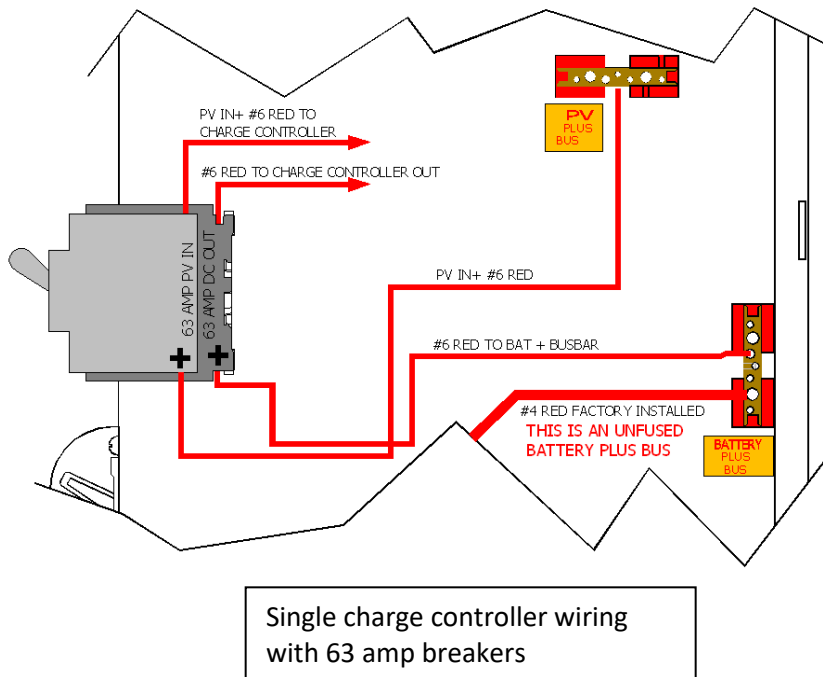

The diagrams above show 63 amp din rail mount breakers. When 80 amp breakers and or DC-GFP are required, those breakers mount on the wall opposite the din rails. There are three panel mount breaker slots to accommodate the 80 amp breakers and DC-GFP. The 80 amp DC-GFP takes up two of the three slots. The third slot will be used for the output of the 80 amp charge controller. The PV input to an 80 amp charge controller could use a 63 amp din rail mount breaker. There is no additional DC-GFP required when using the MidNite Classic controller. The DC-GFP and arc fault protector are built into the Classic controllers.

E-Panel Instructions (continued)

Mounting the inverter

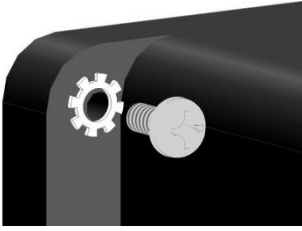

The 6 x 20mm pan head Philips screws for mounting the inverter are taptite (thread forming). Use one of these 6mm screws to pre-tap threads into the steel doors extruded funnel holes. Aluminum doors have press nuts and do not require tapping. Make sure to install all 1/4" star washers to bite through the powder coating.



One of the best features of the MidNite E-Panel is that one person can do all the lifting.

Slip Tab A into Slot B Install inverter cables

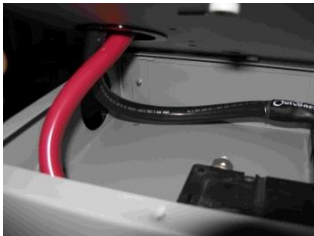

Install the 3.5" bushing as shown protruding up into the inverter side of the door before routing the inverter cables through the door.

3.5" grommet protruding outward

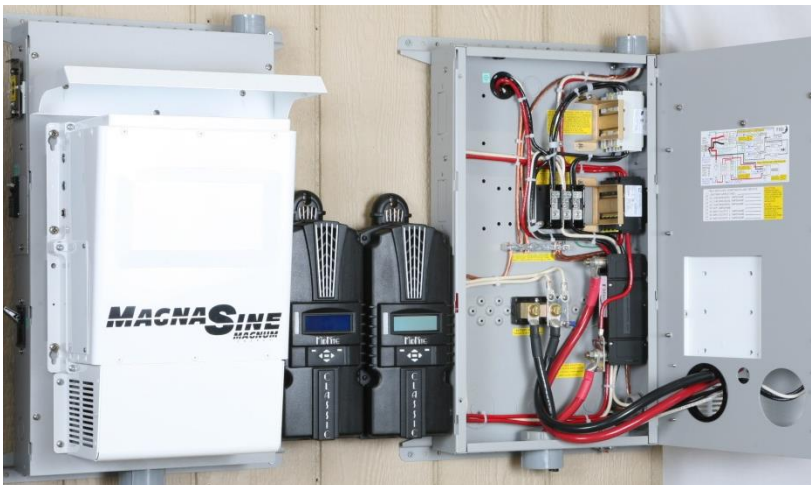
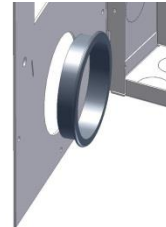

The left Magnum inverter is all wired and the DC cover installed using four 10-32 x 7/16" taptite screws and #10 internal tooth star washers. The upper shield is installed using three 10-32 x 3/8" machine screws and kepnuts. Use small snap in grommets for signal level cables.

E-Panel Instructions (continued)

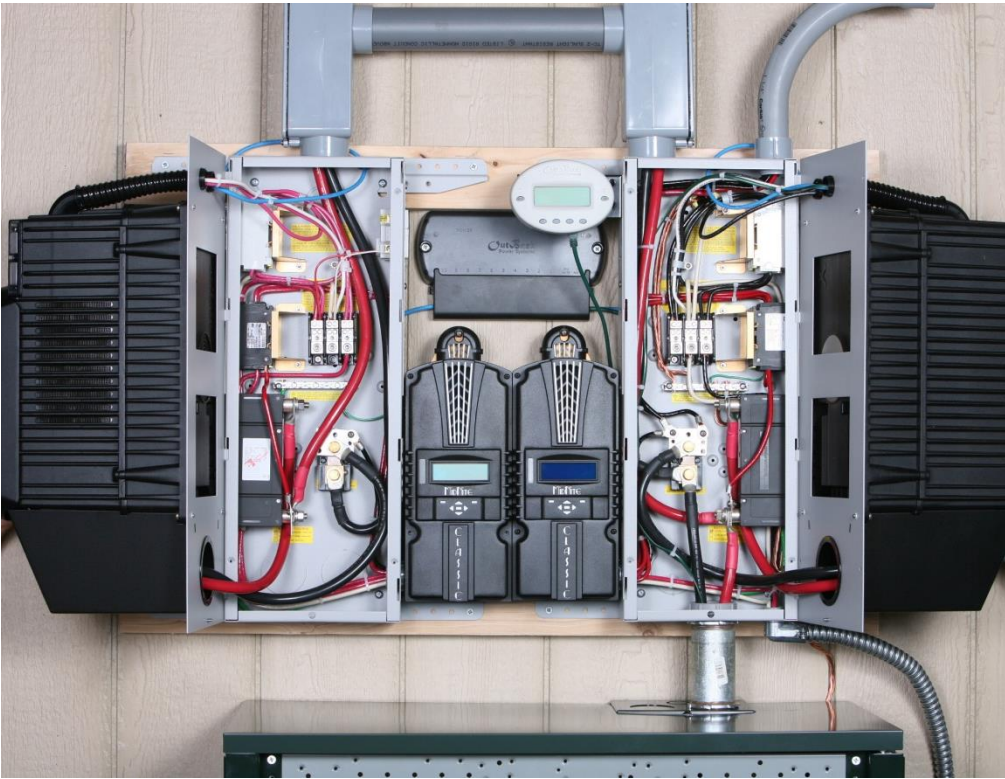

Doors installed, plastic conduit installed, wiring complete. Note the battery cable routing. It is important to route cables so the doors close freely without undue force. The left E-Panel battery cables came from above, but could have

More tidbits to digest

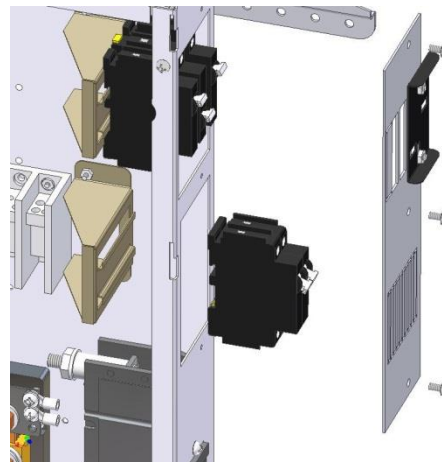
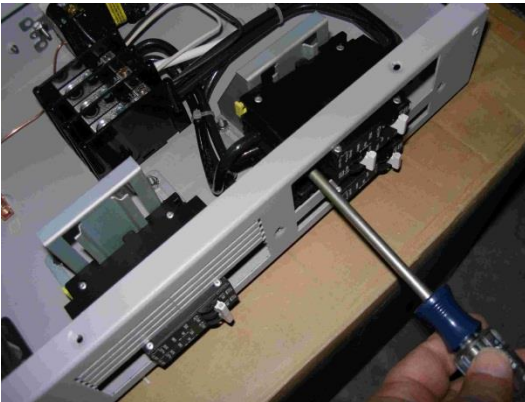

Important! Torque din rail mount breakers to 20 in lb. **Wait one hour and re-torque.**

Installing the breaker cover

Six locations are available for additional 13mm wide breakers. These breakers would normally be field installed for such things as: solar, wind or hydro charge controllers, DC ground fault protector, AC and or DC distribution center and others. Remove the cut outs for the intended breakers. Each 13mm wide breaker requires removal of two cut outs. 17.5mm wide breakers require removal of three cut outs. It is important to torque the terminals to 20 inch pounds. It is highly recommended to go back over all terminations after an hour and also conduct a pull test.

E-Panel Instructions (continued)

You may be surprised that what you thought was a tight connection actually pulls out with little effort. This is caused by a phenomenon called cold flow. Copper is a relatively soft metal and will continue to move under inadequate clamping pressure. A 20 inch pound of torque takes a lot of strength! Use the supplied UL listed plastic 2" x 6" spacers to separate AC and DC breakers if installed on the same din rail. Barriers are required per NEC between AC and DC circuits.

MidNite offers 150VDC breakers in 1,2,3,4,5,6,7,8,9,10,12,15,20,30,40,50 and 63 amps. AC breakers are available in 10,15 and 20 amp sizes. Those breakers carry the UL489 and UL489A branch circuit rating. 30 and 50 amp AC breakers are available in UL1077 listed versions, but are not branch circuit rated.

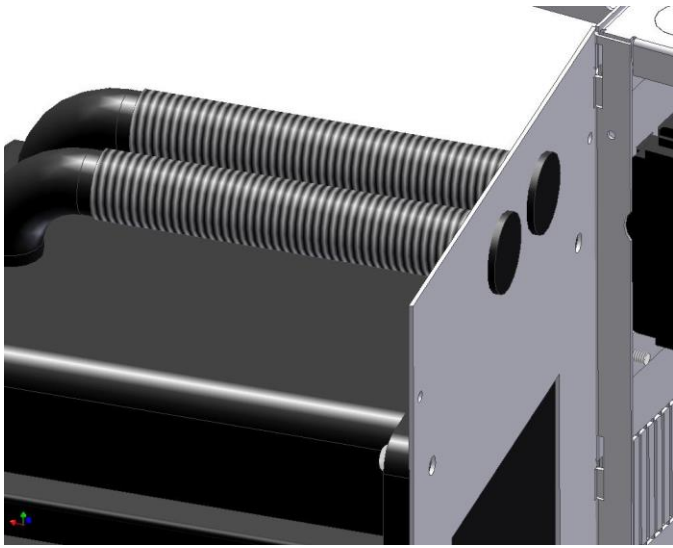

For OutBack installations, install the conduit pieces supplied by routing the three wires through the door and conduit before snapping the fittings into place. Snap the top right angle fitting into place first and then the one in the door. Once the length of wire has been established by opening and closing the door, then cut back the three wires as required and hook up to the terminal block. The conduit in the middle of the inverter is for AC wiring. The outer conduit is for remote and battery temp sense wires.

Note: Battery cables in a NEC compliant system requires cable listed for use in residential wiring.

Plastic flex conduit with snap in fittings

For installations requiring the OutBack surge arrester, see pictures below. Note that this surge arrester is only accommodated on the Stretched OutBack E-Panel.



The flex conduit snaps into the sides of the surge arrester. You will need to get an adapter to go from the 1" conduit hole in the surge arrester housing to the 3/4" flex conduit. These are readily available at your local electrical supply store or Home Depot/Lowes.

E-Panel Instructions (continued)

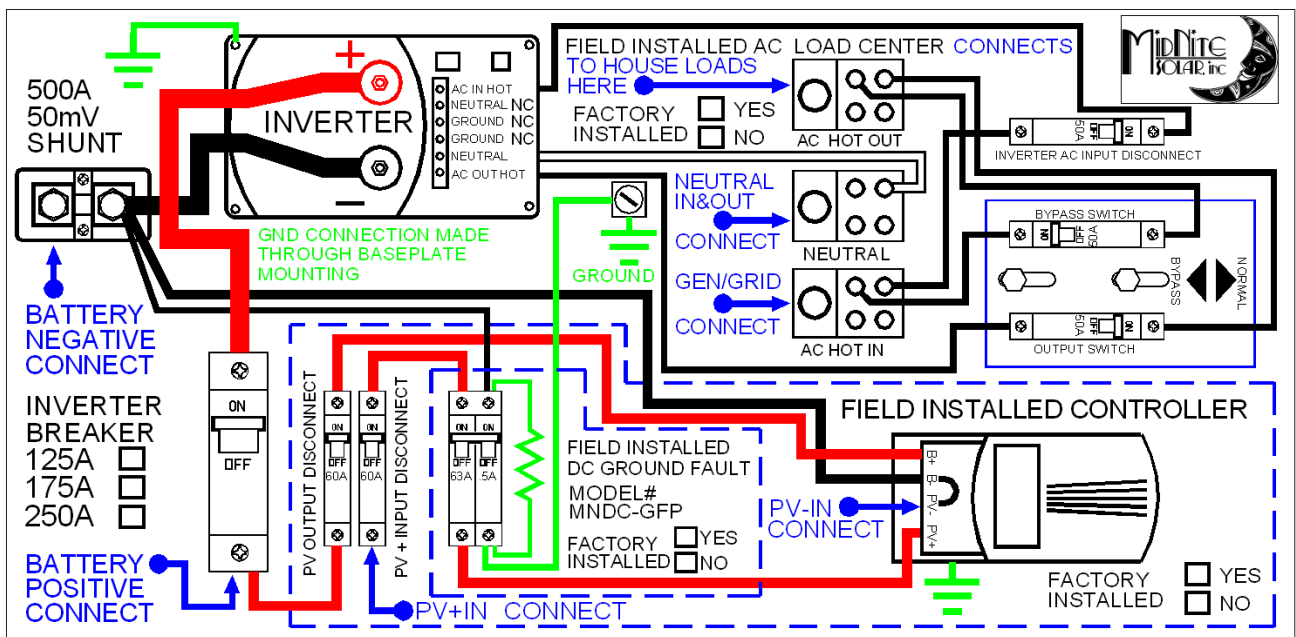

This basic wiring diagram is mounted on the inside of the hinged door. Elsewhere in these instructions is a slightly expanded version of the E-Panel wiring diagram. There is an AutoCAD version of the expanded wiring diagram at www.midnitesolar.com. This is provided so that interested parties may download and modify it to tailor their specific system configuration. When stacking two OutBack inverters, it may be required to add the OutBack PSX-240 autotransformer.



OutBack and Magnum horizontal stacked systems

E-Panel Instructions (continued)

E-Panel parts locator, Door

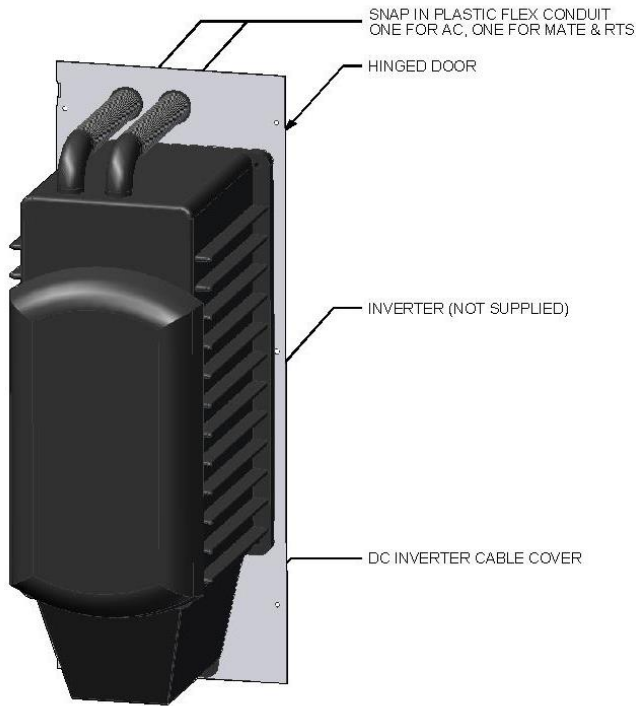

Supplied insulators to achieve required separation of AC and DC circuits

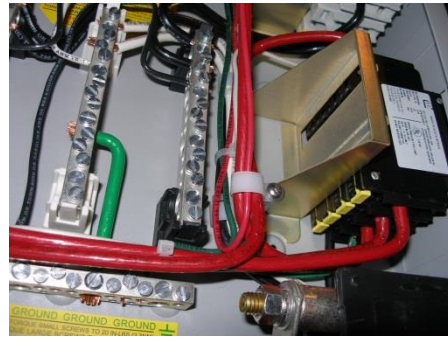

E-Panel parts locator, internal

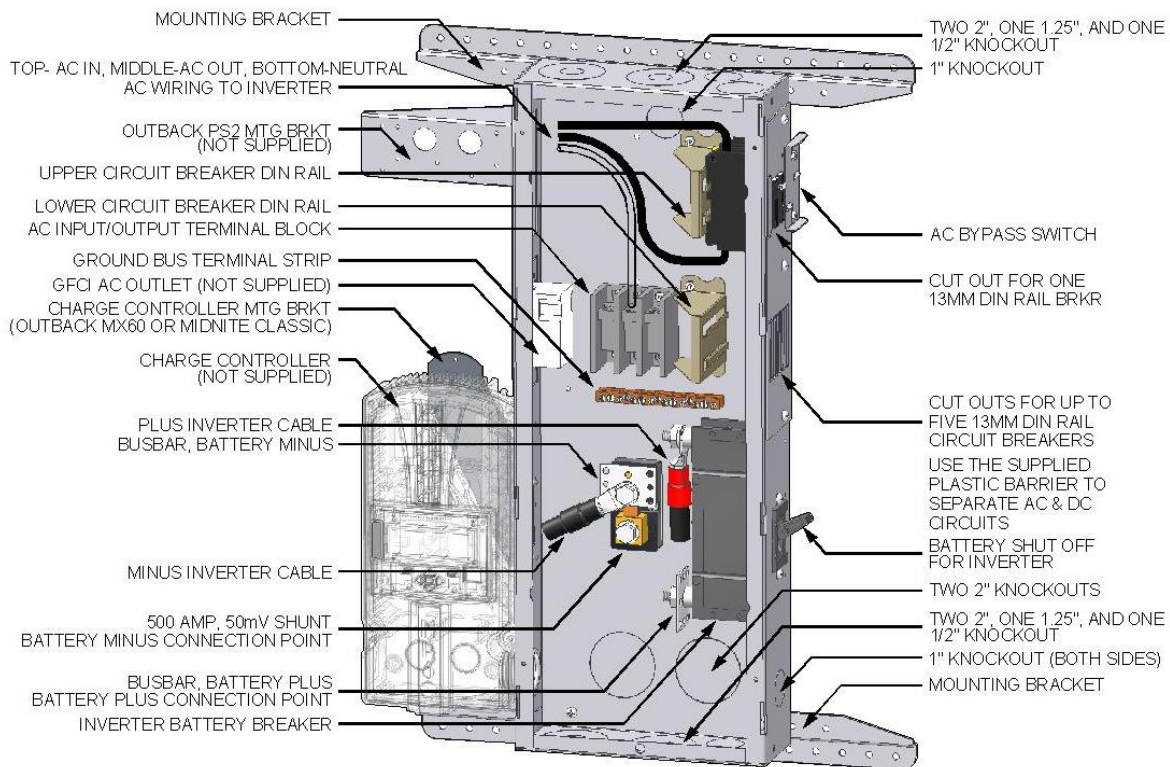

Ground to Neutral connection

E-Panel Instructions (continued)

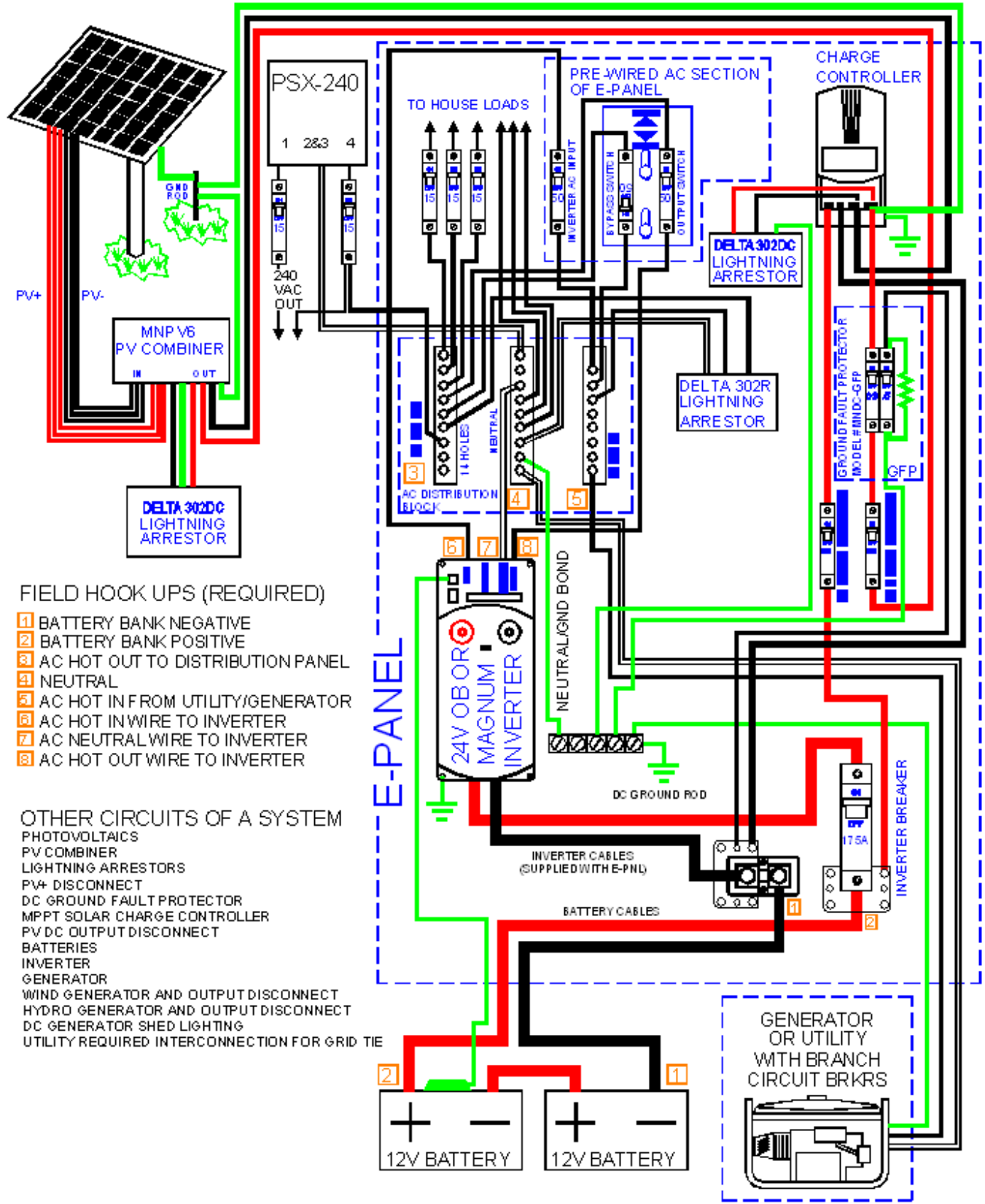

Magnum MS4448-AE & MS4024-AE system pre-wire with DC-GFP

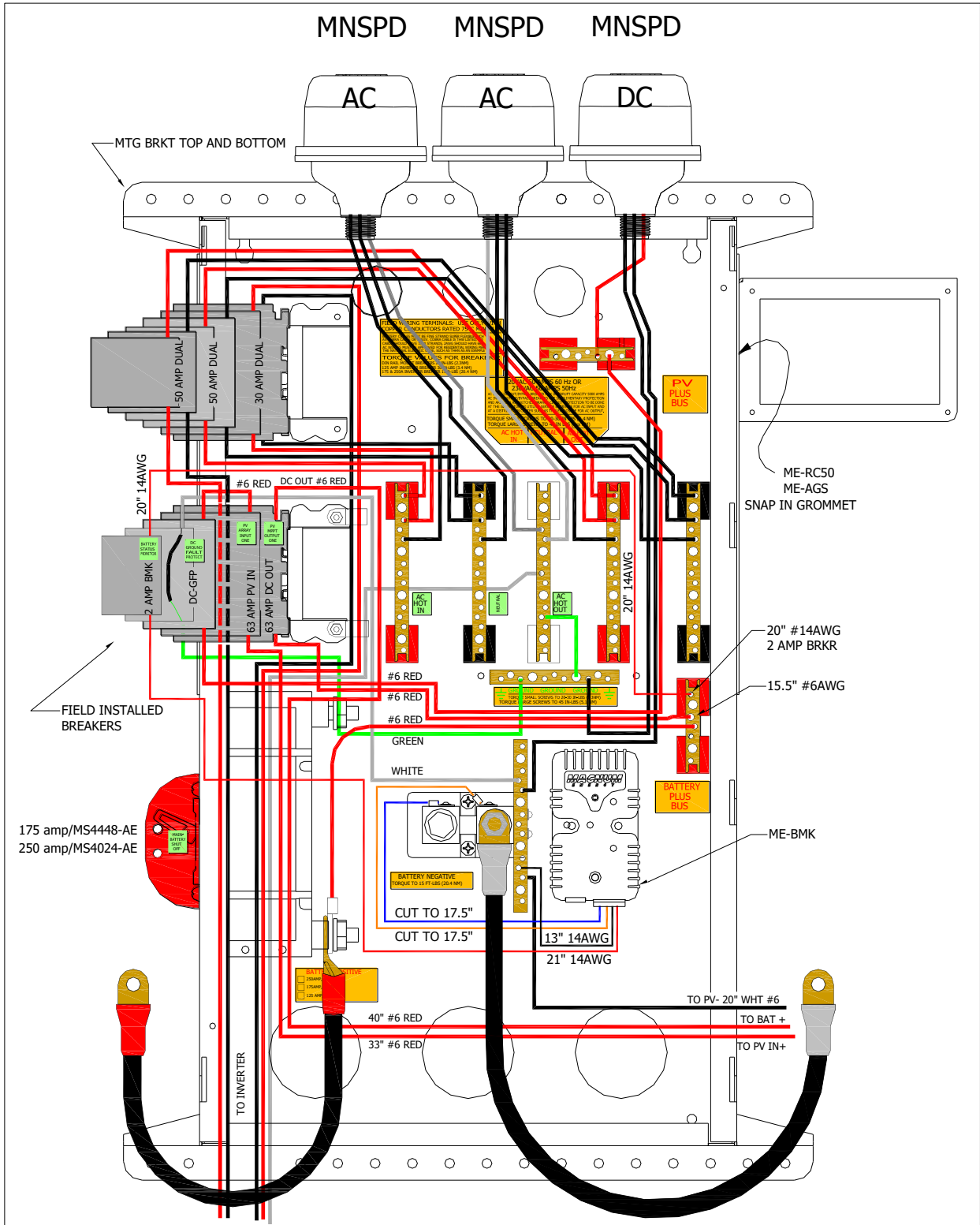

MNE175SM / MNE250SM Samlex E-Panel wiring. MNE175SM Shown.

MNE175SM SAMLEX E-PANEL REVD 3/10/16

